

TSUBAKI DRIVE CHAINS & SPROCKETS



POWER to the WORLD!

Tsubaki's pursuit of outstanding quality drives the world.

Since its founding, Tsubaki has pursued the world's most outstanding quality while contributing to a better society. And Tsubaki will continue providing the world with only the best.

Basic Environmental Policy of the Tsubaki Chain Group

Philosophy

The Tsubaki Chain Group recognizes that the protection of the global environment is one of the chief responsibilities of all mankind. It is our goal to show consideration for the environment in all of our business activities in order to contribute to a better tomorrow.

Policy

- Always be aware of the environmental effects of business activities, products and services, and strive to reduce the related environmental load from the perspective of global environmental protection.
- Streamline our organization for environmental protection and continually improve our environmental management systems.
- Comply with environmental laws, regulations and agreements.
- Help the entire workforce understand our basic environmental policy, and enhance their awareness of global environmental protection via environmental education, internal publication activities, etc.

Kyotanabe Plant Concepts

Kind consideration towards the global environment

Harmony and coexistence with the global environment

Pursuit of high efficiency and high quality

Courage to look to the future



Tsubakimoto Chain's Kyotanabe Plant is a state-of-the-art facility outfitted with the latest environmental systems to produce environment-friendly products that meet the needs of the times and our customers.

Internationally Accredited Plant

Tsubakimoto Chain aims to make products that are people-friendly, environmentally friendly, and reliable. Tsubakimoto Chain acquired ISO9001 accreditation in 1995 and ISO14001 accreditation in 2003.



JQA-0911
Chain Division
JQA-QMS640
Environmental
Management
Department



JQA-EM3392
Kyotanabe Plant



Trust Tsubaki's Robust Line-up to Increase Your Productivity

Index



New Products Pg. 5

Before Use Pg. 7

- Notes on Using Roller ChainPg. 7
- General Comparison of Transmission Elements.....Pg. 8
- Features and Precautions of Roller Chain TransmissionPg. 8

Glossary Pg. 9

Roller Chain Construction Pg. 11

Roller Chain Product Line-up Pg. 13

Ordering RS Roller Chain Pg. 15

Roller Chain Selection Pg. 162

1. Selection Guide Pg. 163
2. Service Factors Pg. 165
3. Provisional Selection Graph Pg. 166
4. Selection Formulae Pg. 168
5. General Selection Pg. 171
6. Allowable Load Selection Pg. 173
7. Example of Lifting Transmissions Pg. 178
8. Calculating Moment of Inertia Pg. 180
9. Example of Shuttle Traction Pg. 181
10. Pin Gear Drive Selection..... Pg. 182
11. Temperature Selection Pg. 188
12. Special Selection Method for Corrosion Resistant Roller Chain ... Pg. 188
13. Corrosion Resistance Reference Guide for Corrosion Resistant Drive Chains and SprocketsPg. 189

Handling Roller Chains and Sprockets Pg. 190

1. How to Cut Roller Chain Pg. 190
2. How to Connect Roller Chain Pg. 191
3. Roller Chain Lubrication Pg. 192
4. Layout and Installation Pg. 194
5. Sprockets Pg. 196
6. Chain Test Run Pg. 197
7. Roller Chain Inspection..... Pg. 197
8. Cautions on Use in Special Environments ... Pg. 201
9. Troubleshooting Pg. 202

Roller Chain Inquiry Sheet Pg. 206



Eco Link Mark

These products meet Tsubaki's voluntary eco assessment criteria.

Standard Roller Chain Pg. 18



RS Roller Chains feature even higher kilowatt ratings and better performance for each size.

- RS® Roller ChainPg. 18
- BS/DIN Standard RS Roller ChainPg. 49

Lube Free Roller Chains Pg. 53



Reduce your maintenance times, improve your work environment, and increase your productivity.

- Lambda ChainPg. 57
- Lambda Chain NP Series ...Pg. 58
- X-Lambda ChainPg. 59
- Lambda Chain KF Series ...Pg. 60
- Heavy Duty Lambda Chain ...Pg. 63
- Curved Lambda Chain ...Pg. 65
- BS/DIN Lambda Chain ...Pg. 66

Heavy Duty Roller Chains Pg. 69

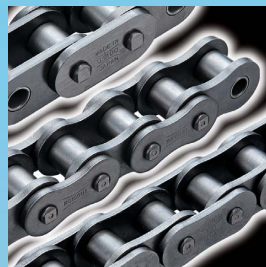

Provides higher kilowatt ratings, allowable loads, and greater tensile strength than RS Roller Chain, allowing users to go 1 – 2 sizes down.

- Super Roller ChainPg. 71
- RS-HT ChainPg. 74
- Super H Roller Chain.....Pg. 77
- Ultra Super Roller Chain ...Pg. 78

Corrosion Resistant Roller Chains Pg. 78



Provide resistance to a variety of operating environments.

- Stainless Steel Roller Chain ...Pg. 81 (SS, NS, AS, and LSC Series)
- Surface Treated Roller Chain ...Pg. 84 (NP, NEP, and APP Series)
- Titanium Roller ChainPg. 87
- Cold Resistant Roller Chain (KT Series)Pg. 87
- Low Noise Roller ChainPg. 88
- Poly Steel Chain®Pg. 90
- Curved Stainless Steel Roller ChainPg. 90

Specialty Roller Chains Pg. 91



Chains designed for special applications.

- RS® Curved Roller Chain ...Pg. 91
- Leaf ChainPg. 92

Tsubaki, bringing you an expansive line-up of drive chains and sprockets that fit your exact needs and drastically improve your productivity.

 **RS® Sprocket Standard Pilot Bore Series Pg. 98**



Wide selection of standard sprockets for general use RS Roller Chain.

RS® SprocketsPg. 98
 2A Type RS® Sprockets ...Pg. 99
 Single Dual Type Sprockets ...Pg. 100
 BS/DIN Roller Chain SprocketsPg. 133

 **Fit Bore Series Pg. 101**



Each model is provided with a finished bore, keyway, and set screws.

Fit Bore®Pg. 101

 **Lock Series Pg. 108**



RS standard sprockets can be mounted to shafts without using keys.

Lock Series S TypePg. 109
 Lock Series N TypePg. 120

 **Corrosion Resistant Series Pg. 122**



Sprockets made of excellent corrosion-resistant stainless steel, and sprockets made of engineering plastic that can be used without lubrication.

Corrosion Resistant Series ...Pg. 122
 Fit Bore® Corrosion Resistant SeriesPg. 127

 **Specialty Sprockets Pg. 133**

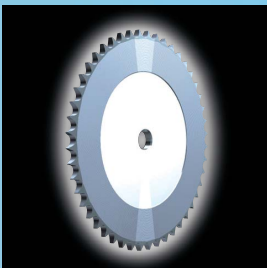

Sprockets for special applications, such as torque limiter sprockets.

Torque Limiter Sprocket ...Pg. 133



Index

 **Pin Gear Drives Pg. 142**



Pin gear drives use Tsubaki's long experience in creating drive units to provide increased performance, easier mounting, and a greater operating range. (Linear and rotating drive types available.)

Chain Type Pin Gear SprocketPg. 142
 Pin Gear Drive Unit ...Pg. 145

 **Accessories (Peripheral Instruments) Pg. 152**



Peripheral instruments for your chain maintenance needs.

Chain TensionersPg. 153
 Chain Cutting ToolsPg. 157
 Chain Connecting Tools ...Pg. 158
 End FixturesPg. 159
 Auto Lubricator for Roller Chain ...Pg. 160
 Chain Elongation Scale ...Pg. 161

Easy Bore Finishing Service Pg. 134

Sprocket Engineering Information Pg. 139

For Safe Use Pg. 208



Caution

The chains, sprockets, and other products appearing in this catalog are manufactured with care. However, if not properly selected, handled, or maintained, chains may break, resulting in serious accident. Use design materials, selection criteria, and instruction manuals as reference for selecting, handling, and maintaining chains and sprockets, and confirm any uncertainties with the manufacturer before proceeding.

New Tsubaki Roller Chains and Sprockets

RS Roller Chain G7-EX



We've expanded our innovative G7 line-up to bring you the maximum in quality.



Lube Groove Solid Bush

(Pat. No. 3982706*1)

Uses lube grooves on the inside of our seamless cold forged solid bush. Solid bushes together with lube grooves give G7-EX chains twice the wear life.

*Lube grooves (Pat.) available from RS80 – RS140 chains only.



*1 Tsubaki's unique lube groove processing (Pat.) creates grooves on the inside of the bush to help retain lubrication longer.

Twice the Wear Life

Solid lube groove bushes retain lubrication longer

Wear life comparison

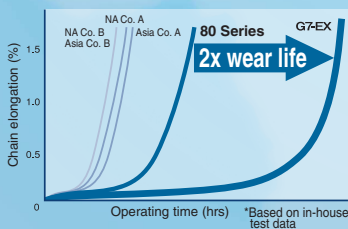

Tsubaki's unique processing expertise has given rise to our seamless solid bush. Special lube grooves in our high precision solid bush better retain lubrication, helping double the G7-EX chain wear life.

*Lube grooves (Pat.) available from RS80 – RS140 chains only.

33% Increase in kW Ratings

Realized through superior technology, equipment, and quality control at Kyotanabe Plant, the world's No. 1 chain manufacturing center.

kW Ratings Table

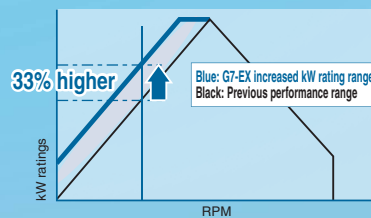

Kyotanabe Plant – expertly combining traditional manufacturing know-how with cutting-edge technology. By decreasing deviations in quality, we have increased the kW ratings of the G7-EX chain by 33%.

BS/DIN RS® Roller Chain GT4 Winner



We've made the most of our manufacturing advances with the G7-EX roller chain to bring twice the wear life to the BS/DIN Series Roller Chain.



GT4 WINNER

4th Generation BS/DIN Series Roller Chain



① Lube groove solid bush

We use innovative G7-EX technology to realize unparalleled wear resistance.

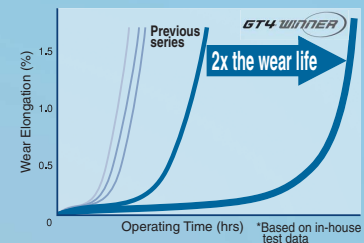

② Specially shaped pin and center sink riveting

Center sink rivets eliminate the need for pin grinding, greatly reducing chain cutting and connection time.

③ Full kW ratings table

Tsubaki has provided the world's first full kW ratings table for BS/DIN chain, making chain selection easy and accurate.

RS® Sprockets

RS Sprockets are perfect for G7-EX roller chain!

RS Sprockets are strong enough for G7-EX roller chain. While sprocket teeth are subject to wear, and require the same wear resistant qualities as roller chain, Tsubaki is proud to offer sprockets with hardened teeth for the most demanding applications.



Tsubaki RS Sprockets are high quality sprockets that have been heat treated in accordance with appropriate quality standards.

• Comparison of teeth hardening

Tsubaki RS Sprocket teeth have a hardened layer over the entire surface, right down to the teeth roots.



Cross-sectional look at sprocket teeth hardening (darker color is the hardened layer)

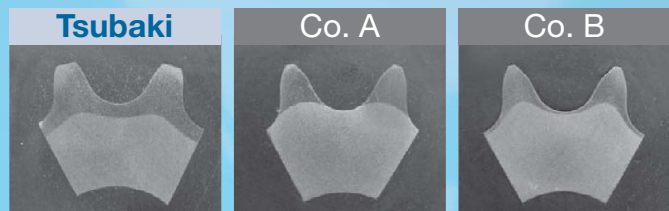

• Comparison of tooth surface wear under loaded test conditions

Here we see the amount of wear on an RS40 chain sprocket after 500hrs operation. The Tsubaki sprocket exhibits overwhelmingly superior wear performance!

Sprocket Tooth Surface Wear Comparison

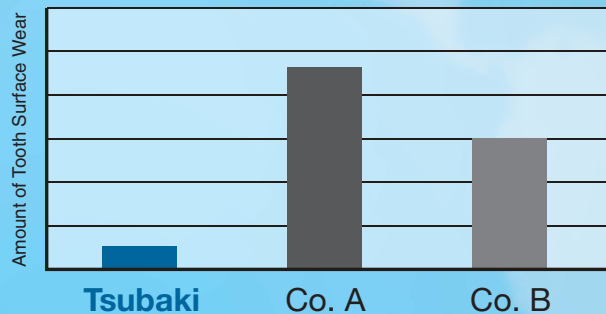

BS/DIN Series Lambda Chain



Our new BS/DIN Series Lambda Chain has even better performance

For RF06B-LM – RS16B-LM

Much of the equipment imported from Europe uses BS/DIN Series chain.

We thoroughly reviewed the bearing material, material properties, and lubrication for our Tsubaki BS/DIN Series Lambda Chain and improved its performance!

See for yourself how Tsubaki's proven performance and Made In Japan quality achieve greater efficiency and longer chain life.



50% greater wear life!

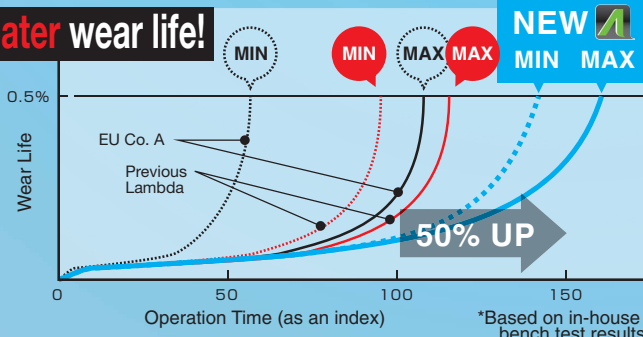

Tsubaki's unique bearing material, material properties, and lubrication bring you a Lambda Chain with a 50% longer wear life.

We've further eliminated the extremes of quality variation to give our Lambda Chain more stable performance.

*Based on in-house bench test results

Before Use

NOTE

With the exception of endless chains, the transmission power tables in this catalog are based on use with connecting parts (connecting links or offset links).

See page 12 for details on connecting parts.

This drive chain catalog explains how to select, install and maintain all listed Tsubaki Roller Chains. Numerical figures are indicated in both SI and gravimetric units.

Read through this catalog before use to ensure proper selection and usage. Also, carefully inform persons involved in installation and maintenance of all pertinent matters.

Ordinary Transmission



Lifting Applications

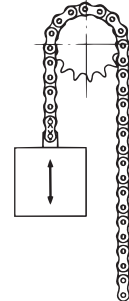

Shuttle Traction

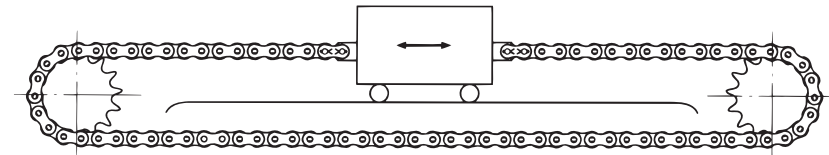

Pin Gear Drive

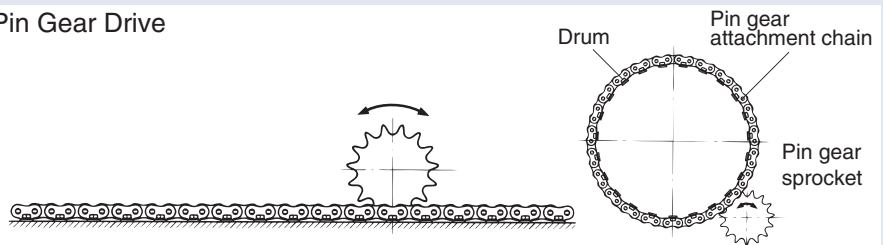

⚠ Notes on Using Roller Chains

NOTE



- When using a roller chain in lifting applications, keep clear from underneath the load.
- If there is the possibility of serious accident or death in the event of roller chain breakage during lifting or other applications, install reliable safety devices to prevent accidents.
- Inspect and replace worn roller chain periodically.
- Roller chains can break and climb up on the sprocket from wear elongation. (Lubrication can extend service life against wear elongation. Tsubaki also offers lube-free drive chains that deliver long-lasting service without lubrication.)
- Overload may cause roller chain to break. (Avoid breakage by properly selecting products with consideration of inertia, etc. Tsubaki offers heavy-duty drive chains in identical sizes that deliver the high strength of larger chains.)
- Roller chains can break due to corrosion and other environmental conditions. (Avoid breakage by preventing exposure to corrosive liquids, atmospheres, etc. Tsubaki offers excellent corrosion-resistant drive chains.)
- Correctly install roller chain to avoid misalignment or uneven wear and possible breakage.

General Comparison of Transmission Elements

The following table compares roller chains to other power transmission mechanisms such as toothed belts, V-belts and gears. Generally speaking, roller chains are often used as economical power transmission suited to low speed and high loads. However, it is also possible to use chain in high-speed applications such as camshaft drives for automobiles.

Transmission Mechanism		Roller Chain	Toothed Belt	V-belt	Gear
Synchronicity		◎	◎	×	◎
Transmission Efficiency		◎	◎	△	◎
Anti-shock		△	○	◎	×
Noise & Vibration		△	◎	◎	×
Ambient Conditions		Avoid water and dust. (Corrosion-resistant drive chains available.)	Avoid heat, oil, water and dust.	Avoid heat, oil, water and dust.	Avoid water and dust.
Space, Weight	High speed, light load	×	◎	○	○
	Low speed, heavy load	◎ Compact, lightweight	△ Slightly heavy pulleys	×	○ Needs high strength due to low number of engaging teeth.
Lubrication		×	◎	◎	×
		Required	Not required	Not required	Required
Layout Freedom		◎	○	△	×
Excess Load on Shaft		◎	○	×	◎

◎Excellent ○Good △Fair ×Poor

Features and Precautions of Roller Chain Transmissions

Features

- Accommodate large speed reductions/increases (usually up to 1:7).
- Chains can accommodate long shaft center distances (normally less than 4 m), and are more versatile.
- It is possible to use chain with multiple shafts or drives with both sides of the chain.
- Easy installation and replacement (easy to cut and connect chains).
- Drive use is possible even when shafts are vertical, as long as the chain receives support in short distances between the shafts.
- Standardization of chains under the American National Standards Institute (ANSI), the International Standardization Organization (ISO), and the Japanese Industrial Standards (JIS) allow ease of selection.
- The sprocket diameter for a chain system may be smaller than a belt pulley while transmitting the same torque.
- Sprockets are subject to less wear than gears because sprockets distribute the load over their many teeth.
- High shock absorbency compared to gears.

Precautions

- Chains have speed variation, called chordal action, which is caused by the polygonal effect of the sprockets.
(Shock can be reduced under the same speed ratio by either reducing the chain pitch or increasing the number of sprocket teeth.)
- During transmission, a method of lubrication suitable to the chain's speed is necessary.
- Chains wear and elongate. Measures for adjusting chain slack need to be considered.
- Chains are weak when subjected to loads from the side. They need proper alignment.

Glossary

1. ANSI Standard Minimum Tensile Strength (Tensile Breakage Strength)

This is the minimum tensile strength determined by ANSI Standard. If a roller chain breaks from a tensile load below this value, then it is non-compliant. With multi-strand roller chain, the single strand value is multiplied by the number of strands. (ANSI B 29.100)

2. Tsubaki Average Tensile Strength

This is a fracture load reading obtained after a long period of actual tensile strength testing of a large number of chain strands. Naturally, a roller chain may actually break at a higher or lower value than this, so it does not represent a guaranteed value. This value varies depending on the manufacturer.

3. Tsubaki Minimum Tensile Strength

This is a minimum value determined by statistical processing at Tsubaki. If any roller chain fractures by a tensile load below this value, then it is non-compliant. This value varies depending on the manufacturer.

Fig. 1 Relationship between three tensile strengths

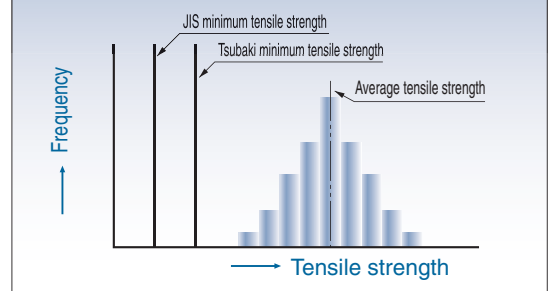

Testing Method

As shown in Fig. 2, a roller chain with over five links is fixed at both ends by clevises and is stretched until breakage occurs (JIS B 1801-2009). The type of fracture is indicated by breakage of the roller chain or failure of its parts (Fig. 3.)

Fig. 2 Tensile strength test

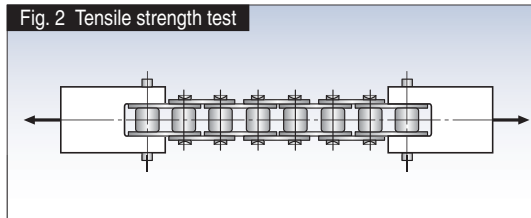
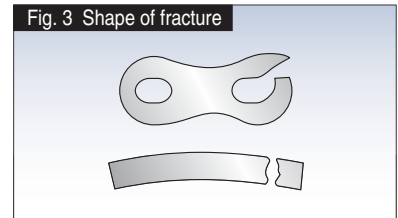

Fig. 3 Shape of fracture



4. Maximum Allowable Load

The maximum allowable load of roller chain (excluding Stainless Steel Chain and Engineering Plastic Chain*) is the value derived from the lowest fatigue limit. When a load lower than this value is repetitively applied to the roller chain, fatigue failure will never occur.

According to the former JIS B 1801-1997, the maximum allowable load indicates a breakage load of $P_{max} = (P_m + P_a) = 2.2P_a$ at a frequency of 5×10^6 , when a new roller chain with over five links receives a repetitive load in linear operation. (Fig. 4)

Tsubaki standards and catalog values are for 10^7 repetitions, or $2P_a$. In other words, if Tsubaki's maximum allowable load is indicated as maximum load (P_{max}), then values in this catalog would increase 10%.

* Stainless steel and engineered plastic chains:
Maximum allowable load is determined from specifying the surface pressure between pins and bushes based on wear performance.

Fig. 4 Summary chart of repetitive load

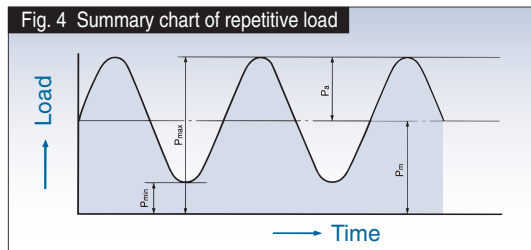

Note that strength of offset links may be lower than the chain itself.
(Refer to each product page for details.)

5. Kilowatt Ratings Table

RS Roller Chain, SUPER Roller Chain, Heavy Duty Chain, and Low Noise Drive Chain kilowatt ratings tables show kW values for 15,000 hours of operation using a two-shaft drive and 100 pitches of roller chain under conditions 1 - 5 below.

The kW ratings table of Lambda Chain is based on conditions 1 - 4 and shows kW rating values when Lambda Chain is used with two shafts. Lambda Chain has more than seven times the wear elongation of Standard RS Roller Chain operated without lubrication (#120 and #140 are over 2.5 times). X-LAMBDA has more than five times the wear elongation life of Lambda Roller Chain.

- 1) The chains are operated under ordinary conditions where the ambient temperature is -10°C – +60°C (+14°F to +140°F) and there is no abrasive dust.
- 2) There are no negative effects from corrosive gasses or high humidity.
- 3) The two shafts are level and the chains are properly installed. (See item 4 on pg. 194.)
- 4) There is minimal fluctuation in load during transmission.
- 5) The recommended lubrication system and lubricant shown in the kW ratings tables is used for RS Roller Chain and Super Roller Chain. (See pgs. 192 - 193.)

6. Moment of Inertia (I / J / GD²)

Moment of inertia is used to show the degree of inertia in rotational movement; in other words, "rotation difficulty", or "rotation ease." This is equivalent to the mass (weight) of the object being used for straight-line transmission.

Moment of inertia is shown in the SI units table as:

$$I = mk^2 \text{ (kg} \cdot \text{m}^2 \text{ m: mass of rotating body k: turning radius)}$$

It is shown in the Gravimetric units table as:

$$J = \frac{G}{G} \cdot K^2 \text{ (kgf} \cdot \text{m} \cdot \text{s}^2 \text{ G: mass of rotating body G: gravitational acceleration)}$$

Although, $GD^2 = 4GJ$ (D: diameter of rotating body) is generally being used now in place of moment of inertia.

7. Total Length Tolerance of Roller Chain

Length test method and length tolerance are specified in JIS B 1801-2009. The length tolerance of any individual size when subjected to a measured load (e.g. 500 N [50.99 kgf] for RS 80) specified in JIS is 0 to +0.15% of the reference length. The reference length is calculated by multiplying the reference pitch (P) by the number of links. (Applicable to products bearing a JIS identification number.)

8. Elastic Elongation of Chain under Load

An elastic elongation curve of a chain under load looks as shown below. Values shown here are the standard references for single-strand RS Roller Chains. Actual values may slightly differ. Do not apply loads greater than the maximum allowable load to roller chains.

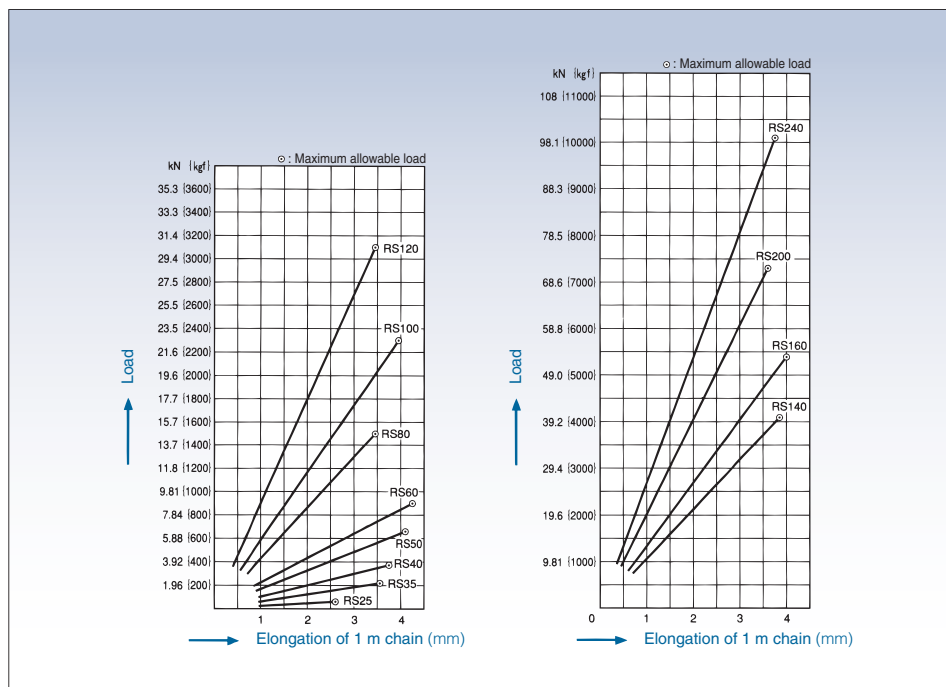

Roller Chain Construction

1. Basic Structure (Photo: RS Roller Chain)

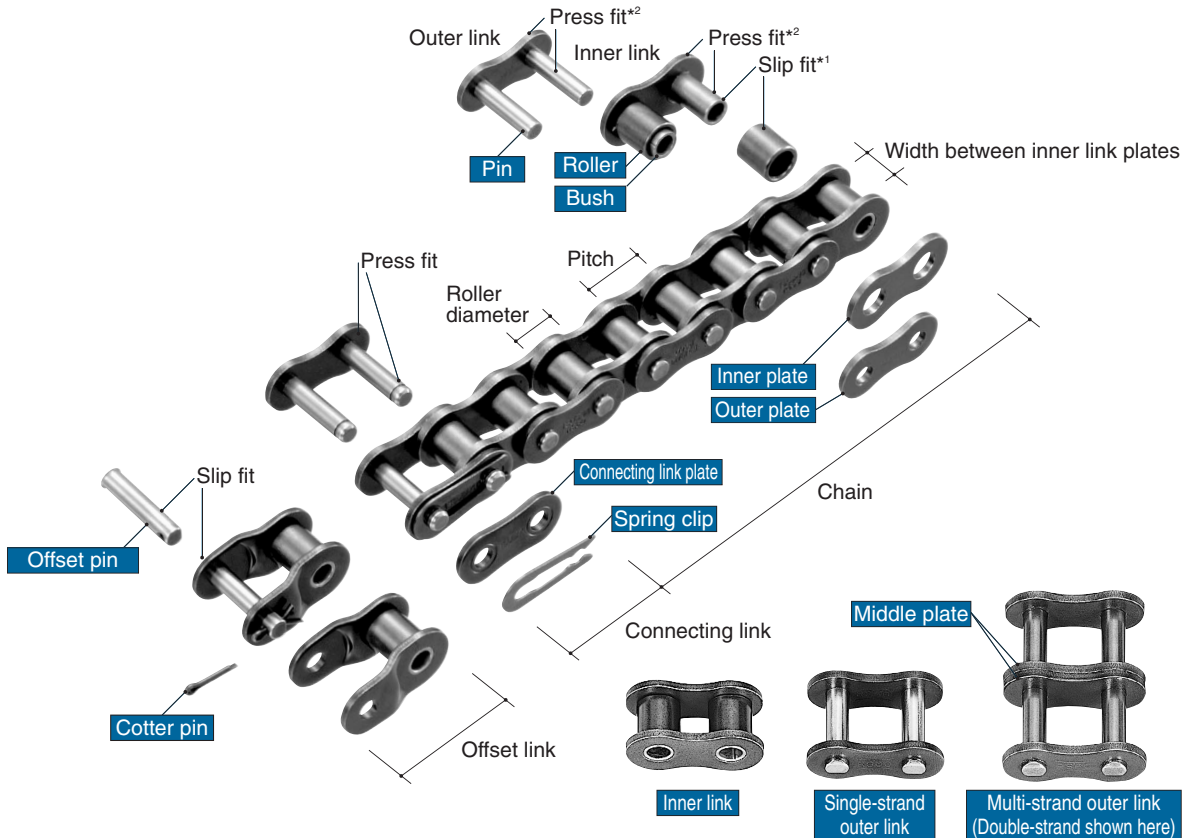

Basic Three Dimensions

The pitch, roller diameter, and inner width of the inner link are considered the basic three dimensions of a roller chain. When these dimensions are identical, a roller chain and sprocket are dimensionally compatible.



Spring clips, cotter pins and spring pins are essential parts that prevent connecting plates from falling off, maintaining the strength of the chain itself. Always install these parts.

*1Slip Fit

When the shafts and holes are fitted together, there is a continuous loose fit. This is a fit where the range of tolerance for the hole is larger than the range of tolerance for the shaft (pin or bush).

*2Press Fit

When the shafts and holes are fitted together, there is a continuous interferential fit. This is a fit where the range of tolerance for the hole is smaller than the range of tolerance for the shaft (pin or bush).

■ Plate

The plate bears the tension placed on the chain. Usually this is a repetitive load, but sometimes it is accompanied by shock. Therefore, the plate must have not only great static tensile strength, but also must hold up to the dynamic forces of load and shock.

■ Pin

The pin is subject to shearing and bending forces transmitted by the plate. At the same time, it forms a load-bearing part, together with the bush, when the chain flexes during sprocket engagement. Therefore, the pin needs high tensile and shear strength, resistance to bending, and sufficient endurance against shock and wear.

■ Bush

The bush is subject to complex forces from all parts, especially from the repetition of shock loads when the chain engages the sprocket. Therefore, the bush needs extremely high shock resistance. In addition, the bush forms a load-bearing part together with the pin, and as such requires great wear resistance.

■ Roller

The roller is subject to impact load as it strikes the sprocket teeth during chain engagement with the sprocket. After engagement, the roller changes its point of contact and balance. It is held between the sprocket teeth and bush, and moves on the tooth face while receiving a compression load. Therefore, it must be resistant to wear and still have strength against shock, fatigue and compression. RS11 / 15 / 25 / 35 do not have rollers.

■ Roller Link

Two bushes are press fit into two inner plates, and rollers are inserted to allow rotation around the outside of the bush. This is the same for single-strand and multi-strand chain.

■ Outer Link and Middle Plate

The pin link consists of two pins that have been press fit into two outer plates. With multi-strand roller chain, a middle plate is added to the pin link. The middle plate is slip fit for standard RS Roller Chain and press fit for Super Roller Chain.

2. Assembly Parts

Roller Chains are usually made up of a number of connected links in an endless formation, or used by fixing the chain ends, but the need for connecting links will eventually arise. Although offset links can be used when there are an odd number of links in the roller chain, please use a design that requires an even number of links as much as possible. Please note that connecting links and offset links are normally coated with an anti-rust agent only. Always thoroughly lubricate pin and bush when assembling.

2.1 Connecting Links

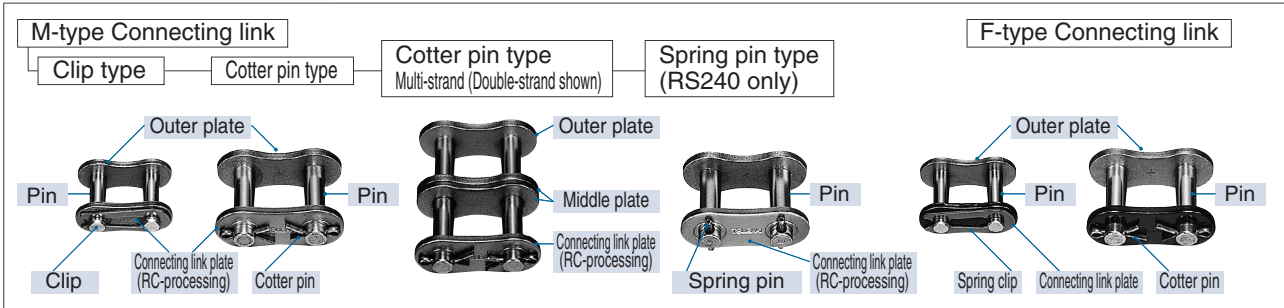

Chain type	Connecting link type	Pin / Connecting link plate fitting	Connecting link plate fastening	Note
RS Roller Chain	M-type connecting link Code: CL	Slip fit (M)	Spring clip Cotter pin Spring pin	<ul style="list-style-type: none"> For multi-strand chain, make sure the plate with *Ring coining is on the outermost side when assembling. Operating speed is indicated by the white area in the kW ratings table.
	F-type connecting link * Code: FCL	Press fit	Spring clip, Cotter pin Spring pin T-pin	<ul style="list-style-type: none"> Make sure to use the chain according to the specified applications on page 131 and within the speed region of the colored area in the kW rating tables.
Lambda Chain	M-type connecting link Code: CL	Slip fit (M)	Spring clip Cotter pin	<ul style="list-style-type: none"> Can be used in all areas of the kW ratings table for Lambda Chain. Connecting plates are ring coined.
Super Roller Chain	M-type connecting link Code: MCL	Slip fit (M)	Spring pin	<ul style="list-style-type: none"> Connecting plates are ring coined.
	F-type connecting link Code: FCL	Press fit	Spring pin	<ul style="list-style-type: none"> Use under extreme conditions (e.g., high shock, very high load, possible side force, etc.).
Super-H Roller Chain	F-type connecting link Code: CL	Press fit	Spring pin	<ul style="list-style-type: none"> Use exclusive connecting link.
Heavy Duty Roller Chain	F-type connecting link Code: CL	Press fit	Cotter pin Spring pin	<ul style="list-style-type: none"> Use exclusive connecting link.
Other roller chains in catalog	M-type connecting link Code: CL	Slip fit (M)	Cotter pin, Spring clip Spring pin T-pin, Z-pin	<ul style="list-style-type: none"> Refer to individual dimension diagrams. Only NP, NEP and Low Noise Roller Chains use ring coined connecting link plates.

Note 1. The connecting link plate fastening method for each chain size is indicated in the dimension tables and the table notes.

2. The color of F-type connecting links for RS Roller Chain and RS-HT Roller Chain marked with * is black.

Remark: Ring Coin (RC) Processing

This Tsubaki original processing adds an area of plastic deformation around pin holes to generate residual stress around the holes.



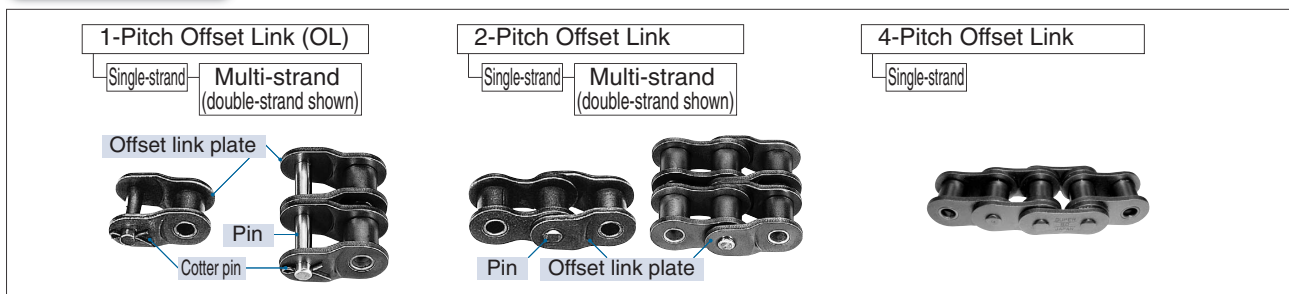

Ring Coin Processing

2.2 Offset Link



Note: See the dimensional tables for roller chain types and sizes suitable for offset links.

Roller Chain and Specialty Chain Lineup

Series	Product	Features/Applications	Operating temperature range (°C)
 Standard Roller Chains	RS Roller Chain	JIS-, ISO-compliant	-10 to +60*1
	BS/DIN Standard RS Roller Chain	ISO-compliant series	
 Lube-Free Roller Chains	Lambda Chain	Lube-free, long-life (Special oil-impregnated bush)	-10 to +150
	Surface Treated Lambda Chain	Lube-free, long-life (Special oil-impregnated bush) Surface treated (NP and NEP)	
	X-Lambda Chain	Super long-life via special oil-impregnated bush and felt seal	
	Lambda Chain KF Series	Lube-free, long-life (Special oil-impregnated bush), for high temperatures and food processing equipment.	-10 to +150*2
	Heavy Duty Lambda Chain	Lube-free, long-life (Special oil-impregnated bush), heavy-duty, double-strand only	-10 to +150
	Curved Lambda Chain	Lube-free, long-life (Special oil-impregnated bush), for curved lines	
	BS Lambda Chain	Lube-free, long-life (Special oil-impregnated bush), ISO-compliant BS Series	
Heavy Duty Roller Chains	Heavy Duty Roller Chain	High tensile strength (Approx. 19% increase over RS)	-10 to +60*1
	Super Roller Chain	High tensile strength (Approx. 30% increase over RS)	
	Super-H Roller Chain	High fatigue strength, high tensile strength, for heavy-duty transmissions	
	Ultra Super Roller Chain	Maximum fatigue strength, maximum tensile strength, for super heavy-duty transmissions	
Corrosion Resistant Roller Chains	Stainless Steel Roller Chain	SS ... High corrosion resistance, high heat resistance	-20 to +400
		NS ... Higher corrosion resistance and higher heat resistance than SS	
		AS ... 1.5x maximum allowable load of SS, slightly less corrosion resistance	
		LSC ... Greater wear resistance than SS Series	
	Surface Treated Roller Chain	NP ... Low corrosion resistance, special nickel plating	-10 to +60*1
		 NEP ... High corrosion resistance	
		APP ... Anti-pitting	
	Titanium Roller Chain	Made of nonmagnetic titanium, high corrosion resistance	-20 to +400
	Cold Resistant Roller Chain	Cold resistance specification	-40 to +60*1
	Low Noise Roller Chain	Spring rollers, low noise	-10 to +60*1
Poly Steel Chain	Corrosion resistance, wear resistance, low noise, lightweight	-20 to +80	
Curved Stainless Steel Roller Chain	Stainless steel, curved transmissions	-20 to +400	
Specialty Roller Chains	Curved Roller Chain	Side-flexing chain, curved transmissions	-10 to +60*1
	Leaf Chain	Plate and pin construction, for lifting applications, AL-type, BL-type (AL ...), (BL ...)	
	Pin Gear Attachment Chain	Used in anchored configuration, gear transmission	



Eco Link Mark

These new products meet our voluntary eco assessment criteria.

Chain No. (Pitch: mm) *2															Ref. page
11 (3.7465)	15 (4.7625)	25 (6.35)	35 (9.525)	40 (12.70)	50 (15.875)	60 (19.05)	80 (25.40)	100 (31.75)	120 (38.10)	140 (44.45)	160 (50.80)	180 (57.15)	200 (63.50)	240 (76.20)	
	●	●	●	●	●	●	●	●	●	●	●	●	●	●	15
		*6	RFO6B ●	RS08B ●	RS10B ●	RS12B ●	RS16B ●	RS20B ●	RS24B ●	RS28B ●	RS32B ●		RS40B ●	RS48B ●*6	
				●	●	●	●	●	●	●					55
				●	●	●	●	●	●	●					
				●	●	●	●	●	●						
				●	●	●	●	●	●						
			RFO6B ●	RS08B ●	RS10B ●	RS12B ●	RS16B ●	RS20B ●	RS24B ●	RS28B ●	RS32B ●		RS40B ●		
						●	●	●	●	●	●		●	●	69
							●	●	●	●	●		●	●	
								●	●	●	●		●	●	
●		●	●	●	●	●	●	●	●	●	●	●	●	●	79
		●	●	●	●	●	●	●	●	●	●	●	●	●	
				●	●	●	●	●	●	●	●	●	●	●	
				●	●	●	●	●	●	●	●	●	●	●	
		●	●	●	●	●	●	●	●	●	●	●	●	●	
			●	●	●	●	●	●	●	●	●	●	●	●	
			●	●	●	●	●	●	●	●	●	●	●	●	
			●	●	●	●	●	●	●	●	●	●	●	●	
		●	●	●	●	●	●	●	●	●	●	●	●	●	
				●	●	●	●	●	●	●	●	●	●	●	
				4	5	6	8	10	12	14	16				91
				●	●	●	●	●	●	●	●		●	●	
				●	●	●	●	●	●	●	●		●	●	

*1: The operating temperature range of pre-lubricated chains (those coated with oil when delivered) is -10 to +60°C (-40 to +60°C for KT specification).

Chain kW ratings do not decrease until 150°C. To use in +60 to 150°C environments, apply a high temperature lubrication. For details and precautions in usage, see "Temperature Selection Method" (page 188) and "Roller Chain Lubrication" (page 192).

*2: Lambda Chain KF Series gives better lubrication performance in high temperature ranges (from ambient temperatures to ~230°C. When using in the 150°C - 230°C range, refer to pg. 188 for temperature selection methods.

*3: RS11-SS-1 comes lubricated.

*4: Operating temperature range when using stainless steel rollers. Operating temperature range for plastic rollers is -20°C to 80°C.

*5: Sizes marked with ● are standard products shown in this catalog. For details, see the corresponding section. Blank cells are specialty items and may be specially ordered. Contact a Tsubaki representative for details.

*6: RS05B (pitch 8.00) and RS56B (pitch 88.9) are also available.

Ordering RS Roller Chain

The following example uses an RS Roller Chain.

Ordering is basically the same for other products, but some products are unavailable. See each section for details.

1. Ordering by Unit

With the exception of special specification chains, RS Roller Chain is normally stocked by unit. The total length of one unit includes one connecting link. Please purchase additional connecting links if you intend to separate the chain into two or more sections or join chains to create a longer chain.

Length of one unit: 3048 mm (10 feet); however
RS11-SS: 502 mm, RS15: 1000 mm,
RS25: 1016 mm, RS140: 3023 mm, RS180: 3086 mm.

Ordering example



Ordering n units of RS80-1

Product code	Chain number	Count	Units
A110113	RS80-1-RP-U	n	U (unit)

Ordering pieces of RS80-1 CL and OL

Product code	Chain number	Count	Units
A115031	RS80-1-CL	n	K (pcs)
A116025	RS80-1-OL	n	K (pcs)

Note: When ordering CL, note that there are two types: M-type CL and F-type CL.

- ▶ For M-type CL
Example: RS80-1-CL
- ▶ For F-type CL, write FCL.
Example: RS80-1-FCL

Example:

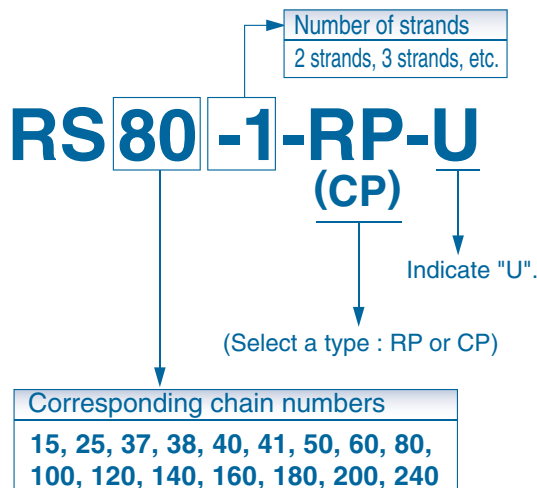

Note: RP (rivet pin) is when the inner plates are connected by the outer plates via riveting.
CP (cotter pin) is when the inner plates are connected by the outer plates via cotter pins.

2. Ordering an Even Number of Links

Be sure to indicate configuration specification.

1 When the number of links is 8



8 links including the connecting link (CL)

Ordering example

Ordering 8 links of RS50-1 Roller Chain

Product code	Chain number	Count	Units
A110018	RS50-1-RP	7	L
A115018	RS50-1-CL	1	K

- ▶ Indicate the number of links of the chain segment only.
Example: In the case of 8LX2H, the chain segment is 14L with CL2K
In the case of 8LX3H, the chain segment is 21L with CL3K

Configuration specification

8LX 1H (number)

Specify the number of chains required.

2 20-link complete endless



Ordering example

Ordering 20-link complete endless RS50-1-RP

Product code	Chain number	Count	Units
A110018	RS50-1-RP	20	L

Configuration specification

20LX 1H (number)(complete endless)

Specify the number of chains required.

3. Matched and Tagged Chain

Deviations in chain length exist due to the manufacturing tolerances of the parts. When chains are to be used in parallel and minimizing the relative difference in the lengths is necessary, request a "matched and tagged" chain.

Note: A separate charge is required for a length matching.

Example entry in special mention column

For example, if you need three sets of two single-strand, 120-link RS80 chains, the entry should be:

RS80-1-RP 720 links

Matched and tagged chain: 120 L x 2 H x 3 D

4. Long Length Formation

Chains whose total length exceeds one unit (3048mm) are called long length formations. Chains that exceed the lengths below are super long length formations and are delivered connected in special boxes. Additional fees apply.

	RS25~RS180	RS200	RS240
Single strand	2.5 units	100 links	70 links
Multi-strand	Contact a Tsubaki representative		

5. Reel Chain

Single-strand RS25 to RS80 chain (see table below) is available on long-length reels.

■ Ordering example

Ordering one reel of RS50-1-RP Roller Chain

Product code	Chain number	Quantity	Units
A110089	RS50-1-RP-10UR	1	R



Product code	Chain number	Units per reel	Number of links (unit: L)	Number of accessory CL (M-type connecting links)
A110083	RS25-1-RP-150UR	150	23999	150
A110084	RS35-1-RP-20UR	20	6399	20
A110085	RS37-1-RP-20UR	20	4799	20
A110086	RS38-1-RP-20UR	20	4799	20
A110087	RS41-1-RP-20UR	20	4799	20
A110088	RS40-1-RP-15UR	15	3599	15
A110089	RS50-1-RP-10UR	10	1919	10
A110090	RS60-1-RP-10UR	10	1599	10
A110091	RS80-1-RP-5UR	5	599	5

6. Replacement Precautions

When you do not know the roller chain number

1

Verification of the roller chain specifications (strength type, material, etc.) is important. Check with the manufacturer.

2

Check the roller chain size and specifications that are engraved on the roller chain plate.

3

Measure the pitch, roller diameter, inner width of inner link, and plate thickness of the roller chain.

RS® Sprocket Guide and Ordering Example

1 RS Sprocket Standard Pilot Bore Series

RS Sprockets are for RS Roller Chain (JIS/ISO standards).

With the Pilot Bore Series, the shaft hole is the pilot bore, and so will require processing before use.

(RS25 sprockets have an H8 pilot bore and are tapped. Other sizes have an H10 pilot bore.)

- ① RS Sprocket standard pilot bore (1B, 1C, 2B, 2C, 1A types).....Pgs 18 – 45
- ② RS Sprocket standard pilot bore (2A type, single dual).....Pg. 99

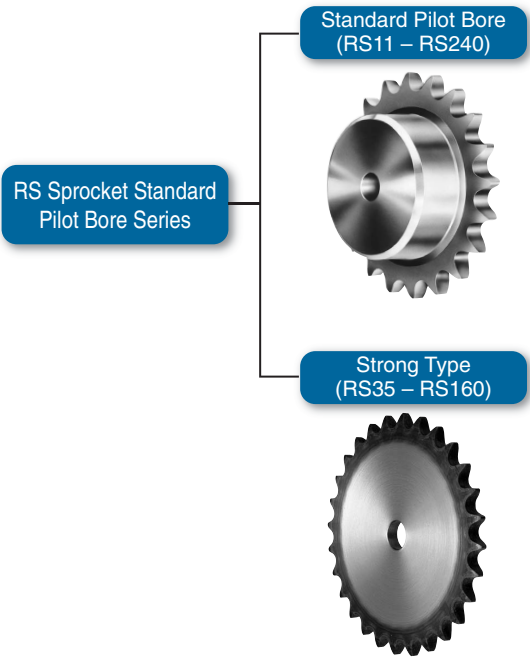

Standard Pilot Bore (RS11 – RS240)
Extensive line-up of standard sprockets. Tsubaki also offers single dual (SD) type sprockets, which accommodate two strands of chain. Sprockets with small numbers of teeth have hardened teeth, while those with large numbers of teeth are not heat treated.

Strong Type (RS35 – RS160)
Features hardened teeth for sprockets with a large number of teeth. Strong Series sprockets are high quality sprockets with teeth hardened to the appropriate quality standards.

*The classification of small or large numbers of teeth varies with sprocket size. See each sprocket's dimensional chart for details.

Teeth Specifications

■ Hardened teeth

Use a sprocket with hardened teeth when better strength and wear resistance are required. Sprocket teeth are hardened on sprockets with a small number of teeth and on RS Strong Type Sprockets.

■ Unhardened teeth

Sprocket teeth are not heat treated. Sprocket teeth are not heat treated on RS Sprockets with a large number of teeth.

● Example: RS40-1B

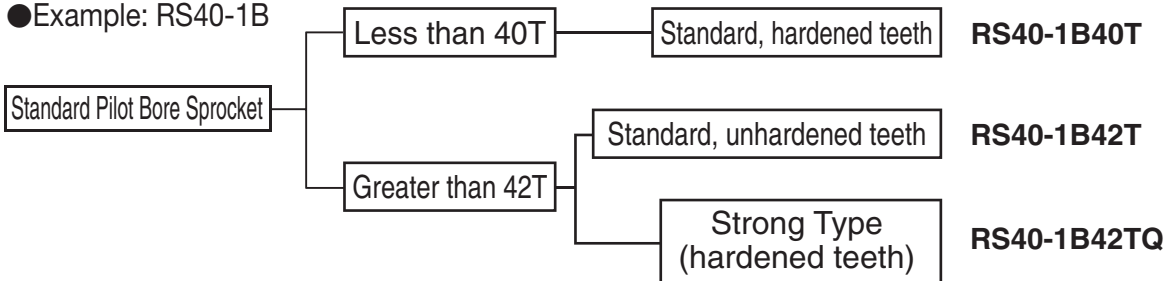

2 Fit Bore® Series

Each model is provided with a finished bore, keyway, and set screws.....Pg. 101

3 Lock Series

RS standard sprockets can be mounted to shafts without using keys.....Pg. 108

Ordering Example for RS Sprocket Standard Pilot Bore Series

Please indicate product code and model number on your order.

■ Ordering Example

(Standard Pilot Bore Type)

Product code	Model Number	Qty.
G110189	RS40-1B50T	10

(Strong Type)

Product code	Model Number	Qty.
G110189	RS40-1B50TQ	10

■ Model Numbering Example

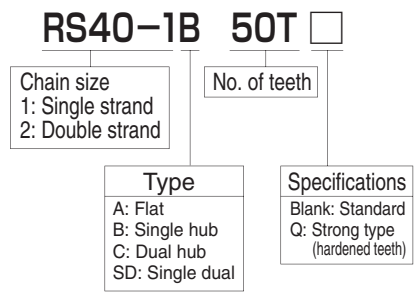

RS15

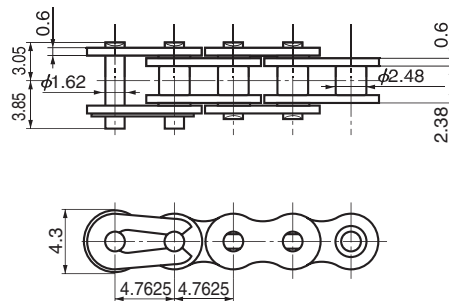

Drawing Scale 1.5/1

TSUBAKI Chain Number	Minimum Tensile Strength kN{kgf}	Average Tensile Strength kN{kgf}	Maximum Allowable Load kN{kgf}	Approximate Mass g/m	Number of Links Per Unit
RS15-1	1.77{180}	2.26{230}	0.31{32}	75	210

Note: 1. No offset links available.
2. Bushed chain.

RS15 Sprocket

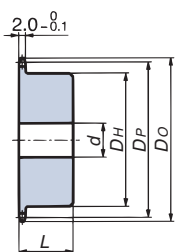

Mechanically machined 1B type

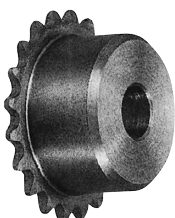

Number of Teeth	Pitch Circular Diameter (DP)	Sprocket Outer Diameter (DO)	Bore Diameter (d)		Hub		Approximate Weight (g)	Material
			Pilot Bore Diameter	Maximum	Diameter (DH)	Length (L)		
11	16.90	19.0	4	7	11	10	9	Machine-structural carbon steel
12	18.40	20.5	4	8	12	10	10	
13	19.90	22.0	4	9	14	10	14	
14	21.40	23.5	6	10	15	12	17	
15	22.91	25.0	6	12	17	12	22	
16	24.41	26.5	8	12	18	12	23	
17	25.92	28.0	8	14	20	14	32	
18	27.43	29.5	8	14	22	14	40	
19	28.93	31.0	8	15	23	14	44	
20	30.44	32.5	8	15	24	14	49	
21	31.95	34.0	8	17	26	14	57	
22	33.46	35.5	8	17	27	14	62	
23	34.98	37.5	8	17	28	14	68	
24	36.49	39.0	8	20	30	16	88	
25	38.00	40.5	8	20	32	16	100	
26	39.51	42.0	10	22	33	16	104	
27	41.02	43.5	10	25	35	16	117	
28	42.54	45.0	10	25	37	16	131	
29	44.05	46.5	10	25	38	16	139	
30	45.56	48.0	10	25	39	16	147	
31	47.08	49.5	10	25	40	18	175	
32	48.59	51.0	10	25	40	18	176	
33	50.10	52.5	10	25	40	18	178	
34	51.62	54.0	10	25	40	18	180	
35	53.13	55.5	10	25	40	18	182	

Note: 1. Bore diameter noted above is the typical range. Determine bore diameter and key bearing pressure based on general mechanical design.
2. Pilot bore diameters are finished to an H10 tolerance.

Sprocket Number

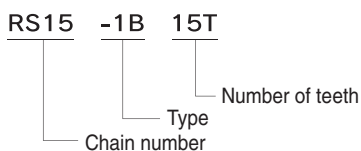

RS25, BF25-H-1

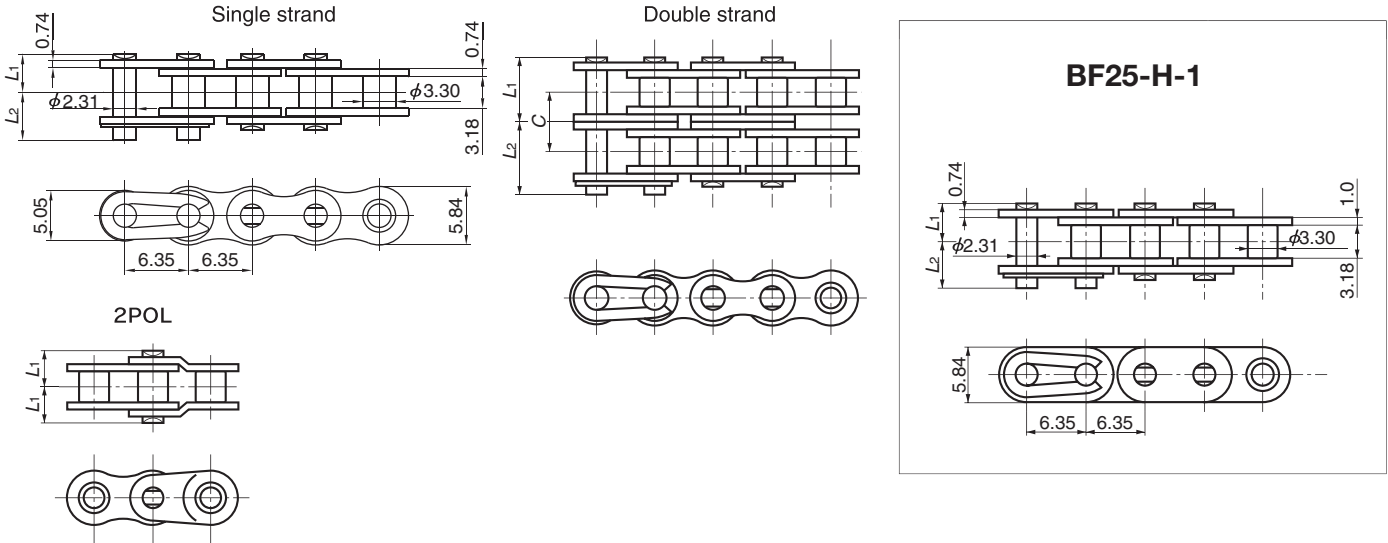

Drawing Scale 1.25/1

TSUBAKI Chain Number	Number of Strands	Pin Length L ₁ +L ₂	Dimensions L ₁	Dimensions L ₂	Transverse Pitch C	Pin Type	ANSI Standard Min. Tensile Strength kN{kgf}	Tsubaki Minimum Tensile Strength kN{kgf}	Tsubaki Average Tensile Strength kN{kgf}	Maximum Allowable Load kN{kgf}	Approximate Mass kg/m
RS25-1	1	8.3	3.8	4.5	-	Riveting	3.6 {367}	4.12 {420}	4.71 {480}	0.64 {65}	0.14
RS25-2	2	14.7	6.95	7.75	6.4		7.2 {734}	8.24 {840}	9.41 {960}	1.08{110}	0.27
RS25-3	3	21.1	10.15	10.95	6.4		10.8{1101}	12.4{1260}	14.1{1440}	1.57{160}	0.42
BF25-H-1	1	8.82	4.01	4.81	-		- { - }	4.9 {500}	5.88 {600}	0.78 {80}	0.17

Note: 1. The offset link of RS25 is a two-pitch offset link only. 2. BF25H has no offset links. 3. Number of links per unit =160
 4. RS25 and BF25H are both bushed chains.
 *Maximum allowable load when using an M type connecting link is 80% of the above.

■ RS25-1 Maximum Kilowatt Ratings Table (kW Ratings for Single Strand Chain)

Small Sprocket No. of Teeth	Small Sprocket Max rpm																								
	50	100	300	500	700	900	1200	1500	1800	2100	2500	3000	3500	4000	4500	5000	5500	6000	6500	7000	7500	8000	8500	9000	10000
9	0.02	0.03	0.08	0.13	0.18	0.23	0.30	0.36	0.43	0.49	0.57	0.67	0.78	0.76	0.64	0.55	0.47	0.41	0.37	0.33	0.30	0.27	0.25	0.23	0.19
10	0.02	0.04	0.10	0.15	0.20	0.26	0.33	0.41	0.48	0.55	0.64	0.76	0.87	0.89	0.75	0.64	0.55	0.49	0.43	0.39	0.35	0.32	0.29	0.26	0.23
11	0.02	0.04	0.11	0.17	0.23	0.28	0.37	0.45	0.53	0.61	0.71	0.84	0.96	1.03	0.86	0.74	0.64	0.56	0.50	0.44	0.40	0.36	0.33	0.30	0.26
12	0.02	0.04	0.12	0.18	0.25	0.31	0.40	0.49	0.58	0.67	0.78	0.92	1.06	1.17	0.98	0.84	0.73	0.64	0.57	0.51	0.46	0.41	0.38	0.35	0.30
13	0.03	0.05	0.13	0.20	0.27	0.34	0.44	0.54	0.63	0.73	0.85	1.00	1.15	1.30	1.11	0.95	0.82	0.72	0.64	0.57	0.52	0.47	0.43	0.39	0.33
14	0.03	0.05	0.14	0.22	0.29	0.37	0.48	0.58	0.69	0.79	0.92	1.09	1.25	1.41	1.24	1.06	0.92	0.80	0.71	0.64	0.58	0.52	0.48	0.44	0.37
15	0.03	0.05	0.15	0.23	0.32	0.40	0.51	0.63	0.74	0.85	0.99	1.17	1.35	1.52	1.37	1.17	1.02	0.89	0.79	0.71	0.64	0.58	0.53	0.49	0.41
16	0.03	0.06	0.16	0.25	0.34	0.43	0.55	0.67	0.79	0.91	1.07	1.26	1.44	1.63	1.51	1.29	1.12	0.98	0.87	0.78	0.70	0.64	0.58	0.54	0.46
17	0.03	0.06	0.17	0.27	0.36	0.45	0.59	0.72	0.85	0.97	1.14	1.34	1.54	1.74	1.66	1.42	1.23	1.08	0.95	0.85	0.77	0.70	0.64	0.59	0.50
18	0.04	0.07	0.18	0.28	0.39	0.48	0.63	0.76	0.90	1.04	1.21	1.43	1.64	1.85	1.81	1.54	1.34	1.17	1.04	0.93	0.84	0.76	0.70	0.64	0.55
19	0.04	0.07	0.19	0.30	0.41	0.51	0.66	0.81	0.96	1.10	1.28	1.51	1.74	1.96	1.96	1.67	1.45	1.27	1.13	1.01	0.91	0.83	0.75	0.69	0.59
20	0.04	0.07	0.20	0.32	0.43	0.54	0.70	0.86	1.01	1.16	1.36	1.60	1.84	2.07	2.11	1.81	1.57	1.37	1.22	1.09	0.98	0.89	0.81	0.75	0.64
21	0.04	0.08	0.21	0.34	0.45	0.57	0.74	0.90	1.06	1.22	1.43	1.69	1.94	2.18	2.28	1.94	1.68	1.48	1.31	1.17	1.06	0.96	0.88	0.80	0.69
22	0.04	0.08	0.22	0.35	0.48	0.60	0.78	0.95	1.12	1.29	1.50	1.77	2.04	2.30	2.44	2.08	1.81	1.58	1.41	1.26	1.13	1.03	0.94	0.86	0.74
23	0.05	0.09	0.23	0.37	0.50	0.63	0.82	1.00	1.17	1.35	1.58	1.86	2.14	2.41	2.61	2.23	1.93	1.69	1.50	1.34	1.21	1.10	1.00	0.92	0.79
24	0.05	0.09	0.25	0.39	0.53	0.66	0.85	1.04	1.23	1.41	1.65	1.95	2.24	2.52	2.78	2.37	2.06	1.81	1.60	1.43	1.29	1.17	1.07	0.98	0.84
25	0.05	0.10	0.26	0.41	0.55	0.69	0.89	1.09	1.28	1.48	1.73	2.03	2.34	2.64	2.93	2.52	2.19	1.92	1.70	1.52	1.37	1.25	1.14	1.04	0.89
26	0.05	0.10	0.27	0.42	0.57	0.72	0.93	1.14	1.34	1.54	1.80	2.12	2.44	2.75	3.06	2.68	2.32	2.04	1.81	1.62	1.46	1.32	1.21	1.11	0.95
28	0.06	0.11	0.29	0.46	0.62	0.78	1.01	1.23	1.45	1.67	1.95	2.30	2.64	2.98	3.31	2.99	2.59	2.28	2.02	1.81	1.63	1.48	1.35	1.24	1.06
30	0.06	0.12	0.31	0.49	0.67	0.84	1.09	1.33	1.56	1.80	2.10	2.48	2.85	3.21	3.57	3.32	2.88	2.52	2.24	2.00	1.81	1.64	1.50	1.37	1.17
32	0.07	0.12	0.33	0.53	0.72	0.90	1.16	1.42	1.68	1.93	2.25	2.66	3.05	3.44	3.83	3.65	3.17	2.78	2.47	2.21	1.99	1.81	1.65	1.51	1.29
35	0.07	0.14	0.37	0.58	0.79	0.99	1.28	1.57	1.85	2.12	2.48	2.93	3.36	3.79	4.21	4.18	3.62	3.18	2.82	2.52	2.28	2.07	1.89	1.73	1.48
40	0.08	0.16	0.43	0.67	0.91	1.14	1.48	1.81	2.13	2.45	2.87	3.38	3.88	4.38	4.87	5.11	4.43	3.89	3.45	3.08	2.78	2.52	2.30	2.11	1.81
45	0.10	0.18	0.48	0.77	1.04	1.30	1.68	2.06	2.42	2.78	3.26	3.84	4.41	4.97	5.53	6.08	5.28	4.64	4.11	3.68	3.32	3.01	2.75	2.52	2.15

Note: 1. Please contact a Tsubaki representative prior to use of kW ratings in the colored area of the table.

Multi-strand factor	Number of chain strands	Multi-strand factor	Lubrication method	A	Manual lubrication or drip lubrication	Details on Pg. 193
	Double strand	1.7		B	Oil bath or slinger disc lubrication	
	Triple strand	2.5		C	Forced pump lubrication	

Before Use | Standard Roller Chains | Lubrication | Heavy Duty Roller Chains | Corrosion Resistant Roller Chains | Specialty Roller Chains | Sprockets | Pin Gear Drives | Accessories | Selection | Handling

RS25, BF25-H Sprocket

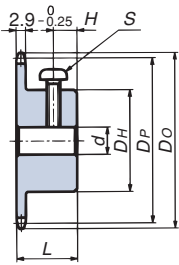

Notes:
1. Bores are finished and fitted with a screw.

Sintered alloy specification (1B type)

Sprocket Number

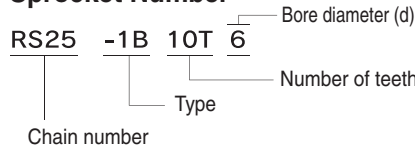

Number of Teeth	Pitch Circular Diameter (DP)	Sprocket Outer Diameter (DO)	Bore Diameter (d)		Hub		Cross-recessed Head Machine Screw		Approx. Mass (g)	Material
			1 type	2 type	Diameter (DH)	Length (L)	Position (H)	S		
10	20.55	23.5	6H8	8H8	13	14	4	M3X6	13	Sintered alloy
11	22.54	25.5	6H8	8H8	15	14	4	M3X8	16	
12	24.53	27.5	8H8	10H8	17	14	4	M4X8	20	
13	26.53	29.5	8H8	10H8	18	14	4	M4X8	23	
14	28.54	31.5	8H8	10H8	19	14	4	M4X8	26	
15	30.54	33.5	8H8	10H8	20	14	4	M4X10	31	
16	32.55	35.5	8H8	10H8	21	16	5	M4X10	38	
17	34.56	37.5	8H8	10H8	23	16	5	M4X10	45	
18	36.57	39.5	8H8	10H8	25	16	5	M4X12	52	
19	38.58	41.5	8H8	10H8	26	16	5	M4X12	60	
20	40.59	43.5	8H8	10H8	28	16	5	M4X14	68	Machine-structural carbon steel
21	42.61	45.5	8H8	10H8	30	18	7	M4X14	80	
22	44.62	48.0	8H8	10H8	30	18	7	M4X14	84	
23	46.63	50.0	8H8	10H8	30	18	7	M4X14	88	
24	48.65	52.0	8H8	10H8	30	18	7	M4X14	93	
25	50.66	54.0	8H8	10H8	30	18	7	M4X14	98	
26	52.68	56.0	10H8	12H8	30	18	7	M4X14	98	
28	56.71	60.0	10H8	12H8	30	18	7	M4X14	103	
30	60.75	64.0	10H8	12H8	30	18	7	M4X14	110	
32	64.78	68.0	10H8	12H8	30	18	7	M4X14	117	

RS37-1, RS38-1, RS41-1

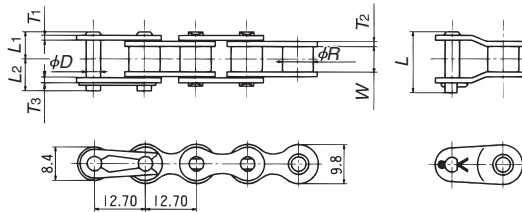

*Maximum allowable load when using an M type connecting link is 80% of the above.

■ RS41-1 Maximum Kilowatt Ratings Table (kW Ratings for Single Strand Chain)

TSUBAKI Chain Number	Pitch P	Roller Diameter R	Inner Width of Inner Link W	Plates			Pins				
				T ₁	T ₂	T ₃	D	L ₁ +L ₂	L ₁	L ₂	L
RS37-1	12.70	7.80	3.40	1.0	1.0	1.2	3.63	11.0	5.1	5.9	12.45
RS38-1	12.70	7.80	4.80	1.1	1.1	1.2	3.63	13.1	6.0	7.1	14.1
RS41-1	12.70	7.77	6.38	1.25	1.25	1.25	3.59	14.7	6.75	7.95	15.1

TSUBAKI Chain Number	ANSI Standard Min. Tensile Strength kN{kgf}	Tsubaki Minimum Tensile Strength kN{kgf}	Tsubaki Average Tensile Strength kN{kgf}	Maximum Allowable Load kN{kgf}	Approximate Mass kg/m	Number of Links Per Unit
RS37-1	-	8.14{830}	9.41{960}	1.37{140}	0.29	240
RS38-1	-	8.14{830}	9.41{960}	1.37{140}	0.35	240
RS41-1	7.4{755}	10.3{1050}	11.8{1200}	2.26{230}	0.41	240

Note: 1. Maximum allowable load when using a one-pitch offset link (OL) is 65% of the above.
2. Number of links per unit = 240

Lubrication Type Small Sprocket No. of Teeth	Small Sprocket Max rpm																									
	10	25	50	100	200	300	400	500	700	900	1000	1200	1400	1600	1800	2100	2400	2700	3000	3500	4000	5000	6000	7000	8000	
9	0.02	0.05	0.10	0.18	0.34	0.49	0.64	0.78	1.05	1.32	1.24	0.95	0.75	0.61	0.52	0.41	0.33	0.28	0.24	0.19	0.16	0.11	0.08	0.07	0.05	
10	0.03	0.06	0.11	0.20	0.38	0.55	0.71	0.87	1.18	1.48	1.46	1.11	0.88	0.72	0.60	0.48	0.39	0.33	0.28	0.22	0.18	0.13	0.10	0.08	0.06	
11	0.03	0.07	0.12	0.23	0.42	0.61	0.79	0.96	1.31	1.64	1.68	1.28	1.01	0.83	0.70	0.55	0.45	0.38	0.32	0.26	0.21	0.15	0.11	0.09	0.07	
12	0.03	0.07	0.13	0.25	0.46	0.67	0.87	1.06	1.43	1.80	1.91	1.46	1.16	0.95	0.79	0.63	0.52	0.43	0.37	0.29	0.24	0.17	0.13	0.10	0.08	
13	0.03	0.08	0.15	0.27	0.51	0.73	0.95	1.16	1.56	1.96	2.16	1.64	1.30	1.07	0.89	0.71	0.58	0.49	0.42	0.33	0.27	0.19	0.15	0.12	0.10	
14	0.04	0.08	0.16	0.29	0.55	0.79	1.02	1.25	1.69	2.12	2.34	1.84	1.46	1.19	1.00	0.79	0.65	0.54	0.46	0.37	0.30	0.22	0.16	0.13	0.11	
15	0.04	0.09	0.17	0.32	0.59	0.85	1.10	1.35	1.83	2.29	2.52	2.04	1.62	1.32	1.11	0.88	0.72	0.60	0.52	0.41	0.33	0.24	0.18	0.14	0.12	
16	0.04	0.10	0.18	0.34	0.63	0.91	1.18	1.45	1.96	2.45	2.70	2.24	1.78	1.46	1.22	0.97	0.79	0.66	0.57	0.45	0.37	0.26	0.20	0.16	0.13	
17	0.05	0.10	0.19	0.36	0.68	0.97	1.26	1.54	2.09	2.62	2.88	2.46	1.95	1.60	1.34	1.06	0.87	0.73	0.62	0.49	0.40	0.29	0.22	0.17	0.14	
18	0.05	0.11	0.21	0.39	0.72	1.04	1.34	1.64	2.22	2.79	3.06	2.68	2.12	1.74	1.46	1.16	0.95	0.79	0.68	0.54	0.44	0.31	0.24	0.19		
19	0.05	0.12	0.22	0.41	0.76	1.10	1.42	1.74	2.36	2.95	3.25	2.90	2.30	1.89	1.58	1.25	1.03	0.86	0.73	0.58	0.48	0.34	0.26	0.21		
20	0.05	0.12	0.23	0.43	0.81	1.16	1.51	1.84	2.49	3.12	3.43	3.13	2.49	2.04	1.71	1.35	1.11	0.93	0.79	0.63	0.52	0.37	0.28	0.22		
21	0.06	0.13	0.24	0.46	0.85	1.22	1.59	1.94	2.63	3.29	3.62	3.37	2.68	2.19	1.84	1.46	1.19	1.00	0.85	0.68	0.55	0.40	0.30	0.24		
22	0.06	0.14	0.26	0.48	0.89	1.29	1.67	2.04	2.76	3.46	3.81	3.62	2.87	2.35	1.97	1.56	1.28	1.07	0.91	0.73	0.59	0.43	0.32	0.26		
23	0.06	0.14	0.27	0.50	0.94	1.35	1.75	2.14	2.90	3.63	3.99	3.87	3.07	2.51	2.10	1.67	1.37	1.15	0.98	0.78	0.64	0.45	0.35	0.27		
24	0.07	0.15	0.28	0.53	0.98	1.41	1.83	2.24	3.03	3.80	4.18	4.12	3.27	2.68	2.24	1.78	1.46	1.22	1.04	0.83	0.68	0.48	0.37	0.29		
25	0.07	0.16	0.29	0.55	1.03	1.48	1.92	2.34	3.17	3.97	4.37	4.38	3.48	2.85	2.38	1.89	1.55	1.30	1.11	0.88	0.72	0.52	0.39			
26	0.07	0.16	0.31	0.57	1.07	1.54	2.00	2.44	3.31	4.15	4.56	4.65	3.69	3.02	2.53	2.01	1.64	1.38	1.18	0.93	0.76	0.55	0.42			
28	0.08	0.18	0.33	0.62	1.16	1.67	2.16	2.65	3.58	4.49	4.94	5.19	4.12	3.37	2.83	2.24	1.84	1.54	1.31	1.04	0.85	0.61	0.46			
30	0.08	0.19	0.36	0.67	1.25	1.80	2.33	2.85	3.86	4.84	5.32	5.76	4.57	3.74	3.13	2.49	2.04	1.71	1.46	1.16	0.95	0.68	0.52			
32	0.09	0.21	0.38	0.72	1.34	1.93	2.50	3.06	4.14	5.19	5.70	6.34	5.03	4.12	3.45	2.74	2.24	1.88	1.60	1.27	1.04	0.75				
35	0.10	0.23	0.42	0.79	1.48	2.13	2.75	3.37	4.56	5.72	6.28	7.26	5.76	4.71	3.95	3.13	2.57	2.15	1.84	1.46	1.19	0.85				
40	0.12	0.26	0.49	0.91	1.71	2.46	3.18	3.89	5.27	6.60	7.26	8.55	7.04	5.76	4.83	3.83	3.13	2.63	2.24	1.78	1.46	1.04				
45	0.13	0.30	0.56	1.04	1.94	2.79	3.61	4.42	5.98	7.50	8.24	9.71	8.39	6.87	5.76	4.57	3.74	3.13	2.68	2.12	1.74					

Note: 1. Please contact a Tsubaki representative prior to use of kW ratings in the colored area of the table.

Lubrication method	A	Manual lubrication or drip lubrication	Details on Pg. 193
	B	Oil bath or slinger disc lubrication	
	C	Forced pump lubrication	

Before Use
Standard Roller Chains
Lube-Free Roller Chains
Heavy Duty Roller Chains
Corrosion Resistant Roller Chains
Specialty Roller Chains
Sprockets
Pin Gear Drives
Accessories
Selection
Handling

RS35

Before Use
 Standard Roller Chains
 Lubrication
 Lubrication-Free Roller Chains
 Heavy Duty Roller Chains
 Corrosion Resistant Roller Chains
 Specialty Roller Chains
 Sprockets
 Pin Gear Drives
 Accessories
 Selection
 Handling

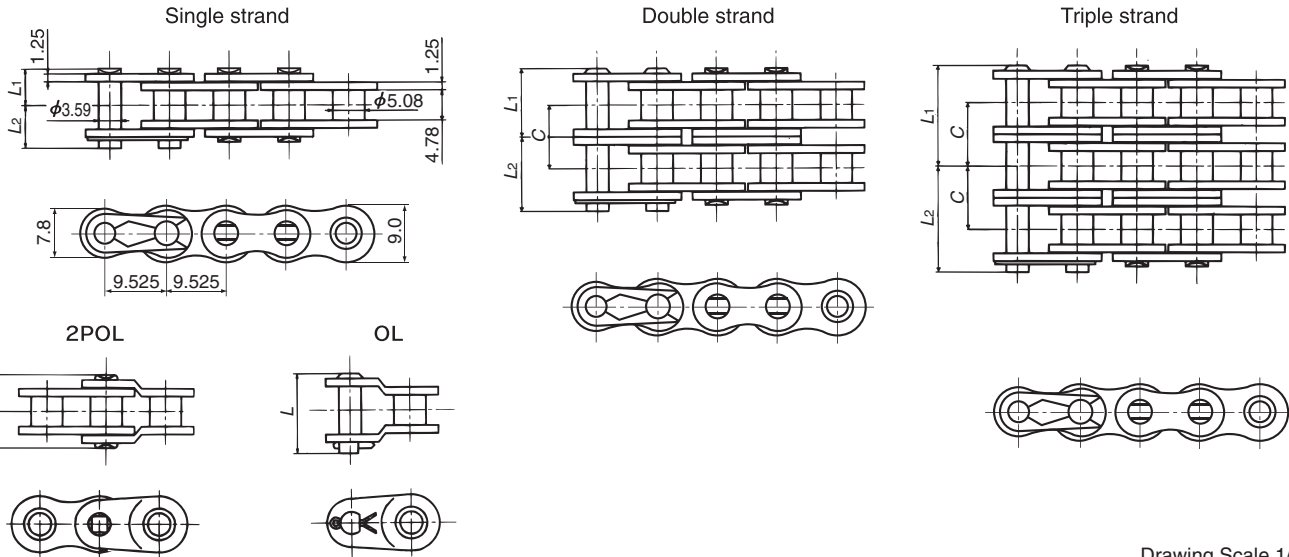

Drawing Scale 1/1.2

TSUBAKI Chain Number	Number of Strands	Pin Length L _{1+L2}	Dimensions L ₁	Dimensions L ₂	Offset Pin Length L	Transverse Pitch C	Pin Type	ANSI Standard Min. Tensile Strength kN{kgf}	Tsubaki Minimum Tensile Strength kN{kgf}	Tsubaki Average Tensile Strength kN{kgf}	Maximum Allowable Load kN{kgf}	Approximate Mass kg/m
RS35-1	1	12.7	5.85	6.85	13.5			8.7 {887}	9.81{1000}	11.3{1150}	2.16{220}	0.33
RS35-2	2	22.8	10.9	11.9	24.5	10.1	Riveting	17.4{1774}	19.6{2000}	22.6{2300}	3.63{370}	0.69
RS35-3	3	32.9	16.0	16.9	34.6			26.1{2661}	29.4{3000}	33.8{3450}	5.39{550}	1.05

Note: 1. Maximum allowable load when using a one-pitch offset link (OL) is 65% of the above.
 2. Number of links per unit = 320 3. Bushed chain.

■ RS35-1 Maximum Kilowatt Ratings Table (kW Ratings for Single Strand Chain)

Small Sprocket No. of Teeth	Small Sprocket Max rpm																								
	A					B														C					
Lubrication Type	50	100	300	500	700	900	1200	1500	1800	2100	2500	3000	3500	4000	4500	5000	5500	6000	6500	7000	7500	8000	8500	9000	10000
9	0.09	0.17	0.47	0.74	1.00	1.26	1.63	1.99	2.34	2.69	2.13	1.62	1.29	1.05	0.88	0.75	0.65	0.57	0.51	0.46	0.41	0.37	0.34	0.31	0.27
10	0.10	0.19	0.52	0.83	1.12	1.41	1.82	2.23	2.63	3.02	2.50	1.90	1.51	1.23	1.03	0.88	0.77	0.67	0.60	0.53	0.48	0.44	0.40	0.37	0.31
11	0.12	0.22	0.58	0.92	1.24	1.56	2.02	2.47	2.91	3.34	2.88	2.19	1.74	1.42	1.19	1.02	0.88	0.77	0.69	0.61	0.55	0.50	0.46	0.42	0.36
12	0.13	0.24	0.64	1.01	1.37	1.71	2.22	2.71	3.20	3.67	3.28	2.50	1.98	1.62	1.36	1.16	1.01	0.88	0.78	0.70	0.63	0.57	0.52	0.48	0.41
13	0.14	0.26	0.70	1.10	1.49	1.87	2.42	2.96	3.49	4.01	3.70	2.82	2.23	1.83	1.53	1.31	1.13	1.00	0.88	0.79	0.71	0.65	0.59	0.54	0.46
14	0.15	0.28	0.75	1.19	1.61	2.02	2.62	3.21	3.78	4.34	4.14	3.15	2.50	2.04	1.71	1.46	1.27	1.11	0.99	0.88	0.80	0.72	0.66	0.61	0.52
15	0.16	0.30	0.81	1.29	1.74	2.18	2.83	3.45	4.07	4.68	4.59	3.49	2.77	2.27	1.90	1.62	1.41	1.23	1.09	0.98	0.88	0.80	0.73	0.67	0.57
16	0.17	0.32	0.87	1.38	1.87	2.34	3.03	3.70	4.36	5.01	5.05	3.85	3.05	2.5	2.09	1.79	1.55	1.36	1.21	1.08	0.97	0.88	0.81	0.74	0.63
17	0.19	0.35	0.93	1.47	1.99	2.50	3.23	3.95	4.66	5.35	5.54	4.21	3.34	2.74	2.29	1.96	1.70	1.49	1.32	1.18	1.07	0.97	0.88	0.81	0.69
18	0.20	0.37	0.99	1.56	2.12	2.66	3.44	4.21	4.96	5.69	6.03	4.59	3.64	2.98	2.50	2.13	1.85	1.62	1.44	1.29	1.16	1.05	0.96	0.88	0.75
19	0.21	0.39	1.05	1.66	2.25	2.82	3.65	4.46	5.25	6.04	6.54	4.98	3.95	3.23	2.71	2.31	2.00	1.76	1.56	1.40	1.26	1.14	1.04	0.96	0.82
20	0.22	0.41	1.11	1.75	2.37	2.98	3.86	4.71	5.55	6.38	7.06	5.37	4.26	3.49	2.93	2.50	2.16	1.90	1.69	1.51	1.36	1.23	1.13	1.03	0.88
21	0.23	0.43	1.17	1.85	2.5	3.14	4.06	4.97	5.85	6.72	7.6	5.78	4.59	3.76	3.15	2.69	2.33	2.04	1.81	1.62	1.46	1.33	1.21	1.11	0.95
22	0.24	0.46	1.23	1.94	2.63	3.30	4.27	5.22	6.16	7.07	8.15	6.20	4.92	4.03	3.37	2.88	2.50	2.19	1.94	1.74	1.57	1.42	1.30	1.19	1.02
23	0.26	0.48	1.29	2.04	2.76	3.46	4.48	5.48	6.46	7.42	8.68	6.63	5.26	4.30	3.61	3.08	2.67	2.34	2.08	1.86	1.68	1.52	1.39	1.28	1.09
24	0.27	0.50	1.35	2.13	2.89	3.62	4.69	5.74	6.76	7.77	9.09	7.06	5.61	4.59	3.85	3.28	2.85	2.50	2.21	1.98	1.79	1.62	1.48	1.36	1.16
25	0.28	0.52	1.41	2.23	3.02	3.79	4.91	6.00	7.07	8.12	9.50	7.51	5.96	4.88	4.09	3.49	3.03	2.66	2.35	2.11	1.90	1.72	1.57	1.45	1.23
26	0.29	0.55	1.47	2.33	3.15	3.95	5.12	6.26	7.37	8.47	9.91	7.97	6.32	5.17	4.34	3.70	3.21	2.82	2.50	2.23	2.02	1.83	1.67	1.53	1.31
28	0.32	0.59	1.59	2.52	3.41	4.28	5.54	6.78	7.99	9.18	10.7	8.90	7.06	5.78	4.85	4.14	3.59	3.15	2.79	2.50	2.25	2.04	1.87	1.71	1.46
30	0.34	0.64	1.72	2.72	3.68	4.61	5.97	7.30	8.60	9.89	11.6	9.87	7.83	6.41	5.37	4.59	3.98	3.49	3.10	2.77	2.50	2.27	2.07	1.90	1.62
32	0.37	0.68	1.84	2.91	3.94	4.94	6.40	7.83	9.23	10.6	12.4	10.9	8.63	7.06	5.92	5.05	4.38	3.85	3.41	3.05	2.75	2.50	2.28	2.09	
35	0.40	0.75	2.03	3.21	4.34	5.45	7.06	8.63	10.2	11.7	13.7	12.4	9.87	8.08	6.77	5.78	5.01	4.40	3.90	3.49	3.15	2.86	2.61	2.39	
40	0.47	0.87	2.34	3.71	5.02	6.29	8.15	9.96	11.7	13.5	15.8	15.2	12.1	9.87	8.27	7.06	6.12	5.37	4.77	4.26	3.85	3.49			
45	0.53	0.99	2.66	4.21	5.70	7.14	9.26	11.3	13.3	15.3	17.9	18.1	14.4	11.8	9.87	8.43	7.31	6.41	5.69	5.09					

Note: 1. KW rating when using a one-pitch offset link (OL) is 80% of the above.
 2. Please contact a Tsubaki representative prior to use of kW ratings in the colored area of the table.

Multi-strand factor	Number of chain strands		Multi-strand factor	
	Double strand	1.7	Quintuple strand	3.9
	Triple strand	2.5	Sextuple strand	4.6
	Quadruple strand	3.3	-	-

Lubrication method	A	Manual lubrication or drip lubrication	Details on Pg. 193
	B	Oil bath or slinger disc lubrication	
	C	Forced pump lubrication	

RS35 Sprocket

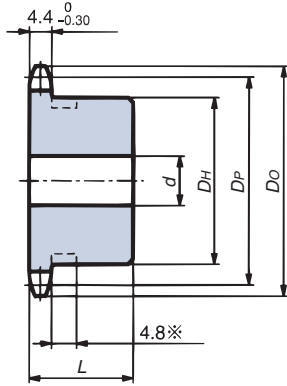

Mechanically machined (1B type)

Sprocket Number

RS35 -1B 15T

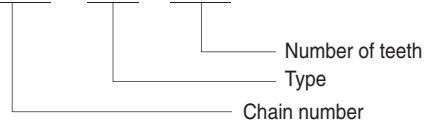

Number of Teeth	Pitch Circular Diameter (Dp)	Sprocket Outer Diameter (Do)	1B type					Material	Number of Teeth
			Bore Diameter (d)		Hub				
9	27.85	32	8	11	22	20	0.05	※	9
10	30.82	35	8	12	25	20	0.07	※	10
11	33.81	38	8	14	27	20	0.08	※	11
12	36.80	41	8	16.5	31	20	0.11	※	12
13	39.80	44	9.5	18	32	20	0.12	※	13
14	42.80	47	9.5	16.5	30	20	0.12	Mechanically machined; machine-structural carbon steel	14
15	45.81	51	9.5	19	35	20	0.16		15
16	48.82	54	9.5	20	37	20	0.18		16
17	51.84	57	9.5	24	41	20	0.22		17
18	54.85	60	9.5	24.5	44	20	0.25		18
19	57.87	63	9.5	28.5	47	20	0.29		19
20	60.89	66	9.5	30	50	20	0.32		20
21	63.91	69	9.5	32	53	20	0.36		21
22	66.93	72	9.5	32	53	20	0.37		22
23	69.95	75	9.5	32	53	20	0.38		23
24	72.97	78	9.5	32	53	22	0.43		24
25	76.00	81	12.7	32	53	22	0.43		25
26	79.02	84	12.7	32	53	22	0.44		26
27	82.05	87	12.7	32	53	22	0.45		27
28	85.07	90	12.7	32	53	22	0.47		28
30	91.12	96	12.7	32	53	22	0.50		30
32	97.18	102	12.7	32	53	22	0.53	32	
34	103.23	109	12.7	32	53	22	0.56	34	
35	106.26	112	12.7	32	53	22	0.58	35	
36	109.29	115	12.7	32	53	22	0.59	36	
38	115.34	121	13	42	63	25	0.82	38	
40	121.40	127	13	42	63	25	0.86	40	
42	127.46	133	13	42	63	25	0.90	42	
45	136.55	142	13	42	63	25	0.96	45	
48	145.64	151	13	42	63	25	1.0	48	
50	151.69	157	13	42	63	25	1.1	50	
54	163.82	169	13	42	63	25	1.2	54	
60	182.00	187	13	42	63	25	1.4	60	
65	197.15	203	16	45	68	25	1.6	65	
70	212.30	218	16	45	68	25	1.7	70	
75	227.46	233	16	45	68	25	1.9	75	



Example of grooved sprocket

- Note: 1. Maximum bore diameter is the typical range. Determine bore diameter and key bearing pressure based on general mechanical design.
 2. Models in shaded areas have hardened teeth.
 3. Sprockets marked with an * have an outer groove around the hub. Groove outer diameter is 16 for 9T, 22 for 10T, 24 for 12T and 28 for 13T.
 4. Sprockets with 42 or more teeth do not have hardened teeth, but the Strong Series of sprocket with hardened teeth can be made-to-order.

RS40

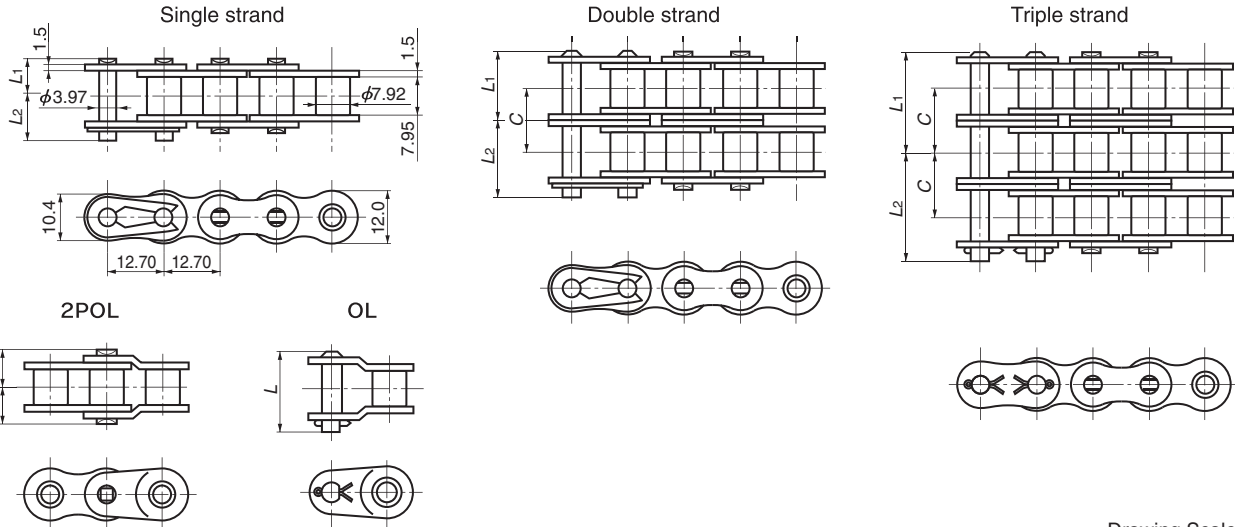

Drawing Scale 1/1.6

TSUBAKI Chain Number	Number of Strands	Pin Length L ₁ +L ₂	Dimensions L ₁	Dimensions L ₂	Offset Pin Length L	Transverse Pitch C	Pin Type	ANSI Standard Min. Tensile Strength kN{kgf}	Tsubaki Minimum Tensile Strength kN{kgf}	Tsubaki Average Tensile Strength kN{kgf}	Maximum Allowable Load kN{kgf}	Approximate Mass kg/m
RS40-1	1	18.2	8.25	9.95	18.2	14.4	Riveting	15.2 {1550}	17.7 {1800}	19.1 {1950}	3.63 {370}	0.64
RS40-2	2	32.6	15.45	17.15	33.5			30.4 {3100}	35.3 {3600}	38.2 {3900}	6.18 {630}	1.27
RS40-3	3	46.8	22.65	24.15	47.9			45.6 {4650}	53.0 {5400}	57.4 {5850}	9.12 {930}	1.90
RS40-4	4	61.2	29.9	31.3	62.3			-	70.6 {7200}	76.5 {7800}	12.0 {1220}	2.53
RS40-5	5	75.7	37.1	38.6	76.8			-	88.3 {9000}	95.6 {9750}	14.1 {1440}	3.16
RS40-6	6	90.1	44.3	45.8	91.2			-	106 {10800}	115 {11700}	16.7 {1700}	3.79

Note: 1. Maximum allowable load when using a one-pitch offset link (OL) is 65% of the above. Two pitch offset links (2POL) can be used at 100% of the above values.
 2. Number of links per unit = 240

■ RS40-1 Maximum Kilowatt Ratings Table (kW Ratings for Single Strand Chain)

Small Sprocket No. of Teeth	Small Sprocket Max rpm																								
	10	25	50	100	200	300	400	500	700	900	1000	1200	1400	1600	1800	2100	2400	2700	3000	3500	4000	5000	6000	7000	8000
	A										B										C				
9	0.07	0.15	0.28	0.52	0.97	1.40	1.81	2.21	3.00	3.75	3.75	3.75	3.75	3.07	2.58	2.04	1.67	1.40	1.20	0.95	0.78	0.56	0.42	0.34	0.27
10	0.07	0.17	0.31	0.58	1.09	1.57	2.03	2.48	3.36	4.21	4.40	4.40	4.40	3.60	3.02	2.39	1.96	1.64	1.40	1.11	0.91	0.65	0.50	0.39	0.32
11	0.08	0.19	0.35	0.65	1.21	1.74	2.25	2.75	3.72	4.67	5.07	5.07	5.07	4.15	3.48	2.76	2.26	1.89	1.62	1.28	1.05	0.75	0.57	0.45	0.37
12	0.09	0.20	0.38	0.71	1.32	1.91	2.47	3.02	4.09	5.13	5.64	5.67	5.67	4.73	3.97	3.15	2.58	2.16	1.84	1.46	1.20	0.86	0.65	0.52	0.42
13	0.10	0.22	0.41	0.77	1.44	2.08	2.69	3.29	4.46	5.59	6.15	6.18	6.18	5.34	4.47	3.55	2.90	2.43	2.08	1.65	1.35	0.97	0.73	0.58	0.48
14	0.11	0.24	0.45	0.84	1.56	2.25	2.92	3.57	4.83	6.06	6.66	6.70	6.70	5.96	5.00	3.97	3.25	2.72	2.32	1.84	1.51	1.08	0.82	0.65	0.53
15	0.11	0.26	0.48	0.90	1.69	2.43	3.14	3.84	5.20	6.52	7.17	7.21	7.21	6.61	5.54	4.40	3.60	3.02	2.58	2.04	1.67	1.20	0.91	0.72	0.59
16	0.12	0.28	0.52	0.97	1.81	2.60	3.37	4.12	5.58	7.00	7.69	7.74	7.74	7.28	6.10	4.84	3.97	3.32	2.84	2.25	1.84	1.32	1.00	0.80	0.65
17	0.13	0.30	0.55	1.03	1.93	2.78	3.60	4.40	5.96	7.47	8.21	8.26	8.26	7.98	6.69	5.31	4.34	3.64	3.11	2.47	2.02	1.44	1.10	0.87	0.71
18	0.14	0.32	0.59	1.10	2.05	2.96	3.83	4.68	6.34	7.94	8.73	8.79	8.79	8.69	7.28	5.78	4.73	3.97	3.39	2.69	2.20	1.57	1.20	0.95	
19	0.15	0.33	0.62	1.17	2.18	3.13	4.06	4.96	6.72	8.42	9.26	9.43	9.43	9.43	7.90	6.27	5.13	4.30	3.67	2.91	2.38	1.71	1.30	1.03	
20	0.16	0.35	0.66	1.23	2.30	3.31	4.29	5.24	7.10	8.90	9.79	10.2	10.2	10.2	8.53	6.77	5.54	4.64	3.97	3.15	2.58	1.84	1.40	1.11	
21	0.16	0.37	0.70	1.30	2.42	3.49	4.52	5.53	7.48	9.38	10.3	11.0	11.0	11.0	9.18	7.28	5.96	5.00	4.27	3.39	2.77	1.98	1.51	1.20	
22	0.17	0.39	0.73	1.37	2.55	3.67	4.76	5.81	7.87	9.87	10.8	11.7	11.7	11.7	9.84	7.81	6.39	5.36	4.57	3.63	2.97	2.13	1.62	1.28	
23	0.18	0.41	0.77	1.43	2.67	3.85	4.99	6.10	8.26	10.4	11.4	12.6	12.6	12.6	10.5	8.35	6.83	5.73	4.89	3.88	3.18	2.27	1.73	1.37	
24	0.19	0.43	0.80	1.50	2.80	4.03	5.22	6.39	8.65	10.8	11.9	13.4	13.4	13.4	11.2	8.90	7.28	6.10	5.21	4.14	3.39	2.42	1.84	1.46	
25	0.20	0.45	0.84	1.57	2.93	4.21	5.46	6.67	9.03	11.3	12.5	14.1	14.1	14.1	11.9	9.46	7.74	6.49	5.54	4.40	3.60	2.58	1.96		
26	0.21	0.47	0.88	1.64	3.05	4.40	5.70	6.96	9.43	11.8	13.0	14.7	14.7	14.7	12.6	10.0	8.21	6.88	5.88	4.66	3.82	2.73	2.08		
28	0.22	0.51	0.95	1.77	3.31	4.76	6.17	7.54	10.2	12.8	14.1	16.0	16.0	16.0	14.1	11.2	9.18	7.69	6.57	5.21	4.27	3.05	2.32		
30	0.24	0.55	1.02	1.91	3.56	5.13	6.65	8.13	11.0	13.8	15.2	17.2	17.2	17.2	15.7	12.4	10.2	8.53	7.28	5.78	4.73	3.39	2.58		
32	0.26	0.59	1.10	2.05	3.82	5.50	7.13	8.71	11.8	14.8	16.3	18.4	18.4	18.4	17.3	13.7	11.2	9.40	8.03	6.37	5.21	3.73			
35	0.28	0.65	1.21	2.26	4.21	6.06	7.85	9.60	13.0	16.3	17.9	20.3	20.3	20.3	19.8	15.7	12.8	10.8	9.18	7.28	5.96	4.27			
40	0.33	0.75	1.40	2.60	4.86	7.00	9.07	11.1	15.0	18.8	20.7	24.1	24.1	24.1	24.1	24.1	19.2	15.7	13.1	11.2	8.90	7.28	5.21		
45	0.37	0.85	1.59	2.96	5.52	7.95	10.3	12.6	17.0	21.4	23.5	27.7	28.8	28.8	28.8	22.9	18.7	15.7	13.4	10.6	8.69				

Note: 1. KW rating when using a one-pitch offset link (OL) is 80% of the above. Two pitch offset links (2POL) can be used at 100% of the above values.
 2. Please contact a Tsubaki representative prior to use of kW ratings in the colored area of the table.

Multi-strand factor	Number of chain strands	Multi-strand factor	Number of chain strands	Multi-strand factor
	Double strand	1.7	Quintuple strand	3.9
	Triple strand	2.5	Sextuple strand	4.6
	Quadruple strand	3.3	-	-

Lubrication method	A	Manual lubrication or drip lubrication	Details on Pg. 193
	B	Oil bath or slinger disc lubrication	
	C	Forced pump lubrication	

Before Use | Standard Roller Chains | Lubrication-Free Roller Chains | Heavy Duty Roller Chains | Corrosion Resistant Roller Chains | Specialty Roller Chains | Sprockets | Pin Gear Drives | Accessories | Selection | Handling

RS40 Sprocket

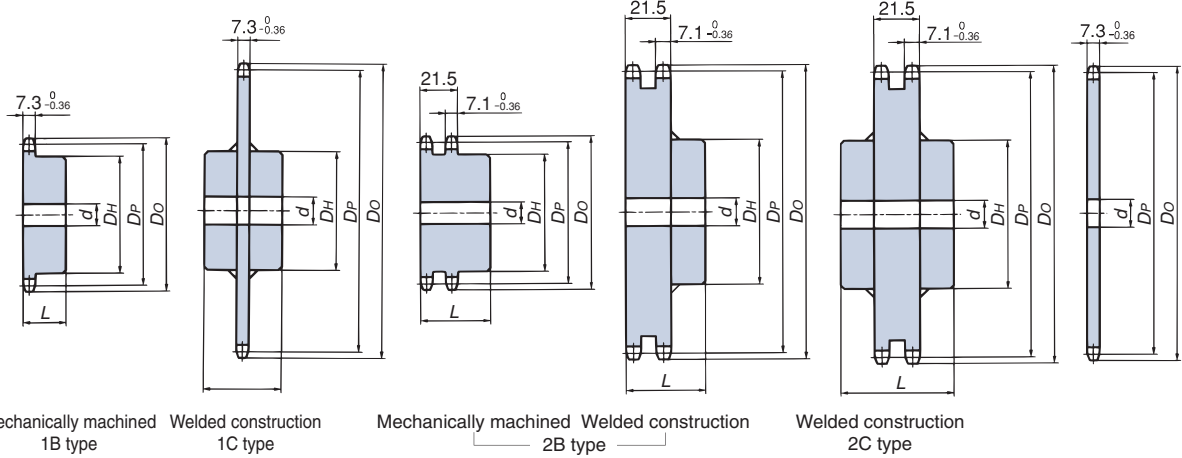

Mechanically machined 1B type Welded construction 1C type Mechanically machined 2B type Welded construction 2B type Welded construction 2C type

Number of Teeth	Pitch Circular Diameter (D _p)	Sprocket Outer Diameter (D _o)	1B type						1C type				2B type						2C type						1A type		Number of Teeth	
			Bore Diameter (d)	Max. Bore Diameter	Hub Diameter (D _H)	Hub Length (L)	Approx. Mass (kg)	Material	Bore Diameter (d)	Hub Diameter (D _H)	Hub Length (L)	Approx. Mass (kg)	Material	Bore Diameter (d)	Max. Bore Diameter	Hub Diameter (D _H)	Hub Length (L)	Approx. Mass (kg)	Material	Bore Diameter (d)	Max. Bore Diameter	Hub Diameter (D _H)	Hub Length (L)	Approx. Mass (kg)	Material	Pin Bore Diameter		Approx. Mass (kg)
9	37.13	43																									9.5	
10	41.10	47	9.5	16.5	32	22	0.13	*	*	*																		10
11	45.08	51	9.5	20	37	22	0.17	*	*	*																		11
12	49.07	55	9.5	22	40	22	0.21	*	*	*																		12
13	53.07	59	9.5	20	37	22	0.22	*	*	*																		13
14	57.07	63	9.5	24	42	22	0.28																					14
15	61.08	67	9.5	28.5	46	22	0.33																					15
16	65.10	71	12.7	30	50	22	0.37																					16
17	69.12	76	12.7	32	54	22	0.44																					17
18	73.14	80	12.7	35	57	22	0.49																					18
19	77.16	84	12.7	39.5	62	22	0.57																					19
20	81.18	88	12.7	45.5	67	25	0.73																					20
21	85.21	92	12.7	45.5	71	25	0.82																					21
22	89.24	96	12.7	50	75	25	0.91																					22
23	93.27	100	12.7	50	77	25	0.98																					23
24	97.30	104	12.7	42	63	25	0.80																					24
25	101.33	108	12.7	42	63	25	0.83																					25
26	105.36	112	12.7	42	63	25	0.87																					26
27	109.40	116	12.7	42	63	25	0.91																					27
28	113.43	120	12.7	42	63	25	0.95																					28
30	121.50	128	12.7	42	63	25	1.0																					30
32	129.57	137	16	45	68	28	1.3																					32
34	137.64	145	16	45	68	28	1.4																					34
35	141.68	149	16	45	68	28	1.4																					35
36	145.72	153	16	45	68	28	1.5																					36
38	153.79	161	16	45	68	28	1.6																					38
40	161.87	169	16	45	68	28	1.7																					40
42	169.94	177	18	48	73	32	2.0																					42
45	182.06	189	18	48	73	32	2.2																					45
48	194.18	201	18	48	73	32	2.4																					48
50	202.26	209	18	48	73	32	2.5																					50
54	218.42	226	18	48	73	32	2.8																					54
60	242.66	250	18	48	73	32	3.3																					60
65	262.87	270	23	55	83	32	4.0																					65
70	283.07	290	23	55	83	32	4.5																					70
75	303.28	311	23	55	83	32	5.0																					75

- Note: 1. Maximum bore diameter is the typical range. Determine bore diameter and key bearing pressure based on general mechanical design.
- 2. Models in shaded areas have hardened teeth.
- 3. The outer diameters above are given for the 1B type. Diameters vary slightly for all other types.
- 4. 1B-type sprockets marked with * have an outer groove around the hub. Groove outer diameter is 21 for 9T, 25 for 10T, 30 for 11T and 32 for 12T.
- 5. For single-strand sprockets without hardened teeth, the Strong Series of sprocket with hardened teeth can be made-to-order.
- 6. Welded specification: machine-structural carbon steel (teeth) and structural rolled steel (hub)

Sprocket Number

RS40 -2B 15T

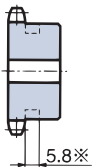

RS50

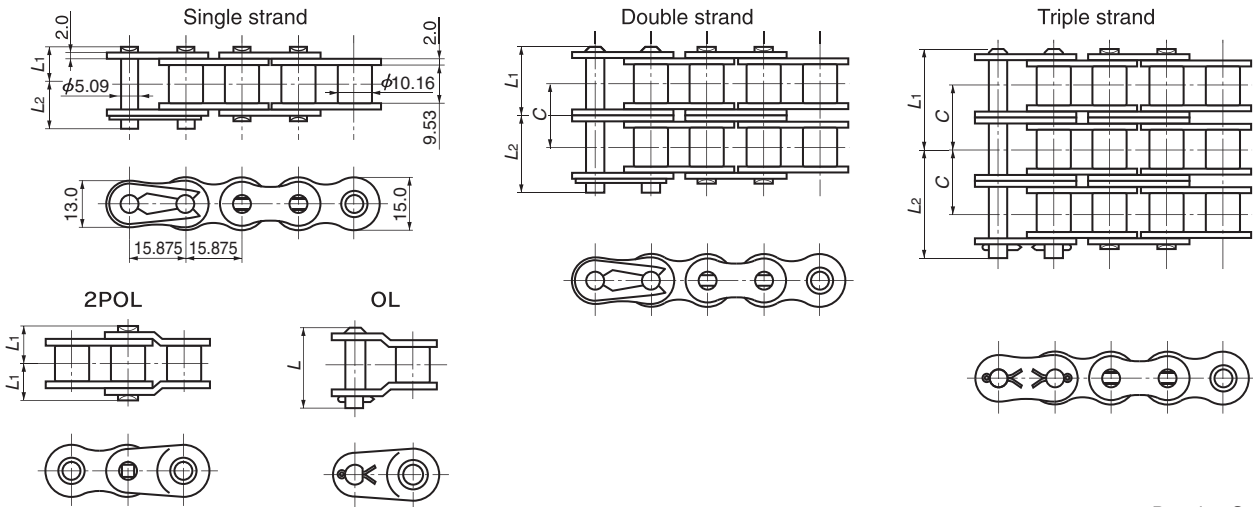

Drawing Scale 1/2

TSUBAKI Chain Number	Number of Strands	Pin Length L ₁ +L ₂	Dimensions L ₁	Dimensions L ₂	Offset Pin Length L	Transverse Pitch C	Pin Type	ANSI Standard Min. Tensile Strength kN{kgf}	Tsubaki Minimum Tensile Strength kN{kgf}	Tsubaki Average Tensile Strength kN{kgf}	Maximum Allowable Load kN{kgf}	Approximate Mass kg/m
RS50-1	1	22.2	10.3	11.9	22.6	18.1	Riveting	24 {2447}	28.4 {2900}	31.4 {3200}	6.37{650}	1.04
RS50-2	2	40.5	19.35	21.15	41.8			48 {4895}	56.9 {5800}	62.8 {6400}	10.7{1100}	2.07
RS50-3	3	58.6	28.4	30.2	59.9			72 {7342}	85.3 {8700}	94.1 {9600}	16.0{1630}	3.09
RS50-4	4	76.7	37.45	39.25	78.1			-	114 {11600}	126 {12800}	21.1{2150}	4.11
RS50-5	5	94.8	46.5	48.3	96.2			-	142 {14500}	157 {16000}	24.9{2540}	5.14
RS50-6	6	113.0	55.6	57.4	114.4			-	171 {17400}	188 {19200}	29.3{2990}	6.16

Note: 1. Maximum allowable load when using a one-pitch offset link (OL) is 65% of the above. Two pitch offset links (2POL) can be used at 100% of the above values.
2. Number of links per unit = 192

■ RS50-1 Maximum Kilowatt Ratings Table (kW Ratings for Single Strand Chain)

Small Sprocket No. of Teeth	Small Sprocket Max rpm																											
	A							B														C						
	10	25	50	100	200	300	400	500	700	900	1000	1200	1400	1600	1800	2100	2400	2700	3000	3500	4000	4500	5000	5500	6000			
9	0.14	0.33	0.61	1.14	2.13	3.07	3.97	4.86	6.35	6.35	6.35	5.66	4.49	3.67	3.08	2.44	2.00	1.68	1.43	1.14	0.93	0.78	0.67	0.58	0.51			
10	0.16	0.37	0.69	1.28	2.39	3.44	4.45	5.44	7.11	7.11	7.11	6.62	5.26	4.30	3.61	2.86	2.34	1.96	1.68	1.33	1.09	0.91	0.78	0.68	0.59			
11	0.18	0.41	0.76	1.42	2.64	3.81	4.93	6.03	7.88	7.88	7.88	7.64	6.07	4.96	4.16	3.30	2.70	2.26	1.93	1.53	1.26	1.05	0.90	0.78	0.68			
12	0.20	0.45	0.83	1.56	2.90	4.18	5.42	6.63	8.71	8.71	8.71	8.71	6.91	5.66	4.74	3.76	3.08	2.58	2.20	1.75	1.43	1.20	1.02	0.89	0.78			
13	0.21	0.49	0.91	1.70	3.17	4.56	5.91	7.22	9.78	9.82	9.82	9.82	7.79	6.38	5.34	4.24	3.47	2.91	2.48	1.97	1.61	1.35	1.15	1.00				
14	0.23	0.53	0.99	1.84	3.43	4.94	6.40	7.83	10.6	11.0	11.0	11.0	8.71	7.13	5.97	4.74	3.88	3.25	2.78	2.20	1.80	1.51	1.29	1.12				
15	0.25	0.57	1.06	1.98	3.70	5.32	6.90	8.43	11.4	12.2	12.2	12.2	9.66	7.90	6.62	5.26	4.30	3.61	3.08	2.44	2.00	1.68	1.43	1.24				
16	0.27	0.61	1.14	2.12	3.96	5.71	7.40	9.04	12.2	13.4	13.4	13.4	10.6	8.71	7.30	5.79	4.74	3.97	3.39	2.69	2.20	1.85	1.58	1.37				
17	0.29	0.65	1.22	2.27	4.23	6.10	7.90	9.65	13.1	14.7	14.7	14.7	11.7	9.54	7.99	6.34	5.19	4.35	3.71	2.95	2.41	2.02	1.73	1.50				
18	0.30	0.69	1.29	2.41	4.50	6.48	8.40	10.3	13.9	15.8	15.8	15.8	12.7	10.4	8.71	6.91	5.66	4.74	4.05	3.21	2.63	2.20	1.88					
19	0.32	0.73	1.37	2.56	4.77	6.87	8.90	10.9	14.7	16.8	16.8	16.8	13.8	11.3	9.44	7.49	6.13	5.14	4.39	3.48	2.85	2.39	2.04					
20	0.34	0.78	1.45	2.70	5.04	7.26	9.41	11.5	15.6	17.7	17.7	17.7	14.9	12.2	10.2	8.09	6.62	5.55	4.74	3.76	3.08	2.58	2.20					
21	0.36	0.82	1.53	2.85	5.32	7.66	9.92	12.1	16.4	18.7	18.7	18.7	16.0	13.1	11.0	8.71	7.13	5.97	5.10	4.05	3.31	2.78	2.37					
22	0.38	0.86	1.61	3.00	5.59	8.05	10.4	12.8	17.3	19.6	19.6	19.6	17.2	14.0	11.8	9.34	7.64	6.41	5.47	4.34	3.55	2.98	2.54					
23	0.40	0.90	1.68	3.14	5.87	8.45	10.9	13.4	18.1	20.6	20.6	20.6	18.3	15.0	12.6	9.98	8.17	6.85	5.85	4.64	3.80	3.18						
24	0.41	0.95	1.76	3.29	6.14	8.85	11.5	14.0	19.0	21.6	21.6	21.6	19.5	16.0	13.4	10.6	8.71	7.30	6.23	4.94	4.05	3.39						
25	0.43	0.99	1.84	3.44	6.42	9.24	12.0	14.6	19.8	22.5	22.5	22.5	20.8	17.0	14.3	11.3	9.26	7.76	6.62	5.26	4.30	3.61						
26	0.45	1.03	1.92	3.59	6.70	9.64	12.5	15.3	20.7	23.5	23.5	23.5	22.0	18.0	15.1	12.0	9.82	8.23	7.03	5.58	4.56	3.82						
28	0.49	1.12	2.08	3.89	7.25	10.4	13.5	16.5	22.4	25.5	25.5	25.5	24.6	20.2	16.9	13.4	11.0	9.20	7.85	6.23	5.10	4.27						
30	0.53	1.20	2.24	4.19	7.81	11.3	14.6	17.8	24.1	27.5	27.5	27.5	27.3	22.4	18.7	14.9	12.2	10.2	8.71	6.91	5.66							
32	0.57	1.29	2.41	4.49	8.38	12.1	15.6	19.1	25.9	30.1	30.1	30.1	30.1	24.6	20.6	16.4	13.4	11.2	9.59	7.61	6.23							
35	0.62	1.42	2.65	4.95	9.23	13.3	17.2	21.1	28.5	34.4	34.4	34.4	34.4	28.2	23.6	18.7	15.3	12.9	11.0	8.71	7.13							
40	0.72	1.64	3.06	5.71	10.7	15.4	19.9	24.3	32.9	41.3	42.1	42.1	42.1	34.4	28.8	22.9	18.7	15.7	13.4	10.6								
45	0.82	1.86	3.48	6.49	12.1	17.4	22.6	27.6	37.4	46.9	48.9	48.9	48.9	41.1	34.4	27.3	22.4	18.7	16.0									

Note: 1. KW rating when using a one-pitch offset link (OL) is 80% of the above. Two pitch offset links (2POL) can be used at 100% of the above values.
2. Please contact a Tsubaki representative prior to use of kW ratings in the colored area of the table.

Multi-strand factor	Number of chain strands	Multi-strand factor	Number of chain strands	Multi-strand factor
	Double strand	1.7	Quintuple strand	3.9
	Triple strand	2.5	Sextuple strand	4.6
	Quadruple strand	3.3	-	-

Lubrication method	A	Manual lubrication or drip lubrication	Details on Pg. 193
	B	Oil bath or slinger disc lubrication	
	C	Forced pump lubrication	

RS60

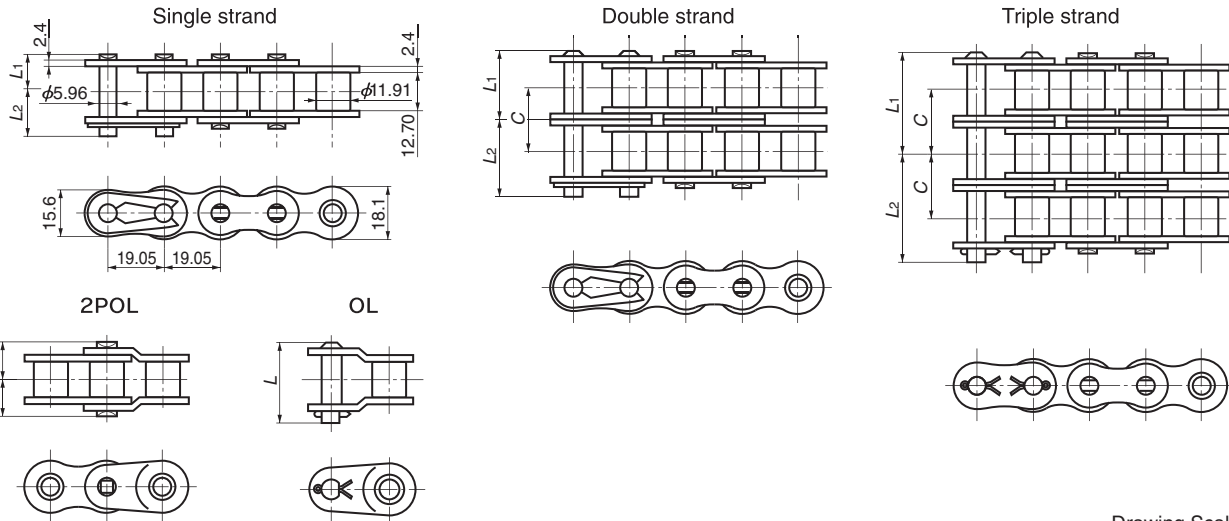

Drawing Scale 1/2.4

TSUBAKI Chain Number	Number of Strands	Pin Length L ₁ +L ₂	Dimensions L ₁	Dimensions L ₂	Offset Pin Length L	Transverse Pitch C	Pin Type	ANSI Standard Min. Tensile Strength kN{kgf}	Tsubaki Minimum Tensile Strength kN{kgf}	Tsubaki Average Tensile Strength kN{kgf}	Maximum Allowable Load kN{kgf}	Approximate Mass kg/m
RS60-1	1	27.6	12.85	14.75	28.2	22.8	Riveting Cotter pin	34.2 {3487}	40.2 {4100}	44.1 {4500}	8.83 {900}	1.53
RS60-2	2	50.5	24.25	26.25	52.6		Riveting	68.4 {6975}	80.4 {8200}	88.3 {9000}	15.0 {1530}	3.04
RS60-3	3	73.8	35.65	38.15	75.5			102.6{10462}	121 {12300}	132 {13500}	22.1 {2250}	4.54
RS60-4	4	96.6	47.05	49.55	98.3			-	161 {16400}	177 {18000}	29.1 {2970}	6.04
RS60-5	5	119.5	58.5	61.0	121.2			-	201 {20500}	221 {22500}	34.4 {3510}	7.54
RS60-6	6	142.4	69.9	72.5	144.0			-	241 {24600}	265 {27000}	40.6 {4140}	9.05

Note: 1. Maximum allowable load when using a one-pitch offset link (OL) is 65% of the above. Two pitch offset links (2POL) can be used at 100% of the above values.
2. Number of links per unit = 160

RS60-1 Maximum Kilowatt Ratings Table (kW Ratings for Single Strand Chain)

Small Sprocket No. of Teeth	Lubrication Type	Small Sprocket Max rpm																											
		A							B													C							
		10	25	50	100	150	200	300	400	500	600	700	800	900	1000	1100	1200	1400	1600	1800	2000	2500	3000	3500	4000	4500			
9		0.24	0.55	1.02	1.90	2.73	3.54	5.10	6.61	8.08	9.52	10.1	10.1	10.1	8.6	7.46	6.54	5.19	4.25	3.56	3.04	2.18	1.66	1.31	1.08	0.90			
10		0.27	0.61	1.14	2.13	3.06	3.97	5.72	7.41	9.05	10.7	11.4	11.4	11.4	10.1	8.73	7.66	6.08	4.98	4.17	3.56	2.55	1.94	1.54	1.26	1.06			
11		0.30	0.68	1.26	2.36	3.40	4.40	6.34	8.21	10.0	11.8	12.7	12.7	12.7	11.6	10.1	8.84	7.02	5.74	4.81	4.11	2.94	2.24	1.78	1.45	1.22			
12		0.33	0.74	1.39	2.59	3.73	4.83	6.96	9.02	11.0	13.0	13.9	13.9	13.9	13.2	11.5	10.1	8.00	6.54	5.48	4.68	3.35	2.55	2.02	1.66	1.39			
13		0.36	0.81	1.51	2.82	4.07	5.27	7.59	9.83	12.0	14.2	15.2	15.2	15.2	14.9	12.9	11.4	9.02	7.38	6.18	5.28	3.78	2.87	2.28	1.87				
14		0.39	0.88	1.64	3.06	4.41	5.71	8.22	10.7	13.0	15.3	16.7	16.7	16.7	14.5	12.7	10.1	8.25	6.91	5.90	4.22	3.21	2.55	2.09					
15		0.41	0.95	1.77	3.30	4.75	6.15	8.86	11.5	14.0	16.5	18.5	18.5	18.5	16.0	14.1	11.2	9.15	7.66	6.54	4.68	3.56	2.83	2.31					
16		0.44	1.01	1.89	3.53	5.09	6.59	9.50	12.3	15.0	17.7	20.4	20.4	20.4	17.7	15.5	12.3	10.1	8.44	7.21	5.16	3.92	3.11	2.55					
17		0.47	1.08	2.02	3.77	5.43	7.04	10.1	13.1	16.1	18.9	21.7	22.3	22.3	19.4	17.0	13.5	11.0	9.25	7.90	5.65	4.30	3.41	2.79					
18		0.51	1.15	2.15	4.01	5.78	7.49	10.8	14.0	17.1	20.1	23.1	23.7	23.7	21.1	18.5	14.7	12.0	10.1	8.60	6.16	4.68	3.72	3.04					
19		0.54	1.22	2.28	4.25	6.13	7.94	11.4	14.8	18.1	21.3	24.5	25.1	25.1	22.9	20.1	15.9	13.0	10.9	9.33	6.68	5.08	4.03	3.30					
20		0.57	1.29	2.41	4.50	6.48	8.39	12.1	15.7	19.1	22.6	25.9	26.6	26.6	24.7	21.7	17.2	14.1	11.8	10.1	7.21	5.48	4.35						
21		0.60	1.36	2.54	4.74	6.83	8.84	12.7	16.5	20.2	23.8	27.3	28.0	28.0	26.6	23.3	18.5	15.2	12.7	10.8	7.76	5.90	4.68						
22		0.63	1.43	2.67	4.98	7.18	9.30	13.4	17.4	21.2	25.0	28.7	29.5	29.5	28.5	25.0	19.8	16.2	13.6	11.6	8.32	6.33	5.02						
23		0.66	1.50	2.80	5.23	7.53	9.76	14.1	18.2	22.3	26.2	30.1	30.9	30.9	30.5	26.7	21.2	17.4	14.6	12.4	8.89	6.76	5.37						
24		0.69	1.57	2.93	5.47	7.89	10.2	14.7	19.1	23.3	27.5	31.5	32.5	32.5	32.5	28.5	22.6	18.5	15.5	13.2	9.48	7.21	5.72						
25		0.72	1.64	3.07	5.72	8.24	10.7	15.4	19.9	24.4	28.7	33.0	34.5	34.5	34.5	30.3	24.0	19.7	16.5	14.1	10.1	7.66	6.08						
26		0.75	1.71	3.20	5.97	8.60	11.1	16.0	20.8	25.4	29.9	34.4	36.6	36.6	36.6	32.1	25.5	20.9	17.5	14.9	10.7	8.13	6.45						
28		0.81	1.86	3.47	6.47	9.31	12.1	17.4	22.5	27.5	32.4	37.3	40.9	40.9	40.9	35.9	28.5	23.3	19.5	16.7	11.9	9.09							
30		0.88	2.00	3.73	6.97	10.0	13.0	18.7	24.3	29.7	34.9	40.1	44.9	44.9	44.9	44.9	39.8	31.6	25.9	21.7	18.5	13.2	10.1						
32		0.94	2.14	4.00	7.47	10.8	13.9	20.1	26.0	31.8	37.5	43.0	48.1	48.1	48.1	48.1	43.9	34.8	28.5	23.9	20.4	14.6	11.1						
35		1.04	2.36	4.41	8.23	11.9	15.4	22.1	28.7	35.0	41.3	47.4	53.0	53.0	53.0	53.0	50.2	39.8	32.6	27.3	23.3	16.7	12.7						
40		1.20	2.73	5.09	9.50	13.7	17.7	25.5	33.1	40.5	47.7	54.8	61.3	61.3	61.3	61.3	61.3	48.7	39.8	33.4	28.5	20.4							
45		1.36	3.10	5.78	10.8	15.5	20.1	29.0	37.6	45.9	54.1	62.2	70.1	73.2	73.2	73.2	73.2	58.1	47.5	39.8	34.0	24.3							

Note: 1. KW rating when using a one-pitch offset link (OL) is 80% of the above. Two pitch offset links (2POL) can be used at 100% of the above values.
2. Please contact a Tsubaki representative prior to use of kW ratings in the colored area of the table.

Multi-strand factor	Number of chain strands	Multi-strand factor	Number of chain strands	Multi-strand factor	Lubrication method	A	Manual lubrication or drip lubrication	Details on Pg. 193
	Double strand	1.7	Quintuple strand	3.9		B	Oil bath or slinger disc lubrication	
	Triple strand	2.5	Sextuple strand	4.6		C	Forced pump lubrication	
	Quadruple strand	3.3	-	-				

RS60 Sprocket

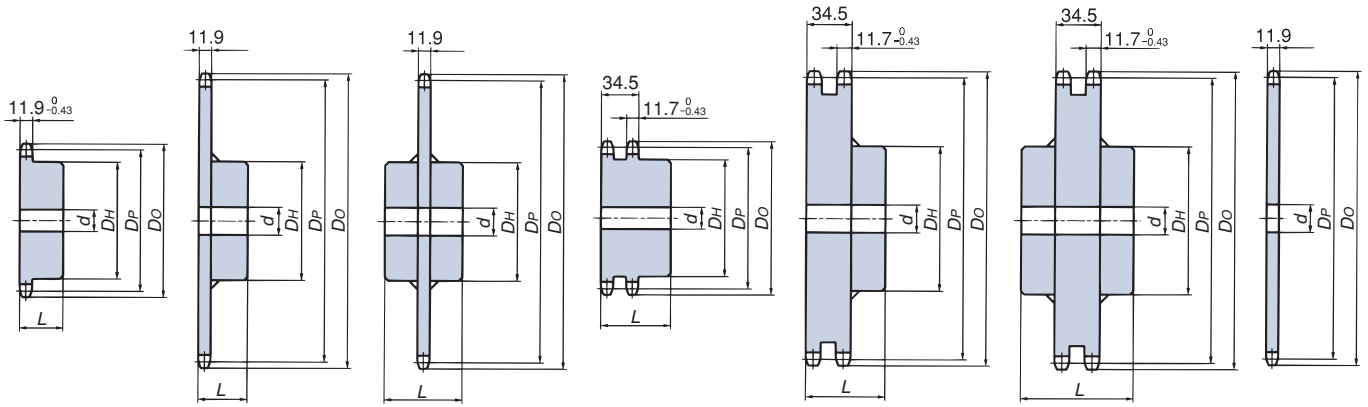

Mechanically machined 1B type, Welded construction 1B type, Welded construction 1C type, Mechanically machined 2B type, Welded construction 2B type, Welded construction 2C type, 1A type

Number of Teeth	Pitch Circular Diameter (D _p)	1B type							1C type				2B type				2C type				1A type			Number of Teeth	
		Sprocket Outer Diameter (D _o)	Bore Diameter (d)		Hub		Approx. Mass (kg)	Material	Pilot Bore Diameter	Maximum	Diameter (D _H)	Length (L)	Approx. Mass (kg)	Material	Pilot Bore Diameter	Maximum	Diameter (D _H)	Length (L)	Approx. Mass (kg)	Material	Pilot Bore Diameter	Approx. Mass (kg)	Material		
9	55.70	64	9.5	24.5	43	32	0.36	※																	9
10	61.65	70	12.7	30	49	32	0.45	※																	10
11	67.62	76	12.7	32	51	32	0.55	※																	11
12	73.60	83	12.7	32	51	32	0.63																		12
13	79.60	89	15.9	35	57	32	0.76																		13
14	85.61	95	15.9	39.5	62	32	0.90																		14
15	91.63	101	15.9	45.5	68	32	1.1																		15
16	97.65	107	15.9	47.5	73	32	1.2																		16
17	103.67	113	15.9	47.5	73	32	1.3																		17
18	109.70	119	15.9	55	83	40	1.9																		18
19	115.74	126	15.9	55	83	40	2.0																		19
20	121.78	132	15.9	55	83	40	2.1																		20
21	127.82	138	15.9	55	83	40	2.2																		21
22	133.86	144	15.9	55	83	40	2.3																		22
23	139.90	150	18	55	83	40	2.4																		23
24	145.95	156	18	55	83	40	2.6																		24
25	151.99	162	18	55	83	40	2.7																		25
26	158.04	168	18	55	83	40	2.8																		26
27	164.09	174	18	55	83	40	3.0																		27
28	170.14	181	18	55	83	40	3.1																		28
30	182.25	193	18	55	83	40	3.4																		30
32	194.35	205	18	55	83	40	3.8																		32
34	206.46	217	18	55	83	40	4.1																		34
35	212.52	223	18	55	83	40	4.3																		35
36	218.57	229	18	55	83	40	4.5																		36
38	230.69	241	18	55	83	40	4.9																		38
40	242.80	253	18	55	83	40	5.3																		40
42	254.92	266	23	63	93	45	6.2																		42
45	273.09	284	23	63	93	45	6.9																		45
48	291.27	302	23	63	93	45	7.6																		48
50	303.39	314	23	63	93	45	8.2																		50
54	327.63	338	23	63	93	45	9.3																		54
60	363.99	375	23	63	93	45	11.1																		60
65	394.30	405	28	75	107	45	13.2																		65
70	424.61	436	28	75	107	45	15.0																		70
75	454.92	466	28	75	107	45	16.9																		75

- Note: 1. Maximum bore diameter is the typical range. Determine bore diameter and key bearing pressure based on general mechanical design.
 2. Models in shaded areas have hardened teeth.
 3. Outer diameters above are given for the 1B type. Diameters vary slightly for all other types.
 4. 1B-type sprockets marked with an * have an outer groove around the hub. Groove outer diameter is 32 for 9T, 37 for 10T and 45 for 11T.
 5. For single-strand sprockets without hardened teeth, the Strong Series of sprocket with hardened teeth can be made-to-order.
 6. Models with approximate masses in bold have one hanging hole processed. See the diagram on the right for information.

Hanging Hole Dimensions

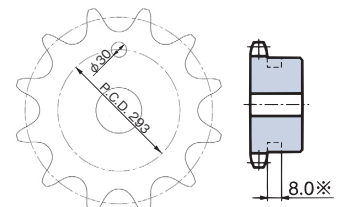

The phase relationship between the hanging hole and teeth may vary.

Sprocket Number

RS60 -2B 15T

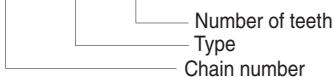

RS80

Before Use

Standard Roller Chains

Lube-Free Roller Chains

Heavy Duty Roller Chains

Corrosion Resistant Roller Chains

Specialty Roller Chains

Sprockets

Pin Gear Drives

Accessories

Selection

Handling

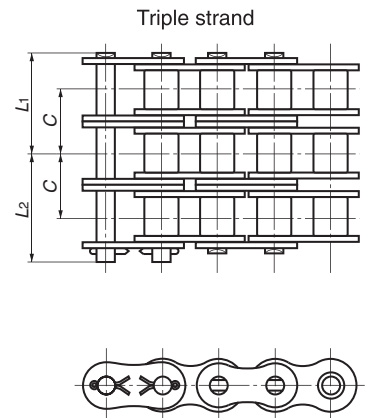
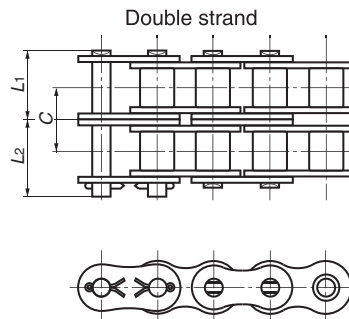
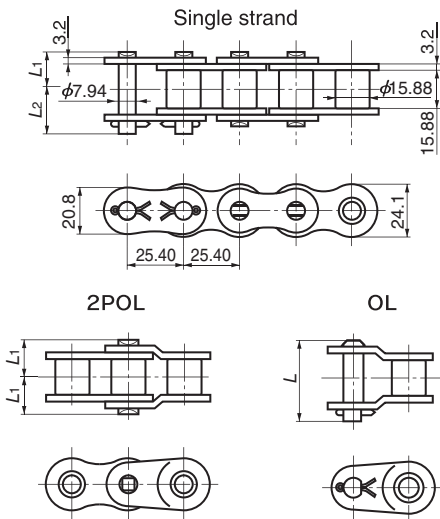

Drawing Scale 1/3.2

TSUBAKI Chain Number	Number of Strands	Pin Length L ₁ +L ₂	Dimensions L ₁	Dimensions L ₂	Offset Pin Length L	Transverse Pitch C	Pin Type	ANSI Standard Min. Tensile Strength kN{kgf}	Tsubaki Minimum Tensile Strength kN{kgf}	Tsubaki Average Tensile Strength kN{kgf}	Maximum Allowable Load kN{kgf}	Approximate Mass kg/m
RS80-1	1	35.5	16.25	19.25	36.6	29.3	Riveting Cotter pin	61.2 {6241}	71.6{7300}	78.5{8000}	14.7{1500}	2.66
RS80-2	2	64.8	30.9	33.9	67.5		Riveting	122.4{12481}	143 {14600}	157 {16000}	25.0{2550}	5.27
RS80-3	3	94.1	45.6	48.5	96.9			183.6{18722}	215 {21900}	235 {24000}	36.8{3750}	7.89
RS80-4	4	123.5	60.25	63.25	126.3			-	286 {29200}	314 {32000}	48.5{4950}	10.50
RS80-5	5	152.9	74.95	77.95	155.6			-	358 {36500}	392 {40000}	57.4{5850}	13.11
RS80-6	6	182.1	89.6	92.5	184.9			-	430 {43800}	471 {48000}	67.7{6900}	15.73

Note: 1. Maximum allowable load when using a one-pitch offset link (OL) is 65% of the above. Two pitch offset links (2POL) can be used at 100% of the above values.
2. Number of links per unit = 120

■ RS80-1 Maximum Kilowatt Ratings Table (kW Ratings for Single Strand Chain)

Small Sprocket No. of Teeth	Lubrication Type	Small Sprocket Max rpm																											
		A							B											C									
		10	25	50	100	150	200	300	400	500	600	700	800	900	1000	1100	1200	1400	1600	1800	2000	2200	2400	2700	3000	3400			
9	0.53	1.21	2.26	4.21	6.07	7.86	11.3	14.7	17.9	18.2	18.2	15.1	12.7	10.8	9.39	8.24	6.54	5.35	4.48	3.83	3.32	2.91	2.44	2.08	1.73				
10	0.59	1.36	2.53	4.72	6.80	8.81	12.7	16.4	20.1	20.4	20.4	17.7	14.9	12.7	11.0	9.65	7.66	6.27	5.25	4.48	3.89	3.41	2.86	2.44	2.02				
11	0.66	1.50	2.80	5.23	7.54	9.76	14.1	18.2	22.3	22.6	22.6	20.4	17.1	14.6	12.7	11.1	8.83	7.23	6.06	5.17	4.48	3.94	3.30	2.82	1.27				
12	0.72	1.65	3.08	5.75	8.28	10.7	15.4	20.0	24.5	24.9	24.9	23.3	19.5	16.7	14.5	12.7	10.1	8.24	6.90	5.89	5.11	4.48	3.76	3.21					
13	0.79	1.80	3.36	6.27	9.03	11.7	16.8	21.8	26.7	27.1	27.1	26.3	22.0	18.8	16.3	14.3	11.3	9.29	7.78	6.65	5.76	5.06	4.24	3.62					
14	0.85	1.95	3.64	6.79	9.78	12.7	18.2	23.6	28.9	29.4	29.4	29.4	24.6	21.0	18.2	16.0	12.7	10.4	8.70	7.43	6.44	5.65	4.74	4.04					
15	0.92	2.10	3.92	7.31	10.5	13.6	19.7	25.5	31.1	32.6	32.6	32.6	27.3	23.3	20.2	17.7	14.1	11.5	9.65	8.24	7.14	6.27	5.25	4.48					
16	0.99	2.25	4.20	7.84	11.3	14.6	21.1	27.3	33.4	35.9	35.9	35.9	30.1	25.7	22.2	19.5	15.5	12.7	10.6	9.08	7.87	6.90	5.79	4.94					
17	1.05	2.40	4.49	8.37	12.1	15.6	22.5	29.2	35.6	39.3	39.3	39.3	32.9	28.1	24.4	21.4	17.0	13.9	11.6	9.94	8.62	7.56	6.34	5.41					
18	1.12	2.56	4.77	8.91	12.8	16.6	23.9	31.0	37.9	42.8	42.8	42.8	35.9	30.6	26.5	23.3	18.5	15.1	12.7	10.8	9.39	8.24	6.90	5.89					
19	1.19	2.71	5.06	9.44	13.6	17.6	25.4	32.9	40.2	46.0	46.0	46.0	38.9	33.2	28.8	25.3	20.1	16.4	13.8	11.7	10.2	8.93	7.49	6.39					
20	1.26	2.87	5.35	9.98	14.4	18.6	26.8	34.8	42.5	48.7	48.7	48.7	42.0	35.9	31.1	27.3	21.7	17.7	14.9	12.7	11.0	9.65	8.09						
21	1.32	3.02	5.64	10.5	15.2	19.6	28.3	36.6	44.8	51.3	51.3	51.3	45.2	38.6	33.5	29.4	23.3	19.1	16.0	13.6	11.8	10.4	8.70						
22	1.39	3.18	5.93	11.1	15.9	20.6	29.7	38.5	47.1	53.9	53.9	53.9	48.5	41.4	35.9	31.5	25.0	20.4	17.1	14.6	12.7	11.1	9.33						
23	1.46	3.33	6.22	11.6	16.7	21.7	31.2	40.4	49.4	56.6	56.6	56.6	51.8	44.2	38.3	33.7	26.7	21.9	18.3	15.6	13.6	11.9	9.97						
24	1.53	3.49	6.51	12.2	17.5	22.7	32.7	42.3	51.7	59.3	59.3	59.3	55.2	47.2	40.9	35.9	28.5	23.3	19.5	16.7	14.5	12.7	10.6						
25	1.60	3.65	6.81	12.7	18.3	23.7	34.1	44.2	54.1	61.9	61.9	61.9	58.7	50.1	43.5	38.1	30.3	24.8	20.8	17.7	15.4	13.5	11.3						
26	1.67	3.80	7.10	13.2	19.1	24.7	35.6	46.1	56.4	64.6	64.6	64.6	62.3	53.2	46.1	40.5	32.1	26.3	22.0	18.8	16.3	14.3	12.0						
28	1.81	4.12	7.69	14.4	20.7	26.8	38.6	50.0	61.1	70.0	70.0	70.0	69.6	59.4	51.5	45.2	35.9	29.4	24.6	21.0	18.2	16.0							
30	1.95	4.44	8.29	15.5	22.3	28.9	41.6	53.8	65.8	77.2	77.2	77.2	77.2	65.9	57.1	50.1	39.8	32.6	27.3	23.3	20.2	17.7							
32	2.09	4.76	8.88	16.6	23.9	30.9	44.6	57.7	70.6	83.2	85.0	85.0	85.0	72.6	62.9	55.2	43.8	35.9	30.1	25.7	22.2	19.5							
35	2.30	5.24	9.79	18.3	26.3	34.1	49.1	63.6	77.7	91.6	97.3	97.3	97.3	83.0	72.0	63.2	50.1	41.0	34.4	29.4	25.5								
40	2.66	6.06	11.3	21.1	30.4	39.4	56.7	73.5	89.8	106	114	114	114	101	87.9	77.2	61.3	50.1	42.0	35.9	14.9								
45	3.02	6.88	12.8	24.0	34.5	44.7	64.4	83.4	102	120	130	130	130	121	105	92.1	73.1	59.8	50.1	40.4									

Note: 1. KW rating when using a one-pitch offset link (OL) is 65% of the above. Two pitch offset links (2POL) can be used at 100% of the above values.
2. Please contact a Tsubaki representative prior to use of kW ratings in the colored area of the table.

Multi-strand factor	Number of chain strands	Multi-strand factor	Number of chain strands	Multi-strand factor	Lubrication method	A	Details on Pg. 193
	Double strand	1.7	Quintuple strand	3.9		B	
	Triple strand	2.5	Sextuple strand	4.6		C	
	Quadruple strand	3.3	-	-		Manual lubrication or drip lubrication	
					Oil bath or slinger disc lubrication		
					Forced pump lubrication		

RS80 Sprocket

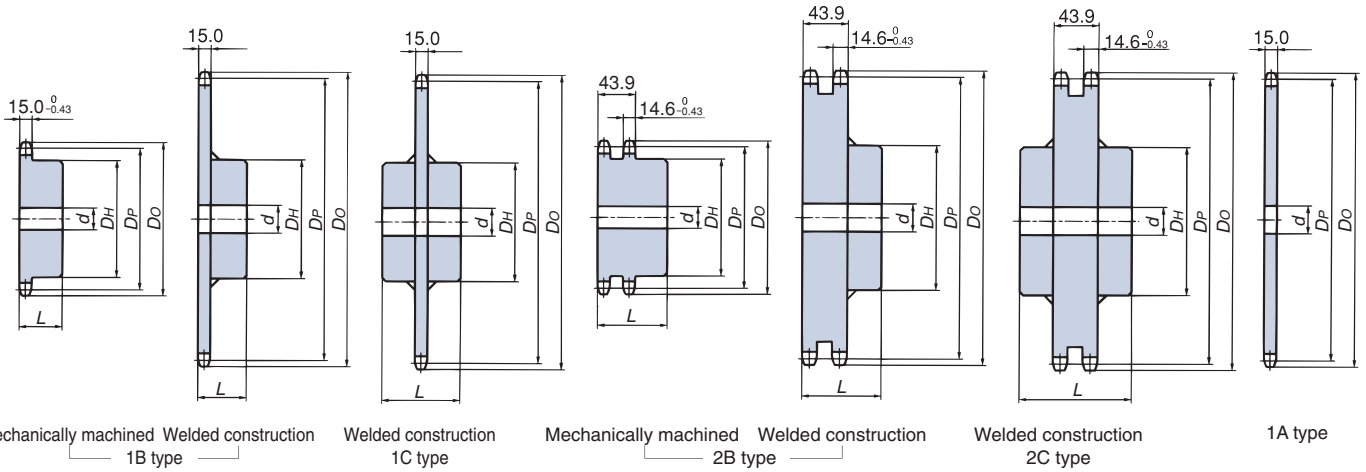

Number of Teeth	Pitch Circular Diameter (Dp)	Sprocket Outer Diameter (Do)	1B type				1C type				2B type				2C type				1A type		Number of Teeth				
			Pilot Bore Diameter	Bore Diameter (d)	Hub Diameter (DH)	Hub Length (L)	Approx. Mass (kg)	Pilot Bore Diameter	Bore Diameter (d)	Hub Diameter (DH)	Hub Length (L)	Approx. Mass (kg)	Pilot Bore Diameter	Bore Diameter (d)	Hub Diameter (DH)	Hub Length (L)	Approx. Mass (kg)	Pilot Bore Diameter	Bore Diameter (d)	Hub Diameter (DH)		Hub Length (L)	Approx. Mass (kg)	Material	
9	74.26	85	15.9	35	58	40	0.79																		9
10	82.20	93	15.9	32	52	40	0.88																		10
11	90.16	102	15.9	38	60	40	1.1																		11
12	98.14	110	19	45	67	40	1.4																		12
13	106.14	118	19	50	77	40	1.7																		13
14	114.15	127	19	50	77	40	1.9																		14
15	122.17	135	19	63	93	40	2.5																		15
16	130.20	143	19	63	93	40	2.7																		16
17	138.23	151	19	63	93	40	2.8																		17
18	146.27	159	19	63	93	40	3.0																		18
19	154.32	167	23	63	93	40	3.2																		19
20	162.37	176	23	63	93	40	3.4																		20
21	170.42	184	23	63	93	40	3.7																		21
22	178.48	192	28	75	107	45	4.7																		22
23	186.54	200	28	75	107	45	4.9																		23
24	194.60	208	28	75	107	45	5.2																		24
25	202.66	216	28	75	107	45	5.5																		25
26	210.72	224	28	75	107	45	5.8																		26
27	218.79	233	28	75	107	45	6.1																		27
28	226.86	241	28	75	107	45	6.4																		28
30	243.00	257	28	75	107	45	7.1																		30
32	259.14	273	28	75	107	45	7.8																		32
34	275.28	289	28	75	107	45	8.6																		34
35	283.36	297	28	75	107	45	9.0																		35
36	291.43	306	33	80	117	50	10.1																		36
38	307.58	322	33	80	117	50	11.0																		38
40	323.74	338	33	80	117	50	12.0																		40
42	339.89	354	33	80	117	50	12.9																		42
45	364.12	378	33	80	117	50	14.5																		45
48	388.36	403	33	80	117	50	16.1																		48
50	404.52	419	33	80	117	50	17.3																		50
54	436.84	451	33	80	117	50	19.8																		54
60	485.33	500	33	80	117	50	23.9																		60
65	525.73	540	33	89	127	63	29.3																		65
70	566.15	581	33	89	127	63	33.3																		70
75	606.56	621	33	89	127	63	37.7																		75

Note: 1. Maximum bore diameter is the typical range. Determine bore diameter and key bearing pressure based on general mechanical design.

2. Models in shaded areas have hardened teeth.
3. Outer diameters above are given for the 1B type. Diameters vary slightly for all other types.
4. 1B-type sprockets marked with an * have an outer groove around the hub. Groove outer diameter is 44 for 9T.
5. For single-strand sprockets without hardened teeth, the Strong Series of sprocket with hardened teeth can be made-to-order.
6. Models with approximate masses in bold have one hanging hole processed. See the diagram on the right for information.
7. Welded specifications, structural rolled steel (teeth and hub).

Hanging Hole Dimensions

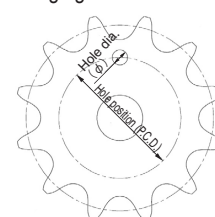

No. of teeth	2B, 2C Type bore dia. (φ30) Hole position (P.C.D.)
40	242
42	258
45	283
48	307
50	323
54	355
60	404

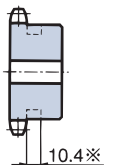

The phase relationship between the hanging hole and teeth may vary.

Sprocket Number

RS80 -2B 15T



RS100

Before Use | Standard Roller Chains | Lubrication-Free Roller Chains | Heavy Duty Roller Chains | Corrosion Resistant Roller Chains | Specialty Roller Chains | Sprockets | Pin Gear Drives | Accessories | Selection | Handling

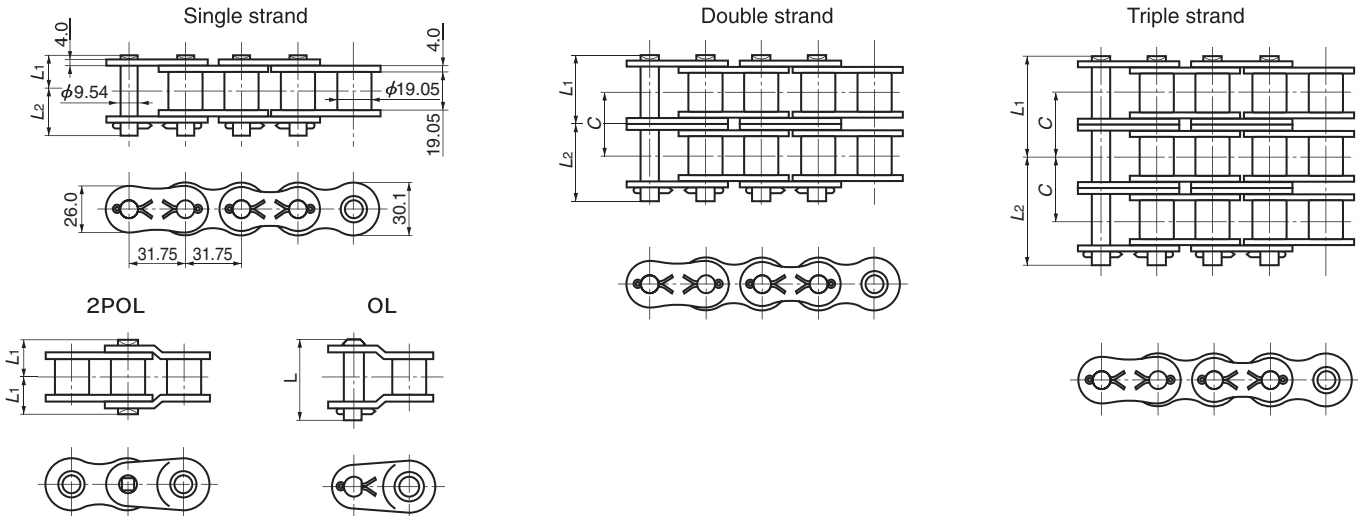

Drawing Scale 1/4

TSUBAKI Chain Number	Number of Strands	Pin Length L ₁ +L ₂	Dimensions L ₁	Dimensions L ₂	Offset Pin Length L	Transverse Pitch C	Pin Type	ANSI Standard Min. Tensile Strength kN{kgf}	Tsubaki Minimum Tensile Strength kN{kgf}	Tsubaki Average Tensile Strength kN{kgf}	Maximum Allowable Load kN{kgf}	Approximate Mass kg/m
RS100-1	1	42.6	19.75	22.85	43.7	35.8	Cotter pin Riveting	95.4 {9728}	107{10900}	118{12000}	22.6 {2300}	3.99
RS100-2	2	78.5	37.7	40.8	81.5		Cotter pin	190.8{19456}	214{21800}	235{24000}	38.3 {3910}	7.85
RS100-3	3	114.4	55.65	58.75	117.3		Riveting	286.2{29184}	321{32700}	353{36000}	56.4 {5750}	11.77
RS100-4	4	150.2	73.55	76.65	153.1			—	428{43600}	471{48000}	74.4 {7590}	15.70
RS100-5	5	186.1	91.5	94.6	188.9			—	534{54500}	588{60000}	88.0 {8970}	19.53
RS100-6	6	222.0	109.45	112.55	224.7			—	641{65400}	706{72000}	104{10580}	23.48

Note: 1. Maximum allowable load when using a one-pitch offset link (OL) is 65% of the above. Two pitch offset links (2POL) can be used at 100% of the above values.
2. Number of links per unit = 96

■ RS100-1 Maximum Kilowatt Ratings Table (kW Ratings for Single Strand Chain)

Small Sprocket No. of Teeth	Small Sprocket Max rpm																									
	A													B						C						
	10	25	50	100	150	200	300	400	500	600	700	800	900	1000	1100	1200	1300	1400	1600	1800	2000	2200	2400	2600		
9	1.02	2.33	4.34	8.10	11.7	15.1	21.8	26.4	26.4	26.4	22.1	18.1	15.2	12.9	11.2	9.85	8.73	7.82	6.40	5.36	4.58	3.97	3.48	3.09		
10	1.14	2.61	4.86	9.07	13.1	16.9	24.4	29.6	29.6	29.6	25.9	21.2	17.8	15.2	13.1	11.5	10.2	9.15	7.49	6.28	5.36	4.65	4.08	3.62		
11	1.27	2.89	5.39	10.1	14.5	18.8	27.0	32.8	32.8	32.8	29.9	24.4	20.5	17.5	15.2	13.3	11.8	10.6	8.64	7.24	6.18	5.36	4.70	0.96		
12	1.39	3.17	5.92	11.0	15.9	20.6	29.7	36.1	36.1	36.1	34.0	27.9	23.3	19.9	17.3	15.2	13.4	12.0	9.85	8.25	7.05	6.11	5.36			
13	1.52	3.46	6.45	12.0	17.3	22.5	32.4	39.3	39.3	39.3	38.4	31.4	26.3	22.5	19.5	17.1	15.2	13.6	11.1	9.31	7.95	6.89	6.04			
14	1.64	3.75	6.99	13.0	18.8	24.3	35.1	42.9	42.9	42.9	42.9	35.1	29.4	25.1	21.8	19.1	16.9	15.2	12.4	10.4	8.88	7.70	6.76			
15	1.77	4.04	7.53	14.1	20.2	26.2	37.8	47.6	47.6	47.6	47.6	38.9	32.6	27.9	24.1	21.2	18.8	16.8	13.8	11.5	9.85	8.54	7.49			
16	1.90	4.33	8.08	15.1	21.7	28.1	40.5	52.4	52.4	52.4	52.4	42.9	35.9	30.7	26.6	23.3	20.7	18.5	15.2	12.7	10.8	9.40	8.25			
17	2.03	4.62	8.62	16.1	23.2	30.0	43.3	56.0	57.4	57.4	57.4	47.0	39.4	33.6	29.1	25.6	22.7	20.3	16.6	13.9	11.9	10.3				
18	2.15	4.92	9.17	17.1	24.7	31.9	46.0	59.6	62.5	62.5	62.5	51.2	42.9	36.6	31.7	27.9	24.7	22.1	18.1	15.2	12.9	11.2				
19	2.28	5.21	9.72	18.1	26.1	33.9	48.8	63.2	67.8	67.8	67.8	55.5	46.5	39.7	34.4	30.2	26.8	24.0	19.6	16.4	14.0	12.2				
20	2.41	5.51	10.3	19.2	27.6	35.8	51.5	66.8	71.9	71.9	71.9	59.9	50.2	42.9	37.2	32.6	28.9	25.9	21.2	17.8	15.2	13.1				
21	2.55	5.81	10.8	20.2	29.1	37.7	54.3	70.4	75.8	75.8	75.8	64.5	54.0	46.1	40.0	35.1	31.1	27.9	22.8	19.1	16.3	14.1				
22	2.68	6.10	11.4	21.3	30.6	39.7	57.1	74.0	79.7	79.7	79.7	69.1	57.9	49.5	42.9	37.6	33.4	29.9	24.4	20.5	17.5	15.2				
23	2.81	6.40	12.0	22.3	32.1	41.6	59.9	77.7	83.7	83.7	83.7	73.9	61.9	52.9	45.8	40.2	35.7	31.9	26.1	21.9	18.7	5.77				
24	2.94	6.71	12.5	23.4	33.6	43.6	62.8	81.3	87.6	87.6	87.6	78.8	66.0	56.4	48.9	42.9	38.0	34.0	27.9	23.3	19.9					
25	3.07	7.01	13.1	24.4	35.2	45.5	65.6	85.0	91.5	91.5	91.5	83.8	70.2	59.9	51.9	45.6	40.4	36.2	29.6	24.8	21.2					
26	3.21	7.31	13.6	25.5	36.7	47.5	68.4	88.7	95.5	95.5	95.5	88.8	74.4	63.6	55.1	48.4	42.9	38.4	31.4	26.3	22.5					
28	3.47	7.92	14.8	27.6	39.7	51.5	74.1	96.0	103	103	103	99.3	83.2	71.0	61.6	54.0	47.9	42.9	35.1	29.4	25.1					
30	3.74	8.53	15.9	29.7	42.8	55.5	79.9	103	111	111	111	110	92.3	78.8	68.3	59.9	53.2	47.6	38.9	32.6	7.5					
32	4.01	9.15	17.1	31.9	45.9	59.5	85.6	111	121	121	121	121	102	86.8	75.2	66.0	58.6	52.4	42.9	33.7						
35	4.42	10.1	18.8	35.1	50.6	65.5	94.3	122	139	139	139	139	116	99.3	86.1	75.5	67.0	59.9	49.1	41.1						
40	5.10	11.6	21.7	40.5	58.4	75.7	109	141	170	170	170	170	142	121	105	92.3	81.8	73.2	59.9							
45	5.80	13.2	24.7	46.0	66.3	85.9	124	160	196	196	196	195	170	145	125	110	97.6	87.4	33.8							

Note: 1. kW rating when using a one-pitch offset link (OL) is 65% of the above. Two pitch offset links (2POL) can be used at 100% of the above values.
2. Please contact a Tsubaki representative prior to use of kW ratings in the colored area of the table.

Multi-strand factor	Number of chain strands	Multi-strand factor	Number of chain strands	Multi-strand factor	Lubrication method	A	Details on Pg. 193
	Double strand	1.7	Quintuple strand	3.9		B	
	Triple strand	2.5	Sextuple strand	4.6		C	
	Quadruple strand	3.3	—	—		Manual lubrication or drip lubrication	
					Oil bath or slinger disc lubrication		
					Forced pump lubrication		

RS100 Sprocket

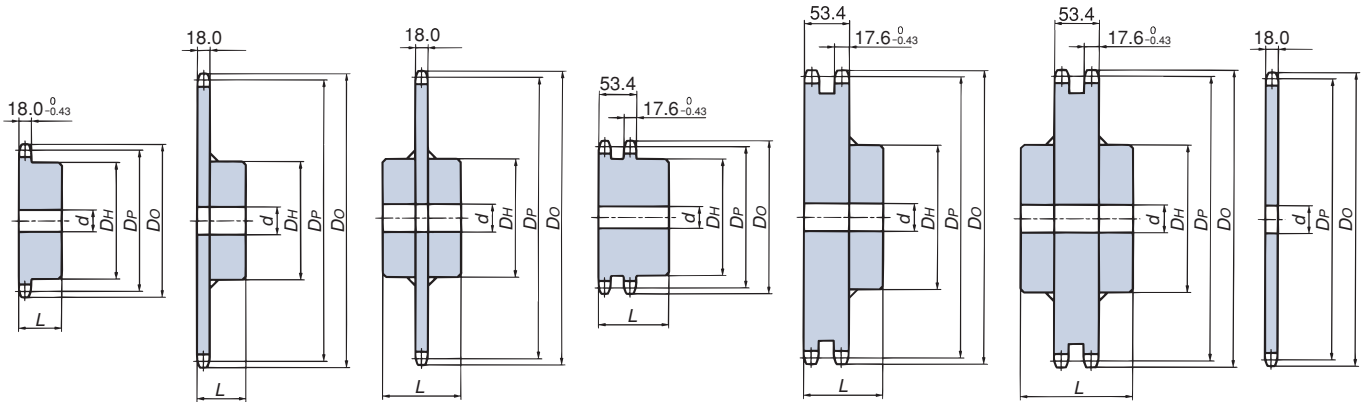

Mechanically machined 1B type Welded construction 1C type Welded construction 2B type Welded construction 2C type 1A type

Number of Teeth	Pitch Circular Diameter (D _p)	Sprocket Outer Diameter (D _o)	1B type				1C type				2B type				2C type				1A type		Number of Teeth			
			Pilot Bore Diameter	Maximum Bore Diameter (d)	Hub Diameter (D _H)	Hub Length (L)	Approx. Mass (kg)	Material	Pilot Bore Diameter	Maximum Bore Diameter (d)	Hub Diameter (D _H)	Hub Length (L)	Approx. Mass (kg)	Material	Pilot Bore Diameter	Maximum Bore Diameter (d)	Hub Diameter (D _H)	Hub Length (L)	Approx. Mass (kg)	Material		Pilot Bore Diameter	Approx. Mass (kg)	Material
10	102.75	117	18	43	65	50	1.8																	10
11	112.70	127	23	50	75	50	2.2																	11
12	122.67	138	23	57	86	50	2.8																	12
13	132.67	148	23	59	88	50	3.1																	13
14	142.68	158	23	59	88	50	3.4																	14
15	152.71	168	28	66	98	50	4.0																	15
16	162.75	179	28	66	98	50	4.3																	16
17	172.79	189	28	75	107	50	5.1																	17
18	182.84	199	28	75	107	50	5.4																	18
19	192.90	209	28	75	107	50	5.8																	19
20	202.96	220	28	75	107	50	6.3																	20
21	213.03	230	28	75	107	50	6.7																	21
22	223.10	240	33	80	117	56	8.1																	22
23	233.17	250	33	80	117	56	8.6																	23
24	243.25	260	33	80	117	56	9.1																	24
25	253.32	270	33	80	117	56	9.6																	25
26	263.41	281	33	80	117	56	10.2																	26
27	273.49	291	33	80	117	56	10.8																	27
28	283.57	301	33	80	117	56	11.4																	28
30	303.75	321	33	80	117	56	12.7																	30
32	323.92	341	33	80	117	56	14.1																	32
34	344.10	362	33	89	127	63	16.8																	34
35	354.20	372	33	89	127	63	17.5																	35
36	364.29	382	33	89	127	63	18.3																	36
38	384.48	402	33	89	127	63	20.0																	38
40	404.67	422	33	89	127	63	21.7																	40
42	424.86	443	33	89	127	63	23.6																	42
45	455.15	473	33	89	127	63	26.5																	45
48	485.45	503	33	89	127	63	29.3																	48
50	505.65	524	33	89	127	63	31.5																	50
54	546.05	564	33	103	147	80	39.7																	54
60	606.66	625	33	103	147	80	47.4																	60
65	657.17	675	33	103	147	80	54.1																	65
70	707.68	726	33	103	147	80	61.8																	70
75	758.20	777	33	103	147	80	70.0																	75

- Note: 1. Maximum bore diameter is the typical range. Determine bore diameter and key bearing pressure based on general mechanical design.
 2. Models in shaded areas have hardened teeth.
 3. Outer diameters above are given for the 1B type. Diameters vary slightly for all other types.
 4. For single-strand sprockets without hardened teeth, the Strong Series of sprocket with hardened teeth can be made-to-order.
 5. Models with approximate masses in bold have one hanging hole processed.
 See the diagram on the right for information.

Hanging Hole Dimensions

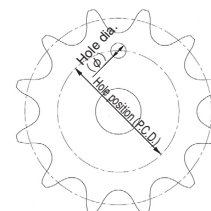

No. of teeth	1B, 1C, 1A Type bore dia. (φ40) Hole position (P.C.D.)	2B, 2C Type bore dia. (φ35) Hole position (P.C.D.)
32		224
34		245
35		255
36		265
38		285
40		305
42		326
45		356
48	392	386
50	412	407
54	453	447
60	513	508
65	564	
70	614	
75	665	

The phase relationship between the hanging hole and teeth may vary.

Sprocket Number

RS100 -2B 15T



RS120

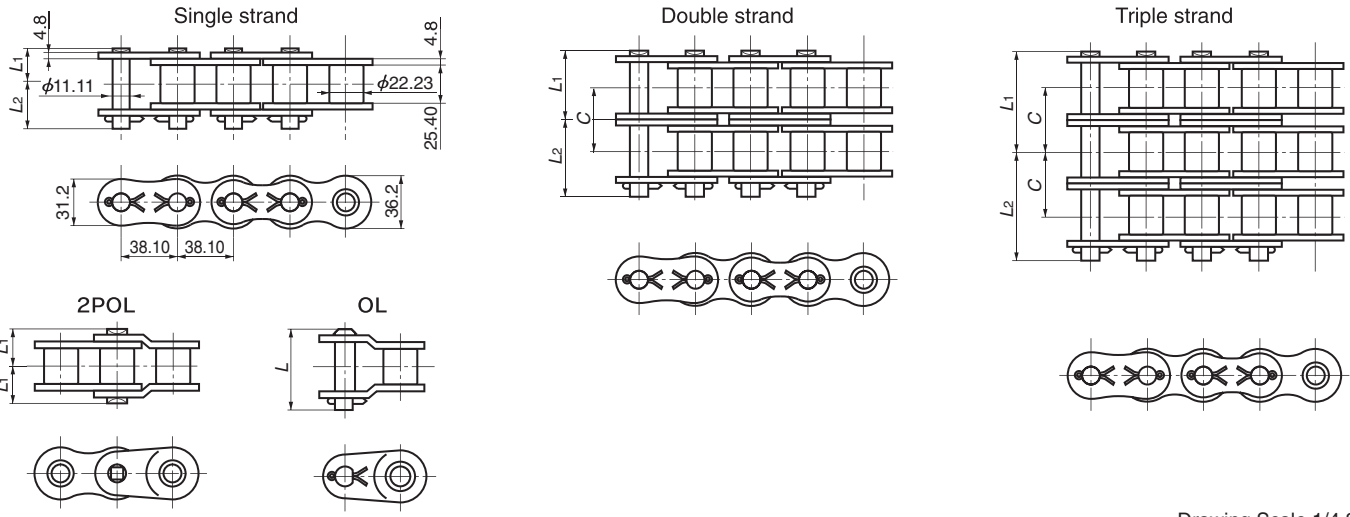

Drawing Scale 1/4.8

TSUBAKI Chain Number	Number of Strands	Pin Length L ₁ +L ₂	Dimensions L ₁	Dimensions L ₂	Offset Pin Length L	Transverse Pitch C	Pin Type	ANSI Standard Min. Tensile Strength kN{kgf}	Tsubaki Minimum Tensile Strength kN{kgf}	Tsubaki Average Tensile Strength kN{kgf}	Maximum Allowable Load kN{kgf}	Approximate Mass kg/m
RS120-1	1	53.8	24.9	28.9	55.0	45.4	Cotter pin Riveting	137.1{13980}	148{15100}	167 {17000}	30.4 {3100}	5.93
RS120-2	2	99.2	47.6	51.6	103.2		Cotter pin	274.2{27961}	296{30200}	333 {34000}	51.7 {5270}	11.70
RS120-3	3	144.8	70.4	74.4	148.6		Riveting	411.3{41941}	444{45300}	500 {51000}	76.0 {7750}	17.53
RS120-4	4	190.2	93.1	97.1	194.0			-	592{60400}	667 {68000}	100{10230}	23.36
RS120-5	5	235.7	115.85	119.85	239.4		-	-	740{75500}	834 {85000}	119{12090}	29.16
RS120-6	6	281.1	138.55	142.55	284.8		-	-	888{90600}	1000{102000}	140{14260}	34.96

Note: 1. Maximum allowable load when using a one-pitch offset link (OL) is 65% of the above. Two pitch offset links (2POL) can be used at 100% of the above values.
 2. Number of links per unit = 80

■ RS120-1 Maximum Kilowatt Ratings Table (kW Ratings for Single Strand Chain)

Small Sprocket No. of Teeth	Small Sprocket Max rpm																								
	A							B							C										
	10	25	50	100	150	200	300	400	500	600	700	800	900	1000	1100	1200	1300	1400	1500	1600	1700	1800	1900	2000	2100
9	1.65	3.75	7.00	13.1	18.8	24.4	35.1	41.1	41.1	32.2	25.6	20.9	17.5	15.0	13.0	11.4	10.1	9.04	8.15	7.40	6.76	6.20	5.72	5.30	4.92
10	1.84	4.21	7.85	14.6	21.1	27.3	39.4	46.1	46.0	37.7	30.0	24.5	20.5	17.5	15.2	13.3	11.8	10.6	9.55	8.67	7.91	7.26	6.70	6.20	5.76
11	2.04	4.66	8.70	16.2	23.4	30.3	43.6	51.0	51.0	43.5	34.6	28.3	23.7	20.2	17.5	15.4	13.7	12.2	11.0	10.0	9.13	8.38	7.73	7.16	6.71
12	2.24	5.12	9.56	17.8	25.7	33.3	47.9	56.1	56.1	49.6	39.4	32.2	27.0	23.1	20.0	17.5	15.6	13.9	12.6	11.4	10.4	9.55	8.81	8.15	7.70
13	2.45	5.58	10.4	19.4	28.0	36.3	52.3	61.1	61.1	55.9	44.4	36.3	30.5	26.0	22.5	19.8	17.5	15.7	14.2	12.8	11.7	10.8	9.93	9.19	8.74
14	2.65	6.05	11.3	21.1	30.3	39.3	56.6	66.2	66.2	62.5	49.6	40.6	34.0	29.1	25.2	22.1	19.6	17.5	15.8	14.4	13.1	12.0	11.1	10.3	9.89
15	2.86	6.52	12.2	22.7	32.7	42.3	61.0	71.3	71.3	69.3	55.0	45.0	37.7	32.2	27.9	24.5	21.7	19.5	17.5	15.9	14.5	13.3	12.3	11.5	11.0
16	3.06	6.99	13.0	24.3	35.0	45.4	65.4	76.5	76.5	76.4	60.6	49.6	41.6	35.5	30.8	27.0	24.0	21.4	19.3	17.5	16.0	14.7	13.6	12.8	12.3
17	3.27	7.46	13.9	26.0	37.4	48.5	69.8	83.7	83.7	83.7	66.4	54.3	45.5	38.9	33.7	29.6	26.2	23.5	21.2	19.2	17.5	16.1	14.8	14.0	13.5
18	3.48	7.93	14.8	27.6	39.8	51.6	74.3	91.2	91.2	91.2	72.3	59.2	49.6	42.4	36.7	32.2	28.6	25.6	23.1	20.9	19.1	17.5	16.1	14.8	14.3
19	3.69	8.41	15.7	29.3	42.2	54.7	78.7	98.9	98.9	98.9	78.4	64.2	53.8	45.9	39.8	35.0	31.0	27.7	25.0	22.7	20.7	19.0	17.6	16.2	15.7
20	3.90	8.89	16.6	31.0	44.6	57.8	83.2	107	107	107	84.7	69.3	58.1	49.6	43.0	37.7	33.5	30.0	27.0	24.5	22.4	20.5	19.1	17.7	17.2
21	4.11	9.37	17.5	32.6	47.0	60.9	87.7	114	115	115	91.2	74.6	62.5	53.4	46.3	40.6	36.0	32.2	29.1	26.4	24.1	22.1	20.7	19.3	18.8
22	4.32	9.85	18.4	34.3	49.4	64.0	92.2	119	123	123	97.7	80.0	67.0	57.2	49.6	43.5	38.6	34.6	31.2	28.3	25.8	23.8	22.4	21.0	20.5
23	4.53	10.3	19.3	36.0	51.9	67.2	96.8	125	132	132	104	85.5	71.7	61.2	53.0	46.6	41.3	36.9	33.3	30.2	27.6	25.2	23.8	22.4	21.9
24	4.75	10.8	20.2	37.7	54.3	70.3	101	131	140	140	111	91.2	76.4	65.2	56.5	49.6	44.0	39.4	35.5	32.2	29.4	27.0	25.6	24.2	23.7
25	4.96	11.3	21.1	39.4	56.7	73.5	106	137	146	146	118	96.9	81.2	69.3	60.1	52.8	46.8	41.9	37.7	34.3	30.8	28.4	27.0	25.6	25.1
26	5.17	11.8	22.0	41.1	59.2	76.7	110	143	152	152	126	103	86.1	73.5	63.7	55.9	49.6	44.4	40.0	36.3	32.8	30.4	29.0	27.6	27.1
28	5.61	12.8	23.9	44.5	64.1	83.1	120	155	165	165	140	115	96.3	82.2	71.2	62.5	55.5	49.6	44.7	40.6	37.2	34.8	33.4	32.0	31.5
30	6.04	13.8	25.7	48.0	69.1	89.5	129	167	178	178	156	127	107	91.2	79.0	69.3	61.5	55.0	49.6	45.2	42.8	41.4	40.0	38.6	38.1
32	6.47	14.8	27.6	51.4	74.1	96.0	138	179	191	191	171	140	118	100	87.0	76.4	67.8	60.6	54.7	50.2	47.8	46.4	45.0	43.6	43.1
35	7.13	16.3	30.4	56.7	81.6	106	152	197	210	210	196	161	135	115	99.6	87.4	77.5	69.3	63.6	59.2	56.8	55.4	54.0	52.6	52.1
40	8.24	18.8	35.1	65.4	94.3	122	176	228	242	242	240	196	164	140	122	107	94.7	84.4	78.0	75.6	74.2	72.8	71.4	70.0	69.6
45	9.36	21.3	39.8	74.3	107	139	200	259	286	286	286	234	196	167	145	127	107	97.0	91.6	89.2	87.8	86.4	85.0	83.6	83.2

Note: 1. kW rating when using a one-pitch offset link (OL) is 65% of the above. Two pitch offset links (2POL) can be used at 100% of the above values.
 2. Please contact a Tsubaki representative prior to use of kW ratings in the colored area of the table.

Multi-strand factor	Number of chain strands	Multi-strand factor	Number of chain strands	Multi-strand factor	Lubrication method	A	Manual lubrication or drip lubrication	Details on Pg. 193
	Double strand	1.7	Quintuple strand	3.9		B	Oil bath or slinger disc lubrication	
	Triple strand	2.5	Sextuple strand	4.6		C	Forced pump lubrication	
	Quadruple strand	3.3	-	-				

RS120 Sprocket

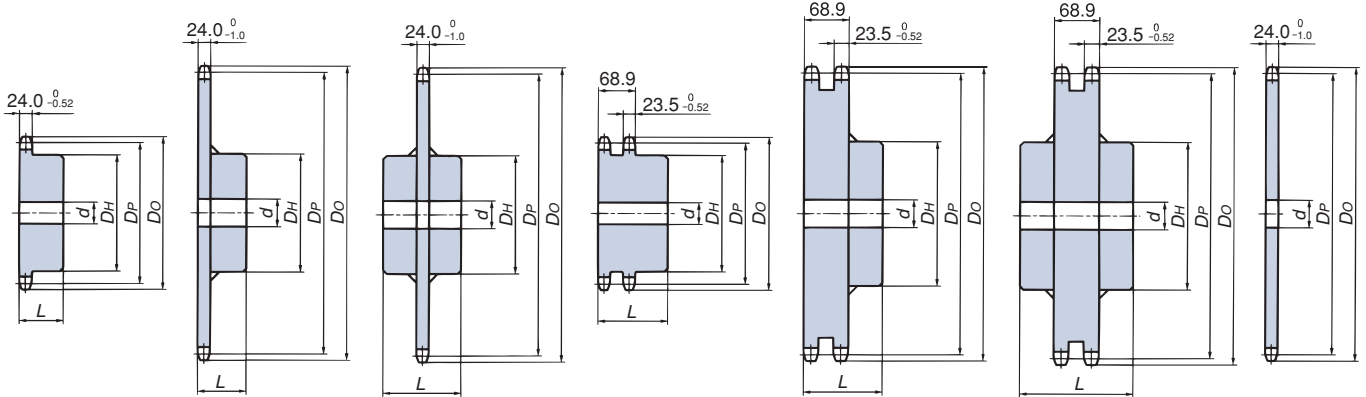

Mechanically machined 1B type Welded construction 1C type Mechanically machined 2B type Welded construction 2C type 1A type

Number of Teeth	Pitch Circular Diameter (Dp)	Sprocket Outer Diameter (Do)	1B type					1C type					2B type					2C type					1A type			Number of Teeth	
			Bore Diameter (d)	Hub Diameter (Dh)	Hub Length (L)	Approx. Mass (kg)	Material	Bore Diameter (d)	Hub Diameter (Dh)	Hub Length (L)	Approx. Mass (kg)	Material	Bore Diameter (d)	Hub Diameter (Dh)	Hub Length (L)	Approx. Mass (kg)	Material	Bore Diameter (d)	Hub Diameter (Dh)	Hub Length (L)	Approx. Mass (kg)	Material	Pitch Diameter	Approx. Mass (kg)	Material		
10	123.29	140	23	51	78	56	3.0																				10
11	135.23	153	28	60	91	56	3.8																				11
12	147.21	165	28	66	98	56	4.5																				12
13	159.20	177	28	66	98	56	5.0																				13
14	171.22	190	28	75	107	56	6.0																				14
15	183.25	202	33	80	117	63	7.4																				15
16	195.29	214	33	80	117	63	8.1																				16
17	207.35	227	33	80	117	63	8.8																				17
18	219.41	239	33	80	117	63	9.5																				18
19	231.48	251	33	80	117	63	10.3																				19
20	243.55	263	33	89	127	63	11.7																				20
21	255.63	276	33	89	127	63	12.5																				21
22	267.72	288	33	89	127	63	13.6	33	89	127	80	15.1															22
23	279.80	300	33	89	127	63	14.6	33	89	127	80	16.1															23
24	291.90	312	33	89	127	63	15.6	33	89	127	80	17.0															24
25	303.99	324	33	89	127	63	16.6	33	89	127	80	18.1															25
26	316.09	337	33	89	127	63	17.7	33	89	127	80	19.2															26
27	328.19	349	33	89	127	63	18.8	33	89	127	80	20.3															27
28	340.29	361	33	103	147	71	22.3	33	95	137	100	24.5															28
30	364.49	385	33	103	147	71	24.8	33	95	137	100	27.0															30
32	388.71	410	33	103	147	71	27.4	33	95	137	100	29.6															32
34	412.93	434	33	103	147	71	30.2	33	95	137	100	32.5															34
35	425.04	446	33	103	147	71	31.4	33	95	137	100	33.7															35
36	437.15	458	33	103	147	71	33.0	33	95	137	100	35.2															36
38	461.37	483	38	103	147	80	37.1	38	103	147	100	39.5															38
40	485.60	507	38	103	147	80	40.4	38	103	147	100	42.8															40
42	509.83	531	38	103	147	80	43.9	38	103	147	110	47.5															42
45	546.19	568	38	103	147	80	49.5	38	103	147	110	53.1															45
48	582.54	604	38	103	147	80	55.4	38	103	147	110	59.1															48
50	606.78	628	38	103	147	80	59.6	38	103	147	110	63.3															50
54	655.26	677	38	110	157	90	71.1	38	103	147	110	72.2															54
60	727.99	750	38	110	157	90	85.8	38	118	167	120	91.8															60
65	788.60	811	38	118	167	94	101.2	38	118	167	120	105.2															65
70	849.22	871	38	118	167	94	115.7	38	118	167	120	119.7															70
75	909.84	932	38	118	167	94	131.3	38	118	167	120	135.2															75

Note: 1. Maximum bore diameter is the typical range. Determine bore diameter and key bearing pressure based on general mechanical design.
 2. Models in shaded areas have hardened teeth.
 3. Outer diameters above are given for the 1B type. Diameters vary slightly for all other types.
 4. For sprockets without hardened teeth, the Strong Series of sprocket with hardened teeth can be made-to-order.
 5. Models with approximate masses in bold have one hanging hole processed.
 See the diagram on the right for information.

Hanging Hole Dimensions

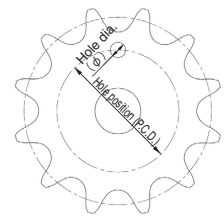

The phase relationship between the hanging hole and teeth may vary.

No. of Teeth	1B, 1C, 1A Type bore dia. (φ40) Hole position (P.C.D.)	2B, 2C Type bore dia. (φ35) Hole position (P.C.D.)
30	258	258
32	382	382
34	307	307
35	319	319
36	331	331
38	359	355
40	383	380
42	407	404
45	443	440
48	480	477
50	504	501
54	553	550
60	625	623
65	686	686
70	746	746
75	807	807

Sprocket Number

RS120 -2B 15T

Number of teeth
 Type
 Chain number

RS140

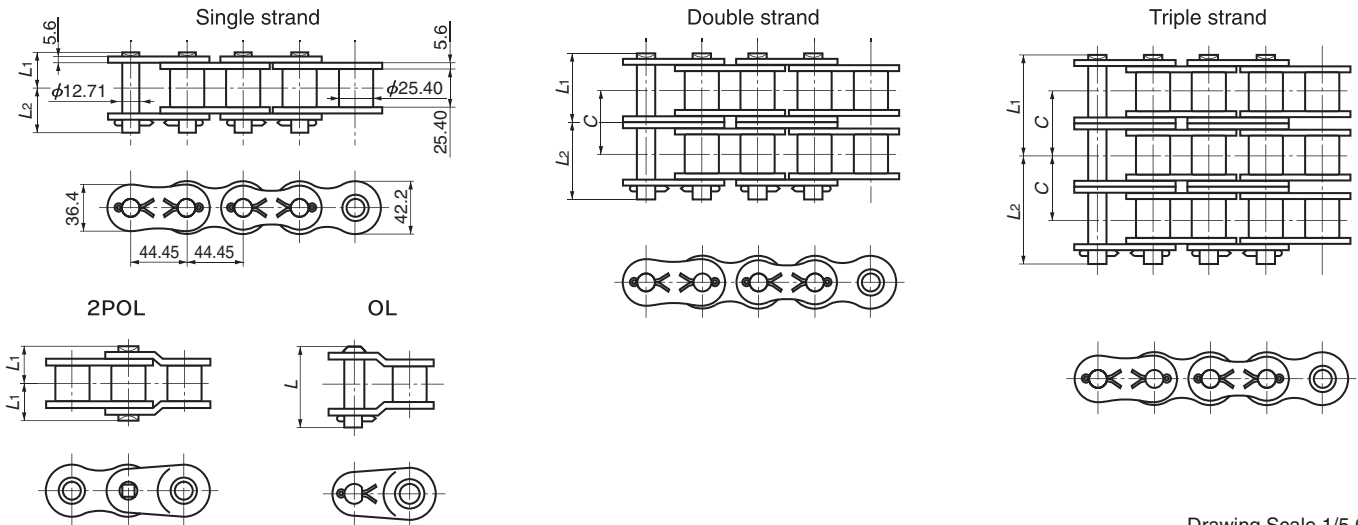

Drawing Scale 1/5.6

TSUBAKI Chain Number	Number of Strands	Pin Length L _{1+L2}	Dimensions L ₁	Dimensions L ₂	Offset Pin Length L	Transverse Pitch C	Pin Type	ANSI Standard Min. Tensile Strength kN{kgf}	Tsubaki Minimum Tensile Strength kN{kgf}	Tsubaki Average Tensile Strength kN{kgf}	Maximum Allowable Load kN{kgf}	Approximate Mass kg/m
RS140-1	1	58.6	26.9	31.7	59.5	48.9	Cotter pin	185.9{18957}	193{19700}	216{22000}	40.2{4100}	7.49
RS140-2	2	107.5	51.35	56.15	112.3			371.8{37913}	386{39400}	431{44000}	68.4{6970}	14.83
RS140-3	3	156.6	75.85	80.75	161.3			557.7{56870}	580{59100}	647{66000}	101{10250}	22.20
RS140-4	4	205.5	100.3	105.2	210.2		-	773{78800}	863{88000}	133{13530}	28.52	
RS140-5	5	254.4	124.8	129.6	259.1		-	966{98500}	1080{110000}	157{15990}	36.97	
RS140-6	6	303.5	149.3	154.2	308.0		-	1160{118200}	1290{132000}	185{18860}	44.30	

Note: 1. Maximum allowable load when using a one-pitch offset link (OL) is 65% of the above. Two pitch offset links (2POL) can be used at 100% of the above values.
2. Number of links per unit = 80

■ RS140-1 Maximum Kilowatt Ratings Table (kW Ratings for Single Strand Chain)

Lubrication Type Small Sprocket No. of Teeth	Small Sprocket Max rpm																								
	10	25	50	100	150	200	250	300	350	400	450	500	550	600	700	800	900	1000	1100	1200	1300	1400	1500	1600	1700
	A					B										C									
9	2.54	5.79	10.8	20.2	29.0	37.6	46.0	54.2	56.1	56.1	47.9	41.5	36.5	28.9	23.7	19.8	16.9	14.7	12.9	11.4	10.2	9.22	8.37	7.64	
10	2.84	6.49	12.1	22.6	32.5	42.2	51.5	60.7	65.6	65.6	56.1	48.7	42.7	33.9	27.7	23.2	19.8	17.2	15.1	13.4	12.0	10.8	9.81		
11	3.15	7.19	13.4	25.0	36.1	46.7	57.1	67.3	72.7	72.7	64.8	56.1	49.3	39.1	32.0	26.8	22.9	19.8	17.4	15.4	13.8	12.5	11.3		
12	3.46	7.90	14.7	27.5	39.6	51.3	62.7	73.9	79.9	79.9	73.8	64.0	56.1	44.5	36.5	30.6	26.1	22.6	19.8	17.6	15.7	14.2	12.9		
13	3.78	8.61	16.1	30.0	43.2	56.0	68.4	80.6	87.1	87.1	83.2	72.1	63.3	50.2	41.1	34.5	29.4	25.5	22.4	19.8	17.8	16.0	14.5		
14	4.09	9.33	17.4	32.5	46.8	60.6	74.1	87.3	94.4	94.4	93.0	80.6	70.7	56.1	45.9	38.5	32.9	28.5	25.0	22.2	19.8	17.9	16.2		
15	4.41	10.1	18.8	35.0	50.4	65.3	79.8	94.1	103	103	103	89.4	78.4	62.3	51.0	42.7	36.5	31.6	27.7	24.6	22.0	19.8			
16	4.72	10.8	20.1	37.5	54.1	70.0	85.6	101	114	114	114	98.5	86.4	68.6	56.1	47.0	40.2	34.8	30.6	27.1	24.2	21.9			
17	5.04	11.5	21.5	40.1	57.7	74.8	91.4	108	124	124	124	108	94.6	75.1	61.5	51.5	44.0	38.1	33.5	29.7	26.6	23.9			
18	5.37	12.2	22.8	42.6	61.4	79.5	97.2	115	132	136	136	117	103	81.8	67.0	56.1	47.9	41.5	36.5	32.3	28.9	26.1			
19	5.69	13.0	24.2	45.2	65.1	84.3	103	121	140	144	144	127	112	88.7	72.6	60.9	52.0	45.1	39.5	35.1	31.4	28.3			
20	6.01	13.7	25.6	47.8	68.8	89.1	109	128	147	152	152	138	121	95.8	78.4	65.7	56.1	48.7	42.7	37.9	33.9				
21	6.34	14.5	27.0	50.3	72.5	93.9	115	135	155	161	161	148	130	103	84.4	70.7	60.4	52.3	45.9	40.7	36.5				
22	6.66	15.2	28.4	52.9	76.3	98.8	121	142	163	169	169	159	139	111	90.5	75.8	64.8	56.1	49.3	43.7	39.1				
23	6.99	15.9	29.8	55.5	80.0	104	127	149	172	177	177	170	149	118	96.7	81.1	69.2	60.0	52.7	46.7	41.8				
24	7.32	16.7	31.2	58.2	83.8	109	133	156	180	186	186	181	159	126	103	86.4	73.8	64.0	56.1	49.8	44.5				
25	7.65	17.5	32.6	60.8	87.5	113	139	163	188	194	194	192	169	134	110	91.9	78.4	68.0	59.7	52.9	47.4				
26	7.98	18.2	34.0	63.4	91.3	118	145	170	196	204	204	204	179	142	116	97.4	83.2	72.1	63.3	56.1					
28	8.65	19.7	36.8	68.7	98.9	128	157	185	212	228	228	228	200	159	130	109	93.0	80.6	70.7	62.7					
30	9.32	21.3	39.7	74.0	107	138	169	199	229	253	253	253	222	176	144	121	103	89.4	78.4	69.6					
32	9.99	22.8	42.5	79.3	114	148	181	213	245	276	276	276	244	194	159	133	114	98.5	86.4						
35	11.0	25.1	46.8	87.4	126	163	199	235	270	304	304	304	280	222	182	152	130	113	98.9						
40	12.7	29.0	54.1	101	145	188	230	271	312	351	351	351	342	271	222	186	159	133							
45	14.4	32.9	61.4	115	165	214	262	308	354	399	408	408	408	323	265	222	177	69.2							

Note: 1. KW rating when using a one-pitch offset link (OL) is 65% of the above. Two pitch offset links (2POL) can be used at 100% of the above values.
2. Please contact a Tsubaki representative prior to use of kW ratings in the colored area of the table.

Multi-strand factor	Number of chain strands	Multi-strand factor	Number of chain strands	Multi-strand factor
	Double strand	1.7	Quintuple strand	3.9
	Triple strand	2.5	Sextuple strand	4.6
	Quadruple strand	3.3	-	-

Lubrication method	A	Manual lubrication or drip lubrication	Details on Pg. 193
	B	Oil bath or slinger disc lubrication	
	C	Forced pump lubrication	

RS140 Sprocket

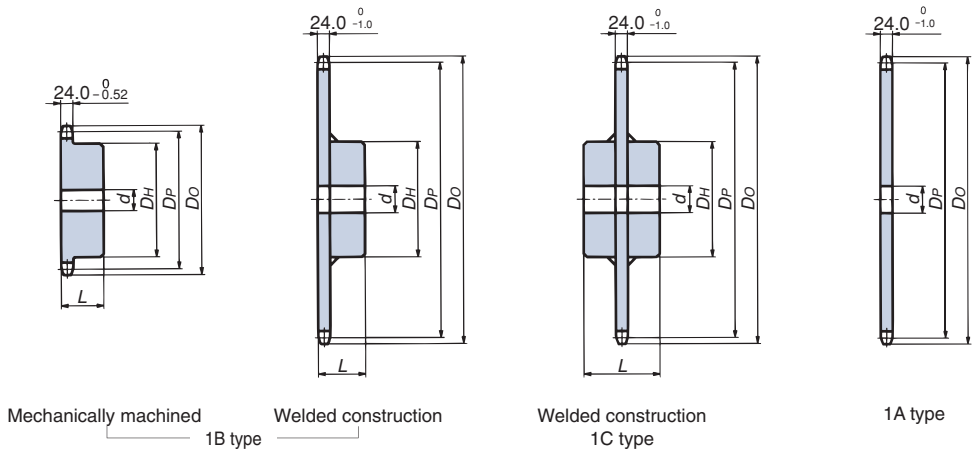

Number of Teeth	Pitch Circular Diameter (Dp)	Sprocket Outer Diameter (Do)	1B type					1C type					1A type			Number of Teeth										
			Bore Diameter (d)		Hub		Approx. Mass (kg)	Material	Bore Diameter (d)		Hub		Approx. Mass (kg)	Material	Pilot Bore Diameter (d)		Approx. Mass (kg)	Material								
			Pilot Bore Diameter	Maximum	Diameter (DH)	Length (L)			Pilot Bore Diameter	Maximum	Diameter (DH)	Length (L)														
10	143.84	163	28	60	91	56	4.1	Mechanically machined: machine-structural carbon steel	33	103	147	115	25.1	carbon steel (teeth) and structural rolled steel (hub)	28	2.6	Machine-structural carbon steel	10								
11	157.77	178	33	73	106	56	5.1								33	3.2		11								
12	171.74	193	33	80	117	56	6.3								33	3.8		12								
13	185.74	207	33	80	117	63	7.5								33	4.5		13								
14	199.76	221	33	89	127	63	8.9								33	5.3		14								
15	213.79	236	33	89	127	63	9.7								33	6.1		15								
16	227.84	250	33	89	127	63	10.6								33	7.0		16								
17	241.91	264	33	89	127	63	11.5								33	7.9		17								
18	255.98	279	33	89	127	63	12.5								33	9.0		18								
19	270.06	293	33	95	137	71	15.1								33	10.0		19								
20	284.14	307	33	95	137	71	16.2								Welded construction: machine-structural carbon steel (teeth) and structural rolled steel (hub)	38		103	147	115	28.9	38	33	11.1	Machine-structural carbon steel	20
21	298.24	322	33	95	137	71	17.4																33	12.3		21
22	312.34	336	33	103	147	71	19.6																33	13.6		22
23	326.44	350	33	103	147	71	21.0																33	14.8		23
24	340.54	364	33	103	147	71	22.3																33	16.2		24
25	354.65	379	38	103	147	80	24.7																38	17.6		25
26	368.77	393	38	103	147	80	26.0																38	18.8		26
27	382.88	407	38	103	147	80	27.6																38	20.3		27
28	397.00	421	38	103	147	80	29.2																38	21.9		28
30	425.24	450	38	103	147	80	32.6	38	25.3	30																
32	453.49	478	38	103	147	80	36.3	38	28.9	32																
34	481.75	506	38	103	147	80	40.1	38	32.7	34																
35	495.88	521	38	110	157	90	44.6	38	34.7	35																
36	510.01	535	38	110	157	90	46.7	38	36.8	36																
38	538.27	563	38	110	157	90	51.1	38	41.1	38																
40	566.54	591	38	110	157	90	55.6	38	45.6	40																
42	594.81	620	38	118	167	94	62.3	38	50.4	42																
45	637.22	662	38	118	167	94	70.0	38	58.0	45																
48	679.63	705	38	118	167	94	78.3	38	66.1	48																
50	707.91	733	38	118	167	94	84.0	38	71.8	50																
54	764.47	790	38	118	167	94	96.7	38	84.0	54																
60	849.32	875	38	118	167	94	116.6	38	103.9	60																

- Note: 1. Maximum bore diameter is the typical range. Determine bore diameter and key bearing pressure based on general mechanical design.
 2. Models in shaded areas have hardened teeth.
 3. For sprockets without hardened teeth, the Strong Series of sprocket with hardened teeth can be made-to-order.
 4. Models with approximate masses in bold have one hanging hole processed.
 See the diagram on the right for information.

Sprocket Number

RS140 -1B 15T



Hanging Hole Dimensions

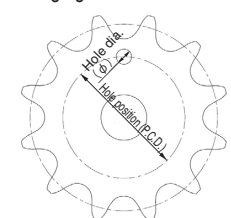

The phase relationship between the hanging hole and teeth may vary.

No. of teeth	1B, 1C, 1A Type bore dia. (d40) Hole position (P.C.D.)
26	263
27	277
28	291
30	319
32	348
34	376
35	390
36	404
38	432
40	461
42	489
45	531
48	574
50	602
54	659
60	743

RS160

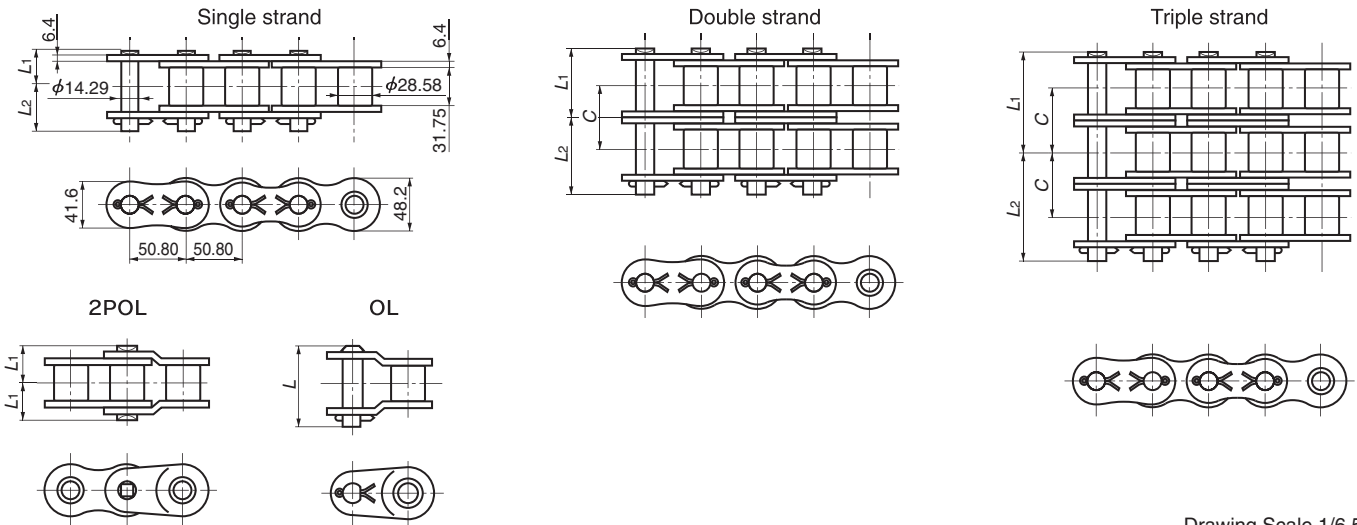

Drawing Scale 1/6.5

TSUBAKI Chain Number	Number of Strands	Pin Length L ₁ +L ₂	Dimensions L ₁	Dimensions L ₂	Offset Pin Length L	Transverse Pitch C	Pin Type	ANSI Standard Min. Tensile Strength kN{kgf}	Tsubaki Minimum Tensile Strength kN{kgf}	Tsubaki Average Tensile Strength kN{kgf}	Maximum Allowable Load kN{kgf}	Approximate Mass kg/m
RS160-1	1	68.7	31.85	36.85	70.2	58.5	Cotter pin	244.6{24942}	255 {26000}	279 {28500}	53.0{5400}	10.10
RS160-2	2	127.3	61.15	66.15	132.2			489.2{49885}	510 {52000}	559 {57000}	90.0{9180}	20.04
RS160-3	3	185.9	90.45	95.45	190.7			733.8{74827}	765 {78000}	838 {85500}	132{13500}	30.02
RS160-4	4	244.4	119.75	124.65	249.2		Riveting	-	1020{104000}	1120{114000}	175{17820}	40.06
RS160-5	5	303.0	149.05	153.95	307.7			-	1270{130000}	1400{142500}	207{21060}	49.89
RS160-6	6	361.6	178.3	183.3	366.2			-	1530{156000}	1680{171000}	244{24840}	59.93

Note: 1. Maximum allowable load when using a one-pitch offset link (OL) is 65% of the above. Two pitch offset links (2POL) can be used at 100% of the above values.
2. Number of links per unit = 60

■ RS160-1 Maximum Kilowatt Ratings Table (kW Ratings for Single Strand Chain)

Small Sprocket No. of Teeth	Small Sprocket Max rpm																							
	10	25	50	100	150	200	250	300	350	400	450	500	550	600	650	700	750	800	850	900	1000	1100	1200	1300
9	3.82	8.72	16.3	30.4	43.8	56.7	69.3	74.5	74.5	74.5	62.5	53.3	46.2	40.6	36.0	32.2	29.0	26.4	24.1	22.1	18.9	16.3	14.3	12.7
10	4.29	9.78	18.2	34.0	49.0	63.5	77.6	87.3	87.3	87.3	73.2	62.5	54.1	47.5	42.1	37.7	34.0	30.9	28.2	25.9	22.1	19.1	16.8	14.9
11	4.75	10.8	20.2	37.7	54.3	70.4	86.1	98.5	98.5	98.5	84.4	72.1	62.5	54.8	48.6	43.5	39.2	35.6	32.5	29.8	25.5	22.1	19.4	17.2
12	5.22	11.9	22.2	41.4	59.7	77.3	94.5	108	108	108	96.2	82.1	71.2	62.5	55.4	49.6	44.7	40.6	37.0	34.0	29.0	25.2	22.1	19.6
13	5.69	13.0	24.2	45.2	65.1	84.3	103	118	118	118	108	92.6	80.2	70.4	62.5	55.9	50.4	45.7	41.8	38.3	32.7	28.4	24.9	22.1
14	6.16	14.1	26.2	49.0	70.5	91.4	112	128	128	128	121	103	89.7	78.7	69.8	62.5	56.3	51.1	46.7	42.8	36.6	31.7	27.8	24.7
15	6.64	15.1	28.3	52.7	76.0	98.4	120	138	138	138	134	115	99.5	87.3	77.4	69.3	62.5	56.7	51.8	47.5	40.6	35.2	30.9	
16	7.12	16.2	30.3	56.6	81.5	106	129	148	148	148	148	148	126	110	96.2	85.3	76.3	68.8	62.5	57.0	52.3	44.7	38.7	34.0
17	7.60	17.3	32.4	60.4	87.0	113	138	162	162	162	162	162	138	120	105	93.4	83.6	75.4	68.4	62.5	57.3	48.9	42.4	37.2
18	8.09	18.4	34.4	64.2	92.5	120	146	173	177	177	177	177	151	131	115	102	91.1	82.1	74.5	68.1	62.5	53.3	46.2	40.6
19	8.57	19.6	36.5	68.1	98.1	127	155	183	192	192	192	192	164	142	124	110	98.8	89.0	80.8	73.8	67.7	57.8	50.1	44.0
20	9.06	20.7	38.6	72.0	104	134	164	193	207	207	207	207	177	153	134	119	107	96.2	87.3	79.7	73.2	62.5	54.1	47.5
21	9.55	21.8	40.6	75.9	109	142	173	204	220	220	220	220	190	165	145	128	115	103	93.9	85.8	78.7	67.2	58.3	51.1
22	10.0	22.9	42.7	79.8	115	149	182	214	231	231	231	231	204	177	155	138	123	111	101	92.0	84.4	72.1	62.5	
23	10.5	24.0	44.8	83.7	121	156	191	225	243	243	243	243	218	189	166	147	132	119	108	98.3	90.2	77.0	66.8	
24	11.0	25.2	47.0	87.6	126	164	200	236	254	254	254	254	232	201	177	157	140	126	115	105	96.2	82.1	71.2	
25	11.5	26.3	49.1	91.6	132	171	209	246	266	266	266	266	247	214	188	167	149	134	122	111	102	87.3	75.4	
26	12.0	27.4	51.2	95.5	138	178	218	257	277	277	277	277	262	227	199	177	158	143	129	118	108	92.6	80.2	
28	13.0	29.7	55.5	103	149	193	236	278	300	300	300	300	293	254	223	197	177	159	145	132	121	103	89.7	
30	14.0	32.0	59.8	112	161	208	254	300	325	325	325	325	325	281	247	219	196	177	160	146	134	115		
32	15.1	34.3	64.1	120	172	223	273	321	358	358	358	358	310	272	241	216	195	177	161	148	126			
35	16.6	37.8	70.6	132	190	246	300	354	407	409	409	409	354	311	276	247	223	202	185	169	134			
40	19.2	43.7	81.5	152	219	284	347	409	470	485	485	485	433	380	337	302	272	247	225	192				
45	21.7	49.6	92.6	173	249	322	394	464	533	551	551	551	517	454	402	360	312	260	202	141				

Note: 1. KW rating when using a one-pitch offset link (OL) is 65% of the above. Two pitch offset links (2POL) can be used at 100% of the above values.
2. Please contact a Tsubaki representative prior to use of kW ratings in the colored area of the table.

Multi-strand factor	Number of chain strands	Multi-strand factor	Number of chain strands	Multi-strand factor
	Double strand	1.7	Quintuple strand	3.9
	Triple strand	2.5	Sextuple strand	4.6
	Quadruple strand	3.3	-	-

Lubrication method	A	Manual lubrication or drip lubrication	Details on Pg. 193
	B	Oil bath or slinger disc lubrication	
	C	Forced pump lubrication	

Before Use | Standard Roller Chains | Lubrication-Free Roller Chains | Heavy Duty Roller Chains | Corrosion Resistant Roller Chains | Specialty Roller Chains | Sprockets | Pin Gear Drives | Accessories | Selection | Handling

RS160 Sprocket

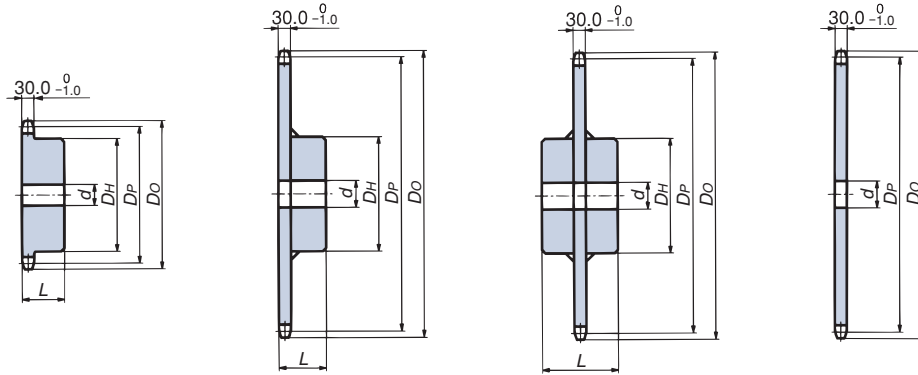

Mechanically machined 1B type Welded construction 1B type Welded construction 1C type 1A type

Number of Teeth	Pitch Circular Diameter (DP)	Sprocket Outer Diameter (DO)	1B type					1C type					1A type			Number of Teeth		
			Bore Diameter (d)		Hub		Approx. Mass (kg)	Material	Bore Diameter (d)		Hub		Approx. Mass (kg)	Material	Pilot Bore Diameter (d)		Approx. Mass (kg)	Material
			Pilot Bore Diameter	Maximum	Diameter (DH)	Length (L)			Pilot Bore Diameter	Maximum	Diameter (DH)	Length (L)						
10	164.39	187	33	70	105	63	6.3	Mechanically machined: machine-structural carbon steel							33	4.3	Machine-structural carbon steel	10
11	180.31	203	33	80	117	63	7.8								33	5.3		11
12	196.28	220	33	89	127	63	9.4								33	6.3		12
13	212.27	237	33	95	137	71	11.9								33	7.5		13
14	228.29	253	33	95	137	71	13.2								33	8.8		14
15	244.33	269	33	95	137	71	14.5								33	10.1		15
16	260.39	286	33	103	147	71	16.7								33	11.6		16
17	276.46	302	33	103	147	71	18.2								33	13.1		17
18	292.55	319	33	103	147	71	19.9								33	14.8		18
19	308.64	335	33	103	147	71	21.6								33	16.5		19
20	324.74	351	33	103	147	71	23.4								33	18.3		20
21	340.84	368	33	103	147	71	25.4								33	20.3		21
22	356.96	384	38	118	167	80	30.6			38	118	167	125	37.8	38	22.2		22
23	373.07	400	38	118	167	80	32.4		Welded construction: machine-structural carbon steel (teeth) and structural/rolled steel (hub)	38	118	167	125	39.6	38	24.0		23
24	389.19	416	38	118	167	80	34.6			38	118	167	125	41.8	38	26.2		24
25	405.32	433	38	118	167	80	37.0			38	118	167	125	44.2	38	28.6		25
26	421.45	449	38	118	167	80	39.5			38	118	167	125	46.6	38	31.0		26
27	437.58	465	38	118	167	80	42.0			38	118	167	125	49.1	38	33.5		27
28	453.72	481	38	118	167	80	44.6			38	118	167	125	51.7	38	36.1		28
30	485.99	514	38	118	167	100	53.5	38		118	167	125	57.2	38	41.6	30		
32	518.28	546	38	118	167	100	59.5	38		118	167	125	63.0	38	47.4	32		
34	550.57	579	38	118	167	100	65.8	38		118	167	125	69.3	38	53.7	34		
35	566.72	595	38	118	167	100	69.2	38		118	167	135	74.2	38	57.0	35		
36	582.86	611	38	118	167	100	72.6	38	118	167	135	77.6	38	60.3	36			
38	615.17	644	38	118	167	100	80.1	38	118	167	135	84.6	38	67.4	38			
40	647.47	676	38	132	187	121	94.4	38	132	187	150	99.7	38	74.8	40			
42	679.78	708	38	132	187	121	102.2	38	132	187	150	107.5	38	82.6	42			
45	728.25	757	38	132	187	121	115.2	38	132	187	150	119.9	38	95.0	45			
48	776.72	806	38	132	187	121	128.5	38	132	187	150	133.2	38	108.4	48			
50	809.04	838	38	132	187	121	137.9	38	132	187	150	142.5	38	117.7	50			
54	873.68	903	38	132	187	121	157.7	38	132	187	150	162.4	38	137.5	54			
60	970.65	1000	38	132	187	121	190.7	38	132	187	160	197.0	38	170.1	60			

- Note: 1. Maximum bore diameter is the typical range. Determine bore diameter and key bearing pressure based on general mechanical design.
 2. Models in shaded areas have hardened teeth.
 3. For sprockets without hardened teeth, the Strong Series of sprocket with hardened teeth can be made-to-order.
 4. Models with approximate masses in bold have one hanging hole processed.
 See the diagram on the right for information.

Sprocket Number

RS160 -1B 15T



Hanging Hole Dimensions

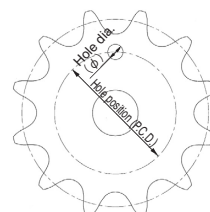

The phase relationship between the hanging hole and teeth may vary.

No. of teeth	1B, 1C, 1A Type bore dia. (φ40) Hole position (P.C.D.)	No. of teeth	1B, 1C, 1A Type bore dia. (φ40) Hole position (P.C.D.)
23	261	36	471
24	277	38	503
25	293	40	535
26	309	42	568
27	326	45	616
28	342	48	665
30	374	50	697
32	406	54	762
34	438	60	859
35	455		

RS180

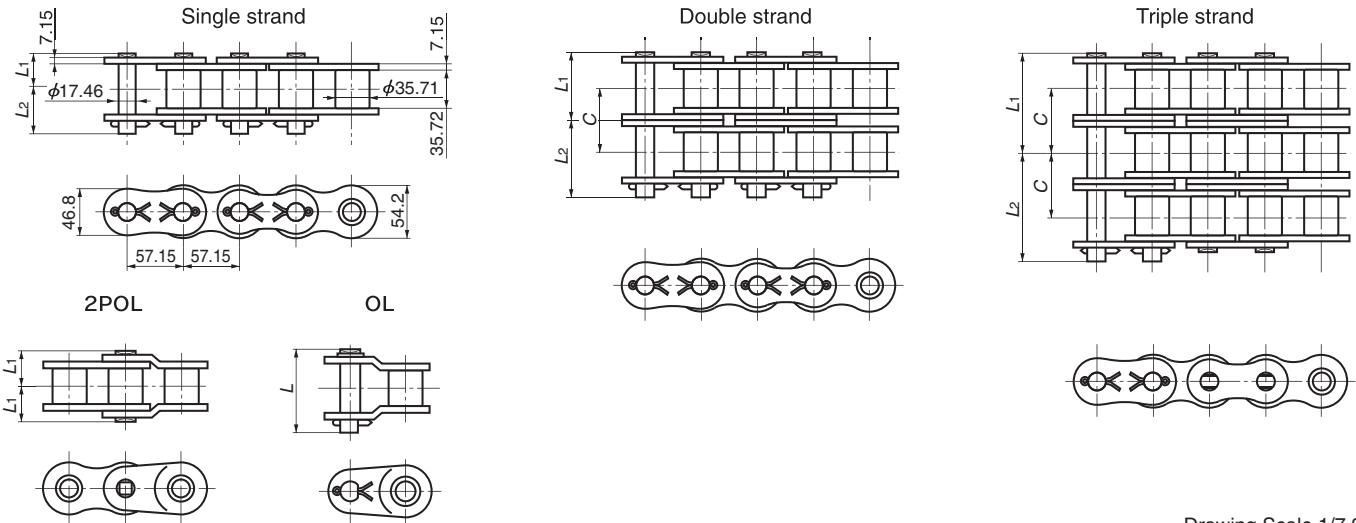

Drawing Scale 1/7.2

TSUBAKI Chain Number	Number of Strands	Pin Length L ₁ +L ₂	Dimensions L ₁	Dimensions L ₂	Offset Pin Length L	Transverse Pitch C	Pin Type	ANSI Standard Min. Tensile Strength kN{kgf}	Tsubaki Minimum Tensile Strength kN{kgf}	Tsubaki Average Tensile Strength kN{kgf}	Maximum Allowable Load kN{kgf}	Approximate Mass kg/m
RS180-1	1	78.1	35.65	42.45	80.6	65.8	Cotter pin	308.2{31428}	336 {34300}	370 {37700}	60.8{6200}	13.45
RS180-2	2	144.1	68.75	75.35	151.1			616.4{62885}	673 {68600}	739 {75400}	103{10540}	26.52
RS180-3	3	210.2	101.7	108.5	216.9			924.6{94283}	1010{102900}	1110{113100}	152{15500}	38.22
RS180-4	4	276.1	134.65	141.45	282.8		–	1350{137200}	1480{150800}	201{20460}	50.90	
RS180-5	5	342.0	167.6	174.4	348.6		–	1680{171500}	1850{188500}	237{24180}	63.59	
RS180-6	6	407.9	200.55	207.35	414.4		–	2020{205800}	2180{226200}	280{28520}	76.27	

Note: 1. Maximum allowable load when using a one-pitch offset link (OL) is 65% of the above. Two pitch offset links (2POL) can be used at 100% of the above values.
2. Number of links per unit = 54

■ RS180-1 Maximum Kilowatt Ratings Table (kW Ratings for Single Strand Chain)

Small Sprocket No. of Teeth	Small Sprocket Max rpm																						
	10	25	50	100	150	200	250	300	350	400	450	500	550	600	650	700	750	800	850	900	950	1000	1050
9	4.94	11.3	21.0	39.2	56.5	73.2	89.4	90.8	81.9	68.6	58.6	50.8	44.6	39.5	35.4	31.9	29.0	26.4	24.3	22.4	20.7	19.3	18.0
10	5.53	12.6	23.5	43.9	63.3	82.0	100	102	95.9	80.4	68.6	59.5	52.2	46.3	41.4	37.4	33.9	31.0	28.4	26.2	24.3	22.6	21.0
11	6.13	14.0	26.1	48.7	70.1	90.9	111	113	111	92.7	79.2	68.6	60.2	53.4	47.8	43.1	39.1	35.7	32.8	30.2	28.0	26.0	24.3
12	6.73	15.4	28.7	53.5	77.0	100	122	126	126	106	90.2	78.2	68.6	60.9	54.5	49.1	44.6	40.7	37.4	34.4	31.9	29.6	27.6
13	7.34	16.7	31.3	58.3	84.0	109	133	142	142	119	102	88.2	77.4	68.6	61.4	55.4	50.3	45.9	42.1	38.8	36.0	33.4	
14	7.95	18.1	33.9	63.2	91.0	118	144	159	159	133	114	98.5	86.5	76.7	68.6	61.9	56.2	51.3	47.1	43.4	40.2	37.4	
15	8.57	19.5	36.5	68.1	98.0	127	155	176	176	148	126	109	95.9	85.1	76.1	68.6	62.3	56.9	52.2	48.1	44.6	41.4	
16	9.19	21.0	39.1	73.0	105	136	166	191	191	163	139	120	106	93.7	83.9	75.6	68.6	62.7	57.5	53.0	49.1	45.6	
17	9.81	22.4	41.8	77.9	112	145	178	201	201	178	152	132	116	103	91.8	82.8	75.2	68.6	63.0	58.1	53.8		
18	10.4	23.8	44.4	82.9	119	155	189	216	216	194	166	144	126	112	100	90.2	81.9	74.8	68.6	63.3	58.6		
19	11.1	25.2	47.1	87.9	127	164	200	229	229	211	180	156	137	121	109	97.8	88.8	81.1	74.4	68.6	63.5		
20	11.7	26.7	49.8	92.9	134	173	212	243	243	227	194	168	148	131	117	106	95.9	87.6	80.4	74.1	68.6		
21	12.3	28.1	52.5	97.9	141	183	223	256	256	245	209	181	159	141	126	114	103	94.2	86.5	79.7	73.8		
22	13.0	29.6	55.2	103	148	192	235	269	269	262	224	194	170	151	135	122	111	101	92.7	85.5			
23	13.6	31.0	57.9	108	156	202	246	282	282	280	239	208	182	162	145	130	118	108	99.1	91.4			
24	14.2	32.5	60.6	113	163	211	258	299	299	299	255	221	194	172	154	139	126	115	106	97.4			
25	14.9	33.9	63.3	118	170	221	270	318	318	318	271	235	206	183	164	148	134	122	112	104			
26	15.5	35.4	66.1	123	178	230	281	331	337	337	288	249	219	194	174	157	142	130	119				
28	16.8	38.4	71.6	134	192	249	305	359	377	377	322	279	245	217	194	175	159	145	133				
30	18.1	41.3	77.1	144	207	269	328	387	418	418	357	309	271	241	215	194	176	161	148				
32	19.4	44.3	82.7	154	222	288	352	415	448	448	393	341	299	265	237	214	194	177					
35	21.4	48.8	91.1	170	245	317	388	457	494	494	449	390	342	303	271	245	217	164					
40	24.7	56.4	105	196	283	366	448	504	504	504	463	429	391	347	297	242	182						
45	28.1	64.0	119	223	321	416	509	551	551	551	507	471	431	383	329	269	202						

Note: 1. KW rating when using a one-pitch offset link (OL) is 65% of the above. Two pitch offset links (2POL) can be used at 100% of the above values.
2. Please contact a Tsubaki representative prior to use of kW ratings in the colored area of the table.

Multi-strand factor	Number of chain strands	Multi-strand factor	Number of chain strands	Multi-strand factor
	Double strand	1.7	Quintuple strand	3.9
	Triple strand	2.5	Sextuple strand	4.6
	Quadruple strand	3.3	–	–

Lubrication method	A	Manual lubrication or drip lubrication	Details on Pg. 193
	B	Oil bath or slinger disc lubrication	
	C	Forced pump lubrication	

RS180 Sprocket

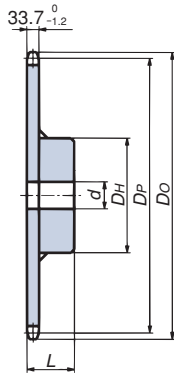

Welded construction
1B type

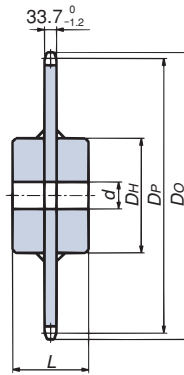

Welded construction
1C type

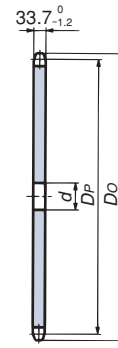

1A type

Number of Teeth	Pitch Circular Diameter (D _p)	Sprocket Outer Diameter (D _o)	1B type					1C type					1A type			Number of Teeth			
			Bore Diameter (d)		Hub		Approx. Mass (kg)	Material	Bore Diameter (d)		Hub		Approx. Mass (kg)	Material	Pilot Bore Diameter (d)		Approx. Mass (kg)	Material	
			Pilot Bore Diameter	Maximum	Diameter (D _H)	Length (L)			Pilot Bore Diameter	Maximum	Diameter (D _H)	Length (L)							
11	202.85	229	43	75	110	55	8.6									43	7.0	Machine-structural carbon steel	11
12	220.81	248	43	85	130	65	11.6									43	8.5		12
13	238.81	266	43	95	150	75	15.6									43	10.1		13
14	256.83	285	43	105	170	80	19.7									43	11.9		14
15	274.87	303	43	110	180	80	22.6									43	13.8		15
16	292.94	322	43	110	180	80	24.6									43	15.8		16
17	311.02	340	43	115	180	80	26.8									43	17.9		17
18	329.12	358	43	115	180	80	29.2									43	20.2		18
19	347.21	377	43	115	180	80	31.6									43	22.7		19
20	365.33	395	43	115	180	80	34.2									43	25.2		20
21	383.45	413						63	120	190	85	37.8				63	27.5		21
22	401.57	432						63	120	190	85	40.4				63	30.0		22
23	419.70	450						63	120	200	90	45.7				63	33.0		23
24	437.84	468						63	125	200	90	48.8				63	36.1		24
25	455.99	487						63	125	200	90	52.0				63	39.4		25
26	474.13	505						63	125	200	90	55.4				63	42.8		26
27	492.28	523						63	125	200	90	58.9				63	46.3		27
28	510.43	542						63	125	200	90	62.6				63	50.0		28
30	546.74	578						63	135	220	110	78.7				63	57.7		30
32	583.06	615						63	135	220	110	86.9				63	65.9		32
34	619.39	651						63	135	220	110	95.8				63	74.8		34
35	637.55	669						63	135	220	110	100.4				63	79.4		35
36	655.72	688						63	135	220	110	105.1				63	84.1		36
38	692.06	724						63	135	220	110	115.0				63	94.0		38
40	728.41	760						63	150	240	125	134.7				63	104.5		40
42	764.75	797						63	150	240	125	145.8				63	115.6		42
45	819.28	852						63	150	240	125	163.3				63	133.1		45
48	873.81	906						63	150	240	125	182.1				63	151.8		48
50	910.17	943						63	150	240	125	195.3				63	165.1		50
54	982.89	1016						63	150	240	125	223.3				63	193.1		54
60	1091.98	1125						63	150	240	125	269.5				63	239.2		60

Note: 1. Maximum bore diameter is the typical range. Determine bore diameter and key bearing pressure based on general mechanical design.
2. Models with approximate masses in bold have one hanging hole processed. See the diagram on the right for information.

Sprocket Number

RS180 -1B 15T

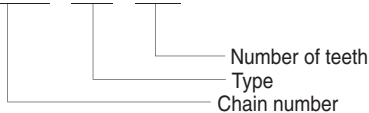

Hanging Hole Dimensions

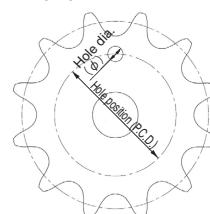

The phase relationship between the hanging hole and teeth may vary.

No. of teeth	1B, 1C, 1A Type bore dia. (φ40) Hole position (P.C.D.)	No. of teeth	1B, 1C, 1A Type bore dia. (φ40) Hole position (P.C.D.)
22	276	35	512
23	294	36	531
24	313	38	567
25	331	40	603
26	349	42	640
27	367	45	694
28	385	48	749
30	422	50	785
32	458	54	858
34	464	60	967

RS200

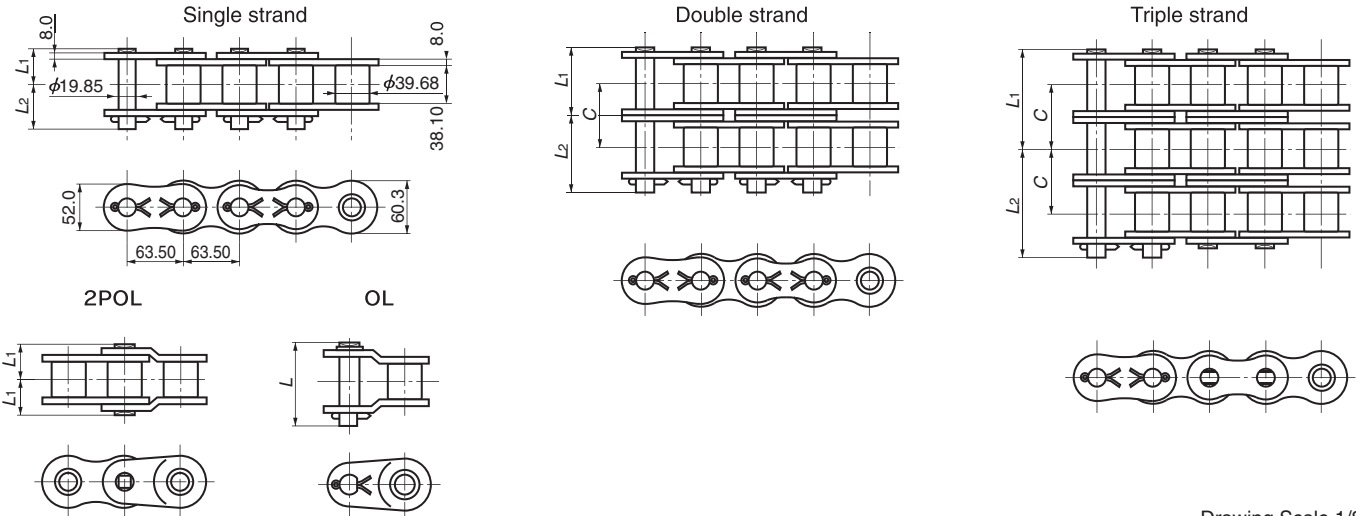

Drawing Scale 1/8

TSUBAKI Chain Number	Number of Strands	Pin Length L ₁ +L ₂	Dimensions L ₁	Dimensions L ₂	Offset Pin Length L	Transverse Pitch C	Pin Type	ANSI Standard Min. Tensile Strength kN{kgf}	Tsubaki Minimum Tensile Strength kN{kgf}	Tsubaki Average Tensile Strength kN{kgf}	Maximum Allowable Load kN{kgf}	Approximate Mass kg/m
RS200-1	1	83.8	39.0	44.8	87.3	71.6	Cotter pin	381.7 {38923}	427 {43500}	471 {48000}	71.6{7300}	16.49
RS200-2	2	155.5	74.85	80.65	161.2			763.4 {77845}	853 {87000}	941 {96000}	122{12410}	32.63
RS200-3	3	227.2	110.75	116.45	233.0		Riveting	1145.1{116768}	1280{130500}	1410{144000}	179{18250}	49.02
RS200-4	4	298.9	146.6	152.3	304.7			—	1710{174000}	1880{192000}	236{24090}	65.16
RS200-5	5	370.6	182.4	188.2	376.3			—	2130{217500}	2350{240000}	279{28470}	81.32
RS200-6	6	442.3	218.25	224.05	448.0			—	2560{261000}	2820{288000}	329{33580}	97.59

Note: 1. Maximum allowable load when using a one-pitch offset link (OL) is 65% of the above. Two pitch offset links (2POL) can be used at 100% of the above values.
2. Number of links per unit = 48

■ RS200-1 Maximum Kilowatt Ratings Table (kW Ratings for Single Strand Chain)

Small Sprocket No. of Teeth	Small Sprocket Max rpm																			
	10	15	20	30	40	50	70	100	150	200	250	300	350	400	450	500	550	600	650	
	A					B					C									
9	6.46	9.30	12.1	17.4	22.5	27.5	37.2	51.3	73.9	95.73	108	108	108	89.1	74.7	63.8	55.3	48.5	43.0	
10	7.24	10.4	13.5	19.5	25.2	30.8	41.7	57.5	82.8	107	122	122	122	104	87.5	74.7	64.7	56.8	50.4	
11	8.02	11.6	15.0	21.6	27.9	34.1	46.2	63.7	91.8	119	135	135	135	120	101	86.1	74.7	65.5	58.1	
12	8.81	12.7	16.4	23.7	30.7	37.5	50.8	70.0	101	131	148	148	148	137	115	98.2	85.1	74.7		
13	9.61	13.8	17.9	25.8	33.5	40.9	55.4	76.3	110	142	161	161	161	155	130	111	95.9	84.2		
14	10.4	15.0	19.4	28.0	36.2	44.3	60.0	82.7	119	154	175	175	175	173	145	124	107	94.1		
15	11.2	16.2	20.9	30.1	39.0	47.7	64.6	89.1	128	166	192	192	192	192	161	137	119	104		
16	12.0	17.3	22.4	32.3	41.9	51.2	69.3	95.5	138	178	211	211	211	211	177	151	131	115		
17	12.8	18.5	24.0	34.5	44.7	54.6	74.0	102	147	190	231	231	231	231	194	166	143	126		
18	13.7	19.7	25.5	36.7	47.5	58.1	78.7	108	156	202	247	252	252	252	211	180	156	137		
19	14.5	20.8	27.0	38.9	50.4	61.6	83.4	115	166	215	262	273	273	273	229	196	170	149		
20	15.3	22.0	28.5	41.1	53.3	65.1	88.2	122	175	227	277	290	290	290	247	211	183			
21	16.1	23.2	30.1	43.3	56.2	68.6	92.9	128	185	239	292	305	305	305	266	227	197			
22	17.0	24.4	31.6	45.6	59.0	72.2	97.7	135	194	251	307	321	321	321	285	244	211			
23	17.8	25.6	33.2	47.8	62.0	75.7	103	141	204	264	322	337	337	337	305	260	226			
24	18.6	26.8	34.8	50.1	64.9	79.3	107	148	213	276	338	353	353	353	325	278	241			
25	19.5	28.0	36.3	52.3	67.8	82.9	112	155	223	289	353	369	369	369	346	295	256			
26	20.3	29.3	37.9	54.6	70.7	86.5	117	161	232	301	368	385	385	385	367	313	271			

Note: 1. KW rating when using a one-pitch offset link (OL) is 65% of the above. Two pitch offset links (2POL) can be used at 100% of the above values.
2. Please contact a Tsubaki representative prior to use of kW ratings in the colored area of the table.

Multi-strand factor	Number of chain strands	Multi-strand factor	Number of chain strands	Multi-strand factor
	Double strand	1.7	Quintuple strand	3.9
	Triple strand	2.5	Sextuple strand	4.6
	Quadruple strand	3.3	—	—

Lubrication method	A	Manual lubrication or drip lubrication	Details on Pg. 193
	B	Oil bath or slinger disc lubrication	
	C	Forced pump lubrication	

RS240

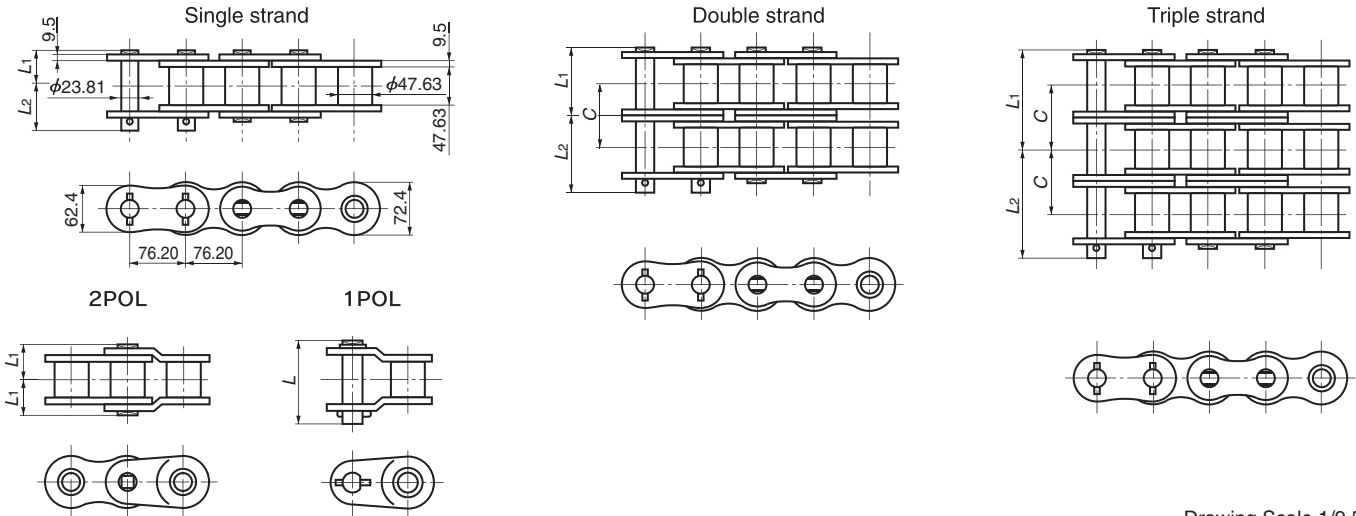

Drawing Scale 1/9.5

TSUBAKI Chain Number	Number of Strands	Pin Length L ₁ +L ₂	Dimensions L ₁	Dimensions L ₂	Offset Pin Length L	Transverse Pitch C	Pin Type	ANSI Standard Min. Tensile Strength kN{kgf}	Tsubaki Minimum Tensile Strength kN{kgf}	Tsubaki Average Tensile Strength kN{kgf}	Maximum Allowable Load kN{kgf}	Approximate Mass kg/m
RS240-1	1	103.4	47.9	55.5	106.7	87.8	Riveting	550.4{56125}	623 {63500}	686 {70000}	99.0{10100}	24.5
RS240-2	2	191.3	91.9	99.4	198.4			1100.8{112250}	1250{127000}	1370{140000}	168{17170}	48.1
RS240-3	3	279.0	135.85	143.15	286.3			1651.2{168376}	1870{190500}	2060{210000}	248{25250}	71.6
RS240-4	4	367.1	179.8	187.3	374.2			-	2490{254000}	2750{280000}	327{33330}	95.1
RS240-5	5	455.0	223.75	231.25	462.0			-	3110{317500}	3430{350000}	386{39390}	118.6
RS240-6	6	542.8	267.7	275.1	550.1			-	3740{381000}	4120{420000}	456{46460}	142.1

Note: 1. Maximum allowable load when using a one-pitch offset link (OL) is 65% of the above. Two pitch offset links (2POL) can be used at 100% of the above values.
2. Number of links per unit = 40

■ RS240-1 Maximum Kilowatt Ratings Table (kW Ratings for Single Strand Chain)

Small Sprocket No. of Teeth	Small Sprocket Max rpm																			
	5	10	15	20	25	30	40	50	60	80	100	125	150	175	200	250	300	350	400	450
	A						B												C	
9	5.74	10.7	15.4	20.0	24.4	28.8	37.3	45.6	53.7	69.6	85.1	104	123	141	159	159	159	126	103	86.5
10	6.43	12.0	17.3	22.4	27.4	32.3	41.8	51.1	60.2	78.0	95.4	117	137	158	178	183	183	148	121	101
11	7.13	13.3	19.2	24.8	30.4	35.8	46.3	56.7	66.8	86.5	106	129	152	175	197	202	202	170	140	116
12	7.83	14.6	21.1	27.3	33.4	39.3	50.9	62.2	73.3	95.0	116	142	167	192	217	222	222	194	159	
13	8.54	15.9	23.0	29.7	36.4	42.8	55.5	67.9	80.0	104	127	155	182	210	236	242	242	219	179	
14	9.25	17.3	24.9	32.2	39.4	46.4	60.1	73.5	86.6	112	137	168	198	227	256	263	263	245	200	
15	9.97	18.6	26.8	34.7	42.4	50.0	64.8	79.2	93.3	121	148	181	213	245	276	283	283	271	222	
16	10.7	19.9	28.7	37.2	45.5	53.6	69.5	84.9	100	130	158	194	228	262	296	299	299	269	245	
17	11.4	21.3	30.7	39.7	48.6	57.2	74.2	90.7	107	138	169	207	244	280	300	300	300	281	268	
18	12.1	22.7	32.6	42.3	51.7	60.9	78.9	96.4	114	147	180	220	259	298	303	303	303	291	281	
19	12.9	24.0	34.6	44.8	54.8	64.6	83.6	102	120	156	191	233	275	316	317	317	317	304	293	
20	13.6	25.4	36.6	47.4	57.9	68.2	88.4	108	127	165	202	246	290	330	330	330	330	316	304	
21	14.3	26.8	38.5	49.9	61.0	71.9	93.2	114	134	174	213	260	306	345	345	345	345	328	314	
22	15.1	28.1	40.5	52.5	64.2	75.6	98.0	120	141	183	223	273	322	346	346	346	346	342	339	315
23	15.8	29.5	42.5	55.1	67.3	79.3	103	126	148	192	234	287	338	370	370	370	359	350	334	
24	16.6	30.9	44.5	57.7	70.5	83.1	108	132	155	201	246	300	354	396	396	396	376	360		
25	17.3	32.3	46.5	60.3	73.7	86.8	112	137	162	210	257	314	370	410	410	410	388	370		
26	18.1	33.7	48.5	62.9	76.9	90.6	117	143	169	219	268	327	386	418	418	418	397	380		

Note: 1. KW rating when using a one-pitch offset link (OL) is 65% of the above. Two pitch offset links (2POL) can be used at 100% of the above values.
2. Please contact a Tsubaki representative prior to use of kW ratings in the colored area of the table.

Multi-strand factor	Number of chain strands	Multi-strand factor	Number of chain strands	Multi-strand factor
	Double strand	1.7	Quintuple strand	3.9
	Triple strand	2.5	Sextuple strand	4.6
	Quadruple strand	3.3	-	-

Lubrication method	A	Manual lubrication or drip lubrication	Details on Pg. 193
	B	Oil bath or slinger disc lubrication	
	C	Forced pump lubrication	

RS240 Sprocket

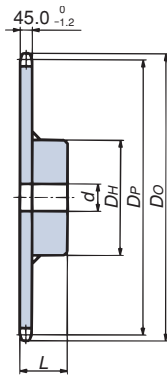

Welded construction
1B type

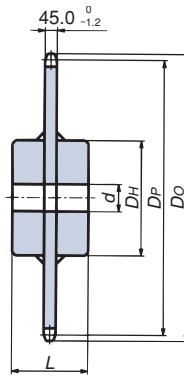

Welded construction
1C type

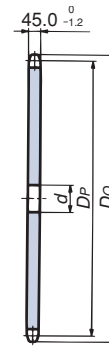

1A type

Number of Teeth	Pitch Circular Diameter (D _p)	Sprocket Outer Diameter (D _o)	1B type					1C type					1A type			Number of Teeth		
			Bore Diameter (d)		Hub		Approx. Mass (kg)	Material	Bore Diameter (d)		Hub		Approx. Mass (kg)	Material	Pilot Bore Diameter (d)		Approx. Mass (kg)	Material
			Pilot Bore Diameter	Maximum	Diameter (D _H)	Length (L)			Pilot Bore Diameter	Maximum	Diameter (D _H)	Length (L)						
11	270.47	305	43	90	150	75	21.3	Welded construction: machine-structural carbon steel (teeth) and structural rolled steel (hub)	63	140	230	110	52.4	structural rolled steel (teeth and hub)	Welded construction: Machine-structural carbon steel	43	17.1	11
12	294.41	330	43	100	170	85	27.8		63	140	230	110	57.2		63	37.3	16	
13	318.41	355	43	120	200	100	37.7		63	145	230	110	62.3		63	42.4	17	
14	342.44	380	43	130	210	110	46.0		63	145	230	110	67.8		63	47.9	18	
15	366.50	404							63	150	240	120	78.7		63	53.6	19	
16	390.59	429							63	150	240	120	84.3		63	59.2	20	
17	414.70	453							63	155	240	120	90.7		63	65.6	21	
18	438.82	478							63	155	240	120	97.4		63	72.3	22	
19	462.95	502							63	160	260	140	116.9		63	79.4	23	
20	487.11	527							63	160	260	140	124.3		63	86.8	24	
21	511.26	551							63	160	260	140	132.0		63	94.5	25	
22	535.43	576							63	160	260	140	140.1		63	102.6	26	
23	559.61	600							63	160	260	140	148.5		63	111.0	27	
24	583.79	625							63	160	260	140	157.1		63	119.6	28	
25	607.98	649							63	165	260	140	175.5		63	138.0	30	
26	632.17	673							63	165	260	140	195.1		63	157.6	32	
27	656.37	698							63	165	260	140	216.1		63	178.5	34	
28	680.57	722							63	165	260	140	227.0		63	189.4	35	
30	728.99	771							63	165	260	140	238.3		63	200.8	36	
32	777.42	819							63	165	260	140	261.8		63	224.3	38	
34	825.86	868							68	170	270	140	289.3		68	248.9	40	
35	850.07	892							68	170	270	140	315.4		68	275.2	42	
36	874.30	917							68	170	270	140	357.0		68	316.8	45	
38	922.75	965							68	170	270	140	401.6		68	361.4	48	
40	971.21	1014							68	170	270	140	432.9		68	392.7	50	
42	1019.67	1063						68	170	270	140	499.5	68	459.2	54			
45	1092.37	1135																
48	1165.08	1208																
50	1213.56	1257																
54	1310.52	1354																
60	1455.98	1500																

Note: 1. Maximum bore diameter is the typical range. Determine bore diameter and key bearing pressure based on general mechanical design.
 2. Models with approximate masses in bold have one hanging hole processed.
 See the diagram on the right for information.

Sprocket Number

RS240 -1B 14T

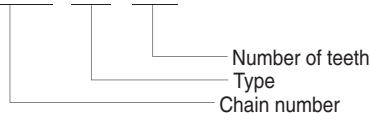

Hanging Hole Dimensions

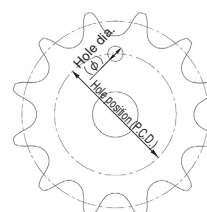

The phase relationship between the hanging hole and teeth may vary.

No. of teeth	1B, 1C, 1A Type bore dia. (φ40) Hole position (P.C.D.)	No. of teeth	1B, 1C, 1A Type bore dia. (φ40) Hole position (P.C.D.)
20	355	32	635
21	378	34	681
22	401	35	704
23	424	36	726
24	447	38	773
25	470	40	821
26	494	42	867
27	517	45	938
28	540	48	1009
30	587	50	1054
		54	1148
		60	1291

RF320-T, RF400-T

RF320-T

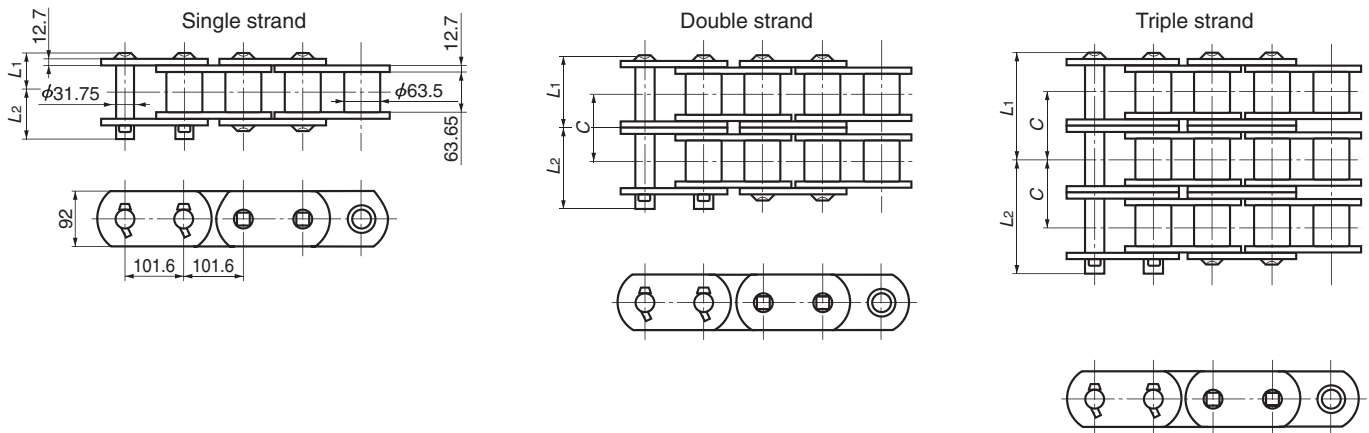

Drawing Scale: 1/12.7

TSUBAKI Chain Number	Number of Strands	Pin Length L_1+L_2	Dimensions L_1	Dimensions L_2	Offset Pin Length L	Transverse Pitch C	Pin Type	Tsubaki Minimum Tensile Strength kN{kgf}	Tsubaki Average Tensile Strength kN{kgf}	Maximum Allowable Load kN{kgf}	Approximate Mass kg/m
RF320-T-1	1	141.4	63.8	77.6	—	117.1	Riveting	1000{102000}	1150{117000}	123{12500}	47.6
RF320-T-2	2	258.7	122.4	136.3	—			2000{204000}	2290{234000}	208{21250}	94.6
RF320-T-3	3	375.9	181.05	194.85	—			3000{306000}	3440{351000}	306{31250}	141.5
RF320-T-4	4	493.2	239.65	253.55	—			4000{408000}	4590{468000}	405{41250}	188.5

Note 1. Number of links per unit = 30

RF400-T

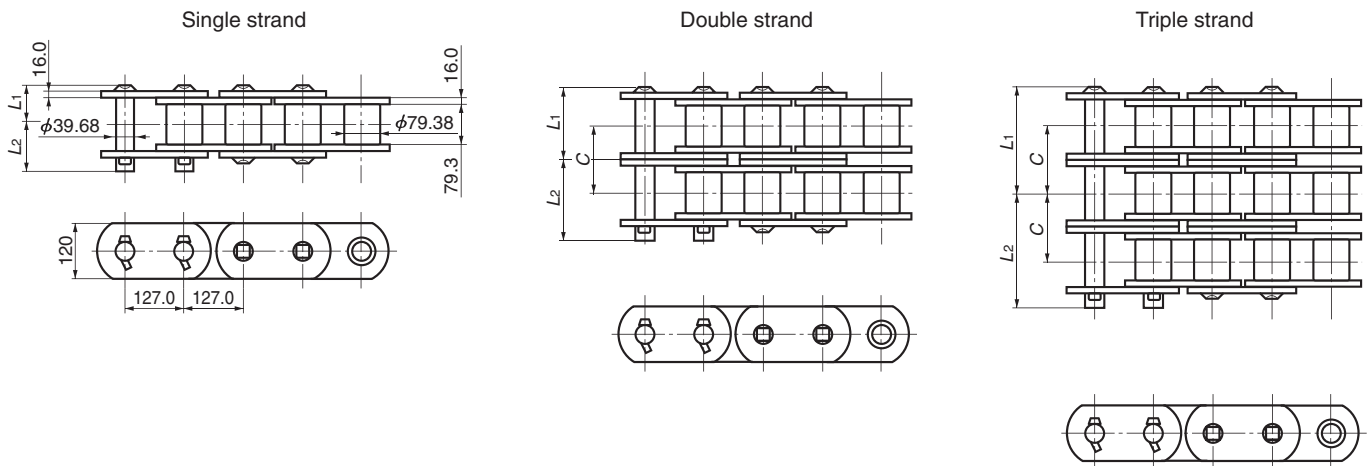

Drawing Scale 1/16

TSUBAKI Chain Number	Number of Strands	Pin Length L_1+L_2	Dimensions L_1	Dimensions L_2	Offset Pin Length L	Transverse Pitch C	Pin Type	Tsubaki Minimum Tensile Strength kN{kgf}	Tsubaki Average Tensile Strength kN{kgf}	Maximum Allowable Load kN{kgf}	Approximate Mass kg/m
RF400-T-1	1	172.3	79.65	92.65	—	146.8	Riveting	1730{176000}	1950{199000}	188{19200}	83.9
RF400-T-2	2	319.0	153.05	165.95	—			3450{352000}	3900{398000}	320{32640}	166.8
RF400-T-3	3	465.7	226.45	239.25	—			5180{528000}	5850{597000}	471{48000}	249.7
RF400-T-4	4	612.3	299.8	312.5	—			6900{704000}	7810{796000}	621{63360}	332.7

Note 1. Number of links per unit = 24

BS/DIN Standard RS Roller Chain

Tsubaki presents its 4th generation BS/DIN standard RS Roller Chain, GT4 WINNER.

GT4 WINNER was crafted with ultimate wear life in mind, a proven benefit for customers looking for real savings in chain maintenance & product replacement. Tsubaki BS/DIN European Standard chain is available in chain sizes from RS05B to RS56B. Single, double, and triple strand chains are available.



1 Lube Groove (LG) Solid Bush

Thanks to Tsubaki's own innovative fabrication technology, we have developed a new seamless solid bush. This high precision solid bush with special lube grooves (LG) improves lubrication retention, greatly extending the original wear life of the chain.

※ LG solid bushes (PAT.) are available for 16B to 24B



Lube Groove (LG) Solid Bush

2 Ring Coin (RC) Processing

Residual stress generated from a groove around the connecting plate hole eliminates strength reduction caused by the gap between the pin and the plate necessary for connecting and disconnecting. With this groove, the connecting link achieves the same strength as the chain itself.

※ RC processing is available for 08B to 40B



Ring Coin (RC) Processing

3 Center Sink Rivet

Tsubaki's chains can easily be disassembled thanks to our unique center sink rivet head, reducing the time needed for chain maintenance.

An additional benefit is that should the chain be inadvertently overloaded, the markings on the rivet head will identify where pin rotation has occurred, giving a clear indication of chain overload.

※ Center sink rivets are available for 08B to 16B



Center Sink Rivet

Extremely Long Wear Life

Wear Elongation Comparison

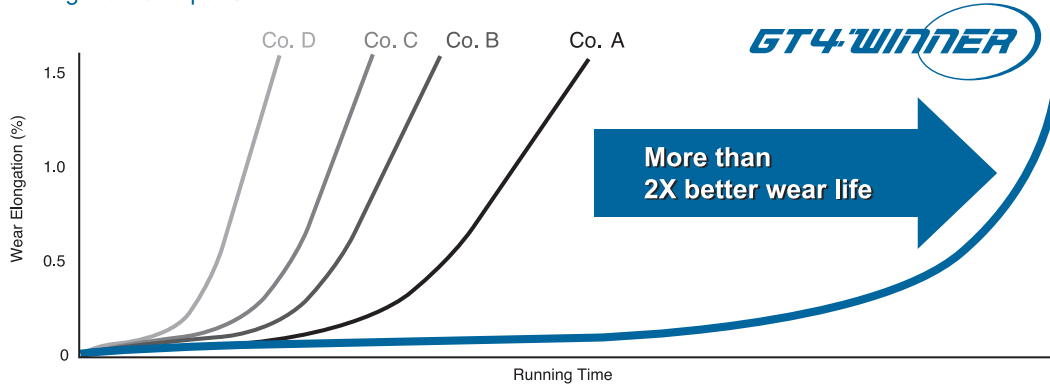

CO2 Reduction

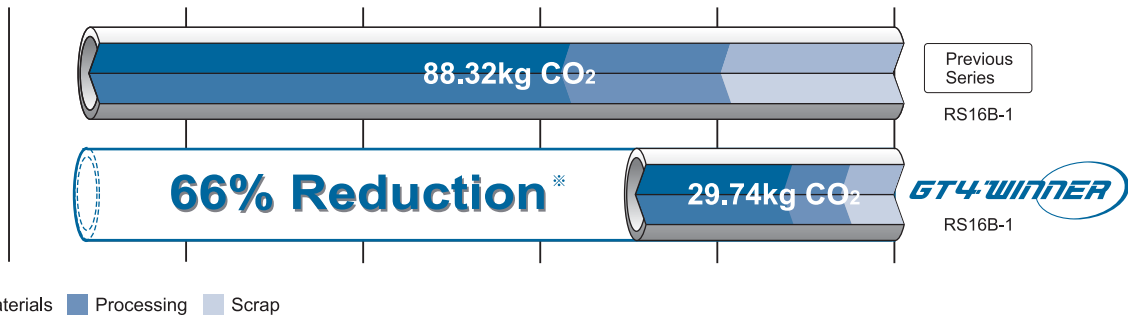

With its focus on manufacturing chain with a substantially longer wear life, Tsubaki is helping to create an environment in harmony with our planet. Less frequent chain replacement results in less consumption of resources and contributes to significantly lower CO2 emissions.

※ Results of RS Roller Chain (16B-1) LCA inventory analysis.

Quick and Accurate Selection

We are listing our new maximum allowable loads, as well as our new maximum kilowatt ratings table. This will allow quicker and more accurate chain selection.

Lubrication Type Small Sprocket No. of Teeth	Small Sprocket Max rpm																					
	10	25	50	100	150	200	300	400	500	600	700	800	900	1000	1100	1200	1400	1600	1800	2000	2200	
9	A I			A II				B														
9	0.35	0.81	1.51	2.82	4.06	5.25	7.57	9.81	12.0	14.1	16.2	15.1	12.7	10.8	9.39	8.24	6.54	5.35	4.48	3.83	3.3	
10	0.40	0.91	1.69	3.16	4.54	5.89	8.48	11.0	13.4	15.8	18.2	17.7	14.9	12.7	11.0	9.65	7.66	6.27	5.25	4.48	3.8	
11	0.44	1.00	1.87	3.50	5.04	6.53	9.40	12.2	14.9	17.5	20.2	20.4	17.1	14.6	12.7	11.1	8.83	7.23	6.06	5.17	4.4	
12	0.48	1.10	2.06	3.84	5.53	7.17	10.3	13.4	16.4	19.3	22.1	23.3	19.5	16.7	14.5	12.7	10.1	8.24	6.90	5.89	5.1	
13	0.53	1.20	2.24	4.19	6.03	7.82	11.3	14.6	17.8	21.0	24.1	26.3	22.0	18.8	16.3	14.3	11.3	9.29	7.78	6.65	5.7	
14	0.57	1.30	2.43	4.54	6.54	8.47	12.2	15.8	19.3	22.8	26.1	29.4	24.6	21.0	18.2	16.0	12.7	10.4	8.70	7.43	6.4	
15	0.62	1.40	2.62	4.89	7.04	9.12	13.1	17.0	20.8	24.5	28.2	31.8	27.3	23.3	20.2	17.7	14.1	11.5	9.65	8.24	7.1	
16	0.66	1.51	2.81	5.24	7.55	9.78	14.1	18.3	22.3	26.3	30.2	34.1	30.1	25.7	22.2	19.5	15.5	12.7	10.6	9.08	7.8	
17	0.70	1.61	3.00	5.60	8.06	10.4	15.0	19.5	23.8	28.1	32.2	36.4	32.9	28.1	24.4	21.4	17.0	13.9	11.6	9.94	8.6	
18	0.75	1.71	3.19	5.95	8.57	11.1	16.0	20.7	25.3	29.9	34.3	38.7	35.9	30.6	26.5	23.3	18.5	15.1	12.7	10.8	9.5	
19	0.79	1.81	3.38	6.31	9.09	11.8	17.0	22.0	26.9	31.7	36.4	41.0	38.9	33.2	28.8	25.3	20.1	16.4	13.8	11.7	10	
20	0.84	1.92	3.57	6.67	9.61	12.4	17.9	23.2	28.4	33.5	38.4	43.3	42.0	35.9	31.1	27.3	21.7	17.7	14.9	12.7	11	
21	0.89	2.02	3.77	7.03	10.1	13.1	18.9	24.5	29.9	35.3	40.5	45.7	45.2	38.6	33.5	29.4	23.3	19.1	16.0	13.6	11	
22	0.93	2.12	3.96	7.39	10.6	13.8	19.9	25.7	31.5	37.1	42.6	48.0	48.5	41.4	35.9	31.5	25.0	20.4	17.1	14.6	12	
23	0.98	2.22	4.16	7.76	11.2	14.5	20.9	27.0	33.0	39.0	44.7	50.4	51.9	44.2	38.2	33.7	26.7	21.9	18.2	15.4	13	

BS/DIN Standard RS Roller Chain

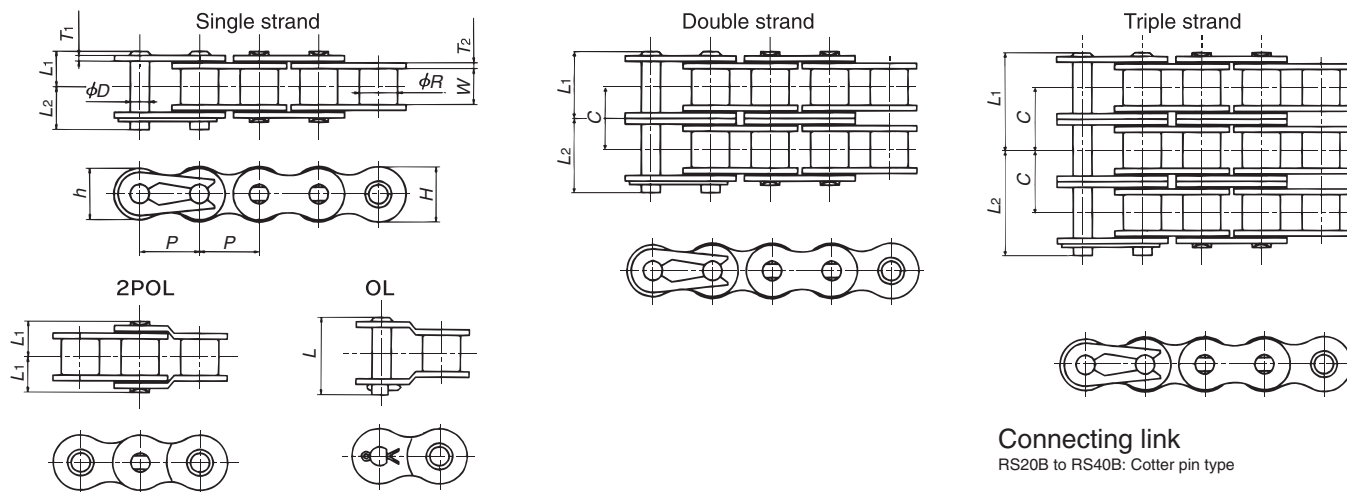

Connecting link
RS20B to RS40B: Cotter pin type

TSUBAKI Chain Number	JIS No.	Pitch P	Roller Diameter R	Inner Width of Inner Link W	Plates				Pin Diameter D
					Thickness T_1	Thickness T_2	Height H	Height h	
RS05B-1	05B	8.00	5.00	3.00	0.75	0.75	7.1	7.1	2.30
RF06B-1	06B	9.525	6.35	5.72	1.0	1.3	8.2	8.2	3.27
RS08B-1	08B	12.70	8.51	7.75	1.6	1.6	11.8	10.4	4.45
RS10B-1	10B	15.875	10.16	9.65	1.5	1.5	14.7	13.7	5.08
RS12B-1	12B	19.05	12.07	11.68	1.8	1.8	16.1	16.1	5.72
RS16B-1	16B	25.40	15.88	17.02	3.2	4.0	21.0	21.0	8.28
RS20B-1	20B	31.75	19.05	19.56	3.4	4.4	26.0	26.0	10.19
RS24B-1	24B	38.10	25.40	25.40	5.6	6.0	33.4	31.2	14.63
RS28B-1	28B	44.45	27.94	30.99	6.3	7.5	36.4	36.4	15.90
RS32B-1	32B	50.80	30.99	29.21	6.3	7.0	42.2	41.6	17.81
RS40B-1	40B	63.50	39.37	38.10	8.0	8.5	52.9	52.0	22.89
RS48B-1	48B	76.2	48.26	45.72	10.0	12.1	63.8	59.8	29.23
RS56B-1	56B	88.9	53.98	53.34	12.3	13.6	77.8	73.0	34.32

Note: Outer plate thickness is given for single-strand chain. Outer plate thickness will vary for multi-strand chains due to their relation to the horizontal pitch.

TSUBAKI Chain Number	Number of Strands	Pin Length $L_1 + L_2$	Dimensions L_1	Dimensions L_2	Offset Pin Length L	Transverse Pitch C	Tsubaki Minimum Tensile Strength kN{kgf}	ISO "B" Tensile Strength kN{kgf}	Maximum Allowable Load kN{kgf}	Approximate Mass kg/m
RS05B-1	1	8.5	3.8	4.7	—	—	5.0 {510}	4.4 {449}	1.26{128}	0.18
RF06B-1	1	13.8	6.1	7.7	15.1	—	9.0 {920}	8.90 {910}	1.95{199}	0.39
RF06B-2	2	24.0	11.2	12.8	25.9	10.24	17.0 {1730}	16.9 {1720}	3.32{339}	0.75
RF06B-3	3	34.3	16.4	17.9	36.1	—	24.9 {2540}	24.9 {2540}	4.88{498}	1.11
RS08B-1	1	18.4	8.4	10.0	18.6	—	19.0 {1930}	17.8 {1820}	3.80{387}	0.70
RS08B-2	2	32.2	15.3	16.9	34.5	13.92	32.0 {3260}	31.1 {3170}	6.46{659}	1.35
RS08B-3	3	46.1	22.25	23.85	48.4	—	47.5 {4840}	44.5 {4540}	9.50{969}	2.00
RS10B-1	1	20.8	9.55	11.25	20.8	—	23 {2340}	22.2 {2260}	4.52{461}	0.95
RS10B-2	2	37.4	17.85	19.55	39.4	16.59	44.5 {4540}	44.5 {4540}	7.68{783}	1.85
RS10B-3	3	54.0	26.15	27.85	56.0	—	66.8 {6810}	66.7 {6800}	11.3{1150}	2.80
RS12B-1	1	24.1	11.1	13.0	24.4	—	31 {3160}	28.9 {2950}	5.28{538}	1.25
RS12B-2	2	43.6	20.85	22.75	45.9	19.46	61 {6220}	57.8 {5890}	8.98{916}	2.50
RS12B-3	3	63.1	30.6	32.5	65.4	—	92 {9400}	86.7 {8840}	13.2{1350}	3.80
RS16B-1	1	37.7	17.75	19.95	41.1	—	70 {7100}	60 {6120}	13.1{1340}	2.70
RS16B-2	2	69.3	33.55	35.75	75.2	31.88	128 {13000}	106 {10800}	22.3{2270}	5.40
RS16B-3	3	101.2	49.5	51.7	107.1	—	192 {19600}	160 {16300}	32.8{3340}	8.00
RS20B-1	1	43.0	19.9	23.1	46.6	—	98.1{10000}	95 {9690}	18.4{1880}	3.85
RS20B-2	2	79.7	38.25	41.45	84.6	36.45	197 {20100}	170 {17300}	31.3{3190}	7.65
RS20B-3	3	116.2	56.5	59.7	121.0	—	295 {30100}	250 {25500}	46.0{4690}	11.45
RS24B-1	1	58.5	26.65	31.85	61.7	—	167 {17000}	160 {16300}	27.1{2760}	7.45
RS24B-2	2	106.8	50.8	56.0	112.8	48.36	335 {34100}	280 {28600}	46.1{4700}	14.65
RS24B-3	3	155.3	75.1	80.2	161.1	—	500 {51000}	425 {43300}	67.8{6910}	21.75
RS28B-1	1	69.9	32.45	37.45	74.4	—	200 {20400}	200 {20400}	37.5{3820}	9.45
RS28B-2	2	129.3	62.15	67.15	136.6	59.56	374 {38100}	360 {36700}	63.8{6510}	18.80
RS28B-3	3	188.9	91.95	96.95	195.9	—	560 {57100}	530 {54000}	93.8{9570}	28.20
RS32B-1	1	69.8	32.1	37.7	73.3	—	255 {26000}	250 {25500}	41.0{4180}	10.25
RS32B-2	2	128.1	61.25	66.85	134.5	58.55	485 {49500}	450 {45900}	69.7{7110}	20.10
RS32B-3	3	186.6	90.5	96.1	192.6	—	729 {74300}	670 {68300}	103 {10500}	29.90
RS40B-1	1	84.3	39.25	45.05	88.6	—	373 {38000}	355 {36200}	51.0{5200}	16.35
RS40B-2	2	156.6	75.4	81.2	163.2	72.29	716 {73000}	630 {64200}	86.7{8840}	32.00
RS40B-3	3	228.8	111.5	117.3	235.3	—	1080 {110000}	950 {96900}	128 {13100}	47.75
RS48B-1	1	108.1	49.3	58.8	117.7	—	565 {57600}	565 {57600}	77.0{7850}	25.00
RS48B-2	2	199.4	95.0	104.4	209.0	91.21	1000 {102000}	1000 {102000}	131 {13400}	50.00
RS48B-3	3	290.6	140.6	150.0	300.2	—	1520 {155000}	1500 {153000}	193 {19700}	75.00
RS56B-1	1	126.3	57.3	69.0	—	—	851 {86800}	850 {86700}	103 {10500}	33.90
RS56B-2	2	232.9	110.6	122.3	—	106.6	1700 {173000}	1600 {163000}	175 {17800}	67.18
RS56B-3	3	339.5	163.9	175.6	—	—	2250 {229000}	2240 {228000}	257 {26200}	100.40

- Note: 1. RF06B plate is flat: .
 2. Multi-strand RF06B and RS08B chains have one middle plate.
 3. Maximum allowable load when using 05B, 06B, 48B, 56B, connecting link (CL) is 80% of the above.
 4. Maximum allowable load when using one-pitch and two-pitch offset link (OL & 2POL) is 60% of the above.
 5. There is no offset link for 56B.

Kilowatt Ratings Tables (RS05B~RS08B)

■RS05B Maximum Kilowatt Ratings Table (kW Ratings for Single Strand Chain)

Lubrication Type Small Sprocket No. of Teeth	Small Sprocket Max rpm																										
	50	100	300	500	700	900	1200	1500	1800	2100	2500	3000	3500	4000	4500	5000	5500	6000	6500	7000	7500	8000	8500	9000	10000		
	A I					A II					B															C	
9	0.04	0.07	0.18	0.29	0.39	0.49	0.64	0.78	0.92	1.06	1.09	0.83	0.66	0.54	0.45	0.38	0.33	0.29	0.26	0.23	0.21	0.19	0.17	0.16	0.14		
10	0.04	0.08	0.21	0.33	0.44	0.55	0.72	0.87	1.03	1.18	1.27	0.97	0.77	0.63	0.53	0.45	0.39	0.34	0.30	0.27	0.25	0.22	0.20	0.19	0.16		
11	0.05	0.08	0.23	0.36	0.49	0.61	0.79	0.97	1.14	1.31	1.47	1.12	0.89	0.73	0.61	0.52	0.45	0.40	0.35	0.31	0.28	0.26	0.23	0.22	0.18		
12	0.05	0.09	0.25	0.40	0.54	0.67	0.87	1.07	1.26	1.44	1.67	1.27	1.01	0.83	0.69	0.59	0.51	0.45	0.40	0.36	0.32	0.29	0.27	0.25	0.21		
13	0.05	0.10	0.27	0.43	0.58	0.73	0.95	1.16	1.37	1.57	1.84	1.44	1.14	0.93	0.78	0.67	0.58	0.51	0.45	0.40	0.36	0.33	0.30	0.28	0.24		
14	0.06	0.11	0.30	0.47	0.63	0.79	1.03	1.26	1.48	1.70	1.99	1.60	1.27	1.04	0.87	0.75	0.65	0.57	0.50	0.45	0.41	0.37	0.34	0.31	0.26		
15	0.06	0.12	0.32	0.50	0.68	0.86	1.11	1.36	1.60	1.84	2.15	1.78	1.41	1.16	0.97	0.83	0.72	0.63	0.56	0.50	0.45	0.41	0.37	0.34	0.29		
16	0.07	0.13	0.34	0.54	0.73	0.92	1.19	1.45	1.71	1.97	2.30	1.96	1.56	1.27	1.07	0.91	0.79	0.69	0.61	0.55	0.50	0.45	0.41	0.38	0.32		
17	0.07	0.14	0.36	0.58	0.78	0.98	1.27	1.55	1.83	2.10	2.46	2.15	1.70	1.39	1.17	1.00	0.86	0.76	0.67	0.60	0.54	0.49	0.45	0.41	0.35		
18	0.08	0.14	0.39	0.61	0.83	1.04	1.35	1.65	1.94	2.23	2.61	2.34	1.86	1.52	1.27	1.09	0.94	0.83	0.73	0.66	0.59	0.54	0.49	0.45	0.38		
19	0.08	0.15	0.41	0.65	0.88	1.10	1.43	1.75	2.06	2.37	2.77	2.54	2.01	1.65	1.38	1.18	1.02	0.90	0.80	0.71	0.64	0.58	0.53	0.49	0.42		
20	0.09	0.16	0.43	0.69	0.93	1.17	1.51	1.85	2.18	2.50	2.93	2.74	2.17	1.78	1.49	1.27	1.10	0.97	0.86	0.77	0.69	0.63	0.57	0.53	0.45		
21	0.09	0.17	0.46	0.73	0.98	1.23	1.59	1.95	2.30	2.64	3.09	2.95	2.34	1.91	1.60	1.37	1.19	1.04	0.92	0.83	0.75	0.68	0.62	0.57	0.48		
22	0.10	0.18	0.48	0.76	1.03	1.29	1.68	2.05	2.42	2.78	3.25	3.16	2.51	2.05	1.72	1.47	1.27	1.12	0.99	0.89	0.80	0.73	0.66	0.61	0.52		
23	0.10	0.19	0.51	0.80	1.08	1.36	1.76	2.15	2.53	2.91	3.41	3.38	2.68	2.19	1.84	1.57	1.36	1.19	1.06	0.95	0.85	0.78	0.71	0.65	0.56		
24	0.11	0.20	0.53	0.84	1.13	1.42	1.84	2.25	2.65	3.05	3.57	3.60	2.86	2.34	1.96	1.67	1.45	1.27	1.13	1.01	0.91	0.83	0.76	0.69	0.59		
25	0.11	0.21	0.55	0.88	1.19	1.49	1.93	2.35	2.77	3.19	3.73	3.83	3.04	2.49	2.08	1.78	1.54	1.35	1.20	1.07	0.97	0.88	0.80	0.74	0.63		
26	0.12	0.21	0.58	0.91	1.24	1.55	2.01	2.46	2.89	3.32	3.89	4.06	3.22	2.64	2.21	1.89	1.64	1.44	1.27	1.14	1.03	0.93	0.85	0.78	0.67		
28	0.12	0.23	0.62	0.99	1.34	1.68	2.18	2.66	3.13	3.60	4.21	4.54	3.60	2.95	2.47	2.11	1.83	1.60	1.42	1.27	1.15	1.04	0.95	0.87	0.75		
30	0.13	0.25	0.67	1.07	1.44	1.81	2.34	2.87	3.38	3.88	4.54	5.03	3.99	3.27	2.74	2.34	2.03	1.78	1.58	1.41	1.27	1.16	1.06	0.97	0.83		
32	0.14	0.27	0.72	1.14	1.55	1.94	2.51	3.07	3.62	4.16	4.87	5.54	4.40	3.60	3.02	2.58	2.23	1.96	1.74	1.56	1.40	1.27	1.16	1.07	0.91		
35	0.16	0.30	0.80	1.26	1.70	2.14	2.77	3.38	3.99	4.58	5.36	6.32	5.03	4.12	3.45	2.95	2.56	2.24	1.99	1.78	1.60	1.46	1.33	1.22	1.04		
40	0.18	0.34	0.92	1.45	1.97	2.47	3.20	3.91	4.61	5.29	6.19	7.30	6.15	5.03	4.22	3.60	3.12	2.74	2.43	2.17	1.96	1.78	1.62	1.49	1.27		
45	0.21	0.39	1.04	1.65	2.24	2.80	3.63	4.44	5.23	6.00	7.00	8.30	7.34	6.01	5.03	4.30	3.72	3.27	2.90	2.59	2.34	2.12	1.94	1.78	1.52		

■RF06B Maximum Kilowatt Ratings Table (kW Ratings for Single Strand Chain)

Lubrication Type Small Sprocket No. of Teeth	Small Sprocket Max rpm																										
	50	100	300	500	700	900	1200	1500	1800	2100	2500	3000	3500	4000	4500	5000	5500	6000	6500	7000	7500	8000	8500	9000	10000		
	A I					A II					B															C	
9	0.07	0.13	0.34	0.54	0.72	0.91	1.18	1.44	1.70	1.62	1.25	0.95	0.75	0.62	0.52	0.44	0.38	0.34	0.30	0.27	0.24	0.22	0.20	0.18	0.16		
10	0.08	0.14	0.38	0.60	0.81	1.02	1.32	1.61	1.90	1.90	1.46	1.11	0.88	0.72	0.61	0.52	0.45	0.39	0.35	0.31	0.28	0.26	0.23	0.21	0.18		
11	0.08	0.16	0.42	0.66	0.90	1.13	1.46	1.79	2.11	2.19	1.69	1.28	1.02	0.83	0.70	0.60	0.52	0.45	0.40	0.36	0.33	0.30	0.27	0.25	0.21		
12	0.09	0.17	0.46	0.73	0.99	1.24	1.61	1.96	2.31	2.50	1.92	1.46	1.16	0.95	0.80	0.68	0.59	0.52	0.46	0.41	0.37	0.34	0.31	0.28	0.24		
13	0.10	0.19	0.50	0.80	1.08	1.35	1.75	2.14	2.52	2.82	2.17	1.65	1.31	1.07	0.90	0.77	0.67	0.58	0.52	0.46	0.42	0.38	0.35	0.32	0.27		
14	0.11	0.20	0.54	0.86	1.17	1.46	1.90	2.32	2.73	3.14	2.43	1.84	1.46	1.20	1.00	0.86	0.74	0.65	0.58	0.52	0.47	0.42	0.39	0.36	0.30		
15	0.12	0.22	0.59	0.93	1.26	1.58	2.04	2.50	2.94	3.38	2.69	2.05	1.62	1.33	1.11	0.95	0.82	0.72	0.64	0.57	0.52	0.47	0.43	0.39	0.34		
16	0.13	0.23	0.63	1.00	1.35	1.69	2.19	2.68	3.16	3.63	2.96	2.25	1.79	1.46	1.23	1.05	0.91	0.80	0.71	0.63	0.57	0.52	0.47	0.43	0.37		
17	0.13	0.25	0.67	1.06	1.44	1.81	2.34	2.86	3.37	3.87	3.25	2.47	1.96	1.60	1.34	1.15	0.99	0.87	0.77	0.69	0.62	0.57	0.52	0.48	0.41		
18	0.14	0.27	0.71	1.13	1.53	1.92	2.49	3.04	3.58	4.12	3.54	2.69	2.13	1.75	1.46	1.25	1.08	0.95	0.84	0.75	0.68	0.62	0.56	0.52	0.44		
19	0.15	0.28	0.76	1.20	1.62	2.04	2.64	3.22	3.80	4.36	3.83	2.92	2.31	1.89	1.59	1.36	1.18	1.03	0.91	0.82	0.74	0.67	0.61	0.56	0.48		
20	0.16	0.30	0.80	1.27	1.72	2.15	2.79	3.41	4.02	4.61	4.14	3.15	2.50	2.05	1.71	1.46	1.27	1.11	0.99	0.88	0.80	0.72	0.66	0.61	0.52		
21	0.17	0.31	0.84	1.34	1.81	2.27	2.94	3.59	4.23	4.86	4.46	3.39	2.69	2.20	1.84	1.58	1.37	1.20	1.06	0.95	0.86	0.78	0.71	0.65	0.56		
22	0.18	0.33	0.89	1.41	1.90	2.39	3.09	3.78	4.45	5.11	4.78	3.63	2.88	2.36	1.98	1.69	1.46	1.28	1.14	1.02	0.92	0.83	0.76	0.70	0.60		
23	0.19	0.35	0.93	1.47	2.00	2.50	3.24	3.96	4.67	5.36	5.11	3.88	3.08	2.52	2.11	1.81	1.56	1.37	1.22	1.09	0.98	0.89	0.81	0.75	0.64		
24	0.19	0.36	0.97	1.54	2.09	2.62	3.39	4.15	4.89	5.62	5.44	4.14	3.29	2.69	2.25	1.92	1.67	1.46	1.30	1.16	1.05	0.95	0.87	0.80	0.68		
25	0.20	0.38	1.02	1.61	2.18	2.74	3.55	4.34	5.11	5.87	5.79	4.40	3.49	2.86	2.40	2.05	1.77	1.56	1.38	1.24	1.11	1.01	0.92	0.85	0.72		
26	0.21	0.40	1.06	1.68	2.28	2.86	3.70	4.52	5.33	6.12	6.14	4.67	3.71	3.03	2.54	2.17	1.88	1.65	1.46	1.31	1.18	1.07	0.98	0.90	0.77		
28	0.23	0.43	1.15	1.82	2.47	3.09	4.01	4.90	5.78	6.63	6.86	5.22	4.14	3.39	2.84	2.43	2.10	1.84	1.64	1.46	1.32	1.20	1.09	1.00	0.86		
30	0.25	0.46	1.24	1.96	2.66	3.33	4.32	5.28	6.22	7.15	7.61	5.79	4.59	3.76	3.15	2.69	2.33	2.05	1.81	1.62	1.46	1.33	1.21	1.11	0.95		
32	0.27	0.49	1.33	2.11	2.85	3.58	4.63	5.66	6.67	7.66	8.38	6.38	5.06	4.14	3.47	2.96	2.57	2.25	2.00	1.79	1.61	1.46	1.34	1.23	1.05		
35	0.29	0.55	1.47	2.32	3.14	3.94	5.10	6.24	7.35	8.44	9.59	7.29	5.79	4.74	3.97	3.39	2.94	2.58	2.29	2.05	1.84	1.67	1.53	1.40	1.16		
40	0.34	0.63	1.69	2.68	3.63	4.55	5.89	7.20	8.49	9.75	11.4	8.91	7.07	5.79	4.85	4.14	3.59	3.15	2.79	2.50	2.25	2.05	1.87	1.71	1.46		
45	0.38	0.72	1.92	3.04	4.12	5.17	6.69	8.18	9.64	11.1	13.0	10.6	8.44	6.91	5.79	4.94	4.28	3.76	3.33	2.98	2.65	2.37	2.16	1.98	1.68		

■RS08B

Kilowatt Ratings Tables (RS56B)

■RS56B Maximum Kilowatt Ratings Table (kW Ratings for Single Strand Chain)

Lubrication Type Small Sprocket No. of Teeth	Small Sprocket Max rpm																			
	5	10	15	20	25	30	40	50	60	80	100	125	150	175	200	250	300	350	400	450
	A I			A II				B								C				
9	5.23	9.76	14.1	18.2	22.3	26.2	34.0	41.5	48.5	55.7	61.0	65.5	68.1	69.0	68.5	64.1	55.8	44.2	29.9	13.2
10	5.86	10.9	15.7	20.4	24.9	29.4	38.1	46.5	53.6	61.6	67.4	72.3	75.0	75.9	75.3	70.1	60.7	47.6	31.5	12.7
11	6.49	12.1	17.5	22.6	27.6	32.6	42.2	51.6	58.7	67.4	73.7	78.9	81.8	82.7	81.9	76.0	65.3	50.8	32.8	11.8
12	7.13	13.3	19.2	24.8	30.4	35.8	46.3	56.7	63.7	73.1	79.8	85.4	88.4	89.3	88.3	81.6	69.7	53.6	33.7	10.6
13	7.78	14.5	20.9	27.1	33.1	39.0	50.5	61.8	68.7	78.7	85.9	91.9	95.0	95.7	94.5	87.0	73.9	56.1	34.3	8.98
14	8.42	15.7	22.6	29.3	35.9	42.3	54.7	66.8	73.6	84.3	91.9	98.2	101	102	101	92.2	77.7	58.3	34.5	6.96
15	9.08	16.9	24.4	31.6	38.6	45.5	59.0	71.3	78.5	89.8	97.9	104	108	108	106	97.2	81.4	60.2	34.4	4.56
16	9.73	18.2	26.2	33.9	41.4	48.8	63.2	75.7	83.3	95.2	104	110	114	114	112	102	84.7	61.8	33.9	1.77
17	10.4	19.4	27.9	36.2	44.2	52.1	67.5	80.0	88.0	101	109	116	120	120	118	106	87.8	63.1	33.1	
18	11.1	20.6	29.7	38.5	47.0	55.4	71.8	84.3	92.8	106	115	122	126	126	123	111	90.7	64.1	32.0	
19	11.7	21.9	31.5	40.8	49.9	58.8	76.1	88.6	97.4	111	121	128	131	131	128	115	93.3	64.8	30.5	
20	12.4	23.1	33.3	43.1	52.7	62.1	80.5	92.9	102	116	126	134	137	137	133	119	95.6	65.2	28.7	
21	13.1	24.4	35.1	45.5	55.6	65.5	84.8	97.0	107	121	132	139	143	142	138	122	97.7	65.3	26.5	
22	13.7	25.6	36.9	47.8	58.4	68.8	89.2	101	111	126	137	145	148	147	143	126	100	65.1	24.0	
23	14.4	26.9	38.7	50.1	61.3	72.2	93.1	105	116	131	142	150	153	152	147	129	101	64.6	21.1	
24	15.1	28.1	40.5	52.5	64.2	75.6	96.7	109	120	136	147	155	158	157	152	132	102	63.8	17.9	
25	15.8	29.4	42.4	54.9	67.1	79.0	100	113	124	141	152	161	163	162	156	135	103	62.7	14.4	
26	16.4	30.7	44.2	57.2	70.0	82.5	104	117	129	146	157	166	168	166	160	138	104	61.3	10.5	

Note: 1. There is no offset link for 56B.

2. Please contact a Tsubaki representative prior to use of kW ratings in the colored area of the table.

Multi-strand factor	Number of chain strands	Multi-strand factor
	Double strand	1.7
	Triple strand	2.5

Lubrication method	A I	Manual lubrication or drip lubrication	Details on Pg. 193
	A II	Drip lubrication	
	B	Oil bath or slinger disc lubrication	
	C	Forced pump lubrication	

Lube-Free Roller Chains



Lambda Chain

Tsubaki is a pioneer in the industry, being the first to develop a chain that uses special oil-impregnated bushes. Since first being introduced in 1988, Lambda Chain has gained an outstanding reputation in a variety of industries and applications. It is capable of meeting a wide range of customer needs for long life in a lubrication-free environment, resulting in a reduction in overall long-term costs.

Long life without additional lubrication ... Special oil-impregnated bushes provide long service life.

Interchangeability Compatible with RS Standard Roller Chain.

Note: Single-strand chains use an RS standard sprocket, whereas double-strand chains require a special sprocket because the transverse pitch (dimension C) differs from that of RS Roller Chain.

Operating temperature range ... -10°C to 150°C

Selection Use the General Selection Method.



Basic Construction

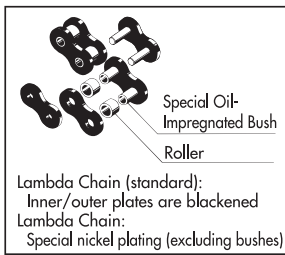

Performance in Normal Temperatures (-10°C to 60°C)

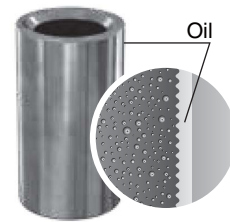
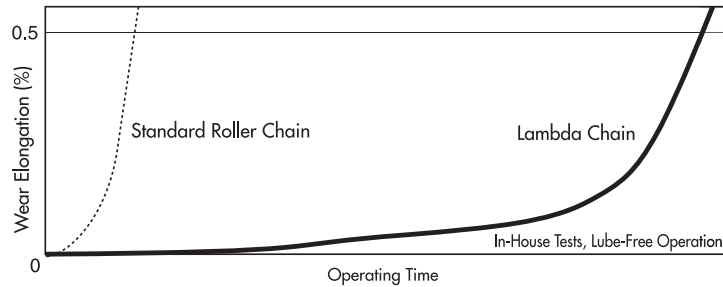

Long Life Lambda Chain (X-Λ [X-Lambda])

The inclusion of an oil-impregnated felt seal in the construction of X-Lambda Chain significantly improves the anti-wear performance of standard Lambda Chain. Ideal for environments where even longer replacement intervals compared to standard Lambda Chain are required.

Ultra long life in a lube-free chain ... The combination of a special oil-impregnated bush and felt seal further extends service life.

Interchangeability Compatible with standard Lambda Chain. However, as the overall pin length is longer than RS Roller Chain and Lambda Chain, please check that there will be no interference with machinery or other equipment.

Note: Single-strand chains use an RS standard sprocket, whereas double-strand chains require a special sprocket because the transverse pitch (dimension C) differs from that of RS Roller Chain.

Operating temperature range ... -10°C to 150°C

Selection Use the General Selection Method.



Basic Construction

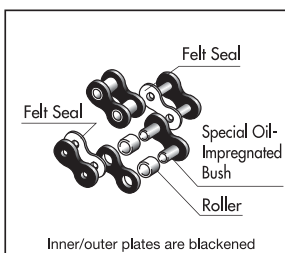

Lambda Chain KF Series (Heat Resistant Series)

Even in high-temperature environments (150°C to 230°C), our special lubricant that is resistant to volatilization and degradation brings out maximum wear performance in the chain. KF Series uses environmentally friendly NSF-H1 grade certified lube, making it usable on food processing equipment where it is difficult to lubricate and wear is a problem. KF Series has the same or better life than our Food Grade Lambda Series.

Operating temperature range ... -10°C to 230°C

Note: Best between 150°C to 230°C

Chain size RS40-LMD to RS80-LMD-KF

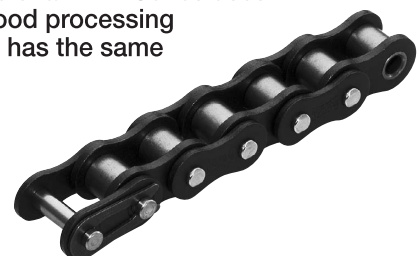

Do not use in environments over 230°C. This will lead to a serious decrease in wear life. Harmful gases may be emitted in temperatures over 280°C.

Products

■ Lambda Chain

Inner and outer plates are blackened. This treatment provides better corrosion resistance, as well as improving the overall appearance of the chain. To ensure compatibility with RS Roller Chain, the inner plate is one size thicker with the same tensile strength and maximum allowable load as RS Roller Chain. Thus, pins are longer than those of RS Roller Chain, so please check that there will be no interference with equipment.

Note: Kilowatt ratings differ slightly from RS Roller Chain.

■ BS Lambda Chain (ISO 606 B Series)

Lambda Chain that conforms to ISO 606 B Series. The dimensions are fully interchangeable with existing BS chains. Specially shaped pins are used on single-strand 08B to 16B sizes to enable easy chain disassembly using a standard chain breaker.

■ Surface-Treated Lambda Chain

Standard Lambda Chain with corrosion-resistant surface treatments on the plates and rollers.

NP: Nickel-plated plates and rollers provide mild corrosion resistance.

NEP: A special corrosion-resistant surface treatment is applied to the plates and rollers to improve corrosion resistance.

■ Heavy Duty Lambda Chain

The outer and inner plates are one size thicker than standard Lambda Chain to give the chain the same strength as RS Roller Chain, even in double-strand configuration.

Note: Requires special sprockets.

■ Curved Lambda Chain

Lambda Chain with a wide horizontal bending radius thanks to its original pin and bush construction and a large clearance between plates. Curved conveyance can be easily configured using RS standard sprockets.



Wear Life Comparison

A roller chain's wear life varies depending on the chain speed and load acting on it, the number of teeth on the sprocket, operating conditions and temperature, and so on. The graph below provides a rough guide to roller chain wear life.

*Wear life for Lambda Chain is +0.5% elongation.

Ambient temperature performance [-10°C to 60°C]

*The amount of wear life increase for RS120 and RS140 is not as large as for RS100 and below

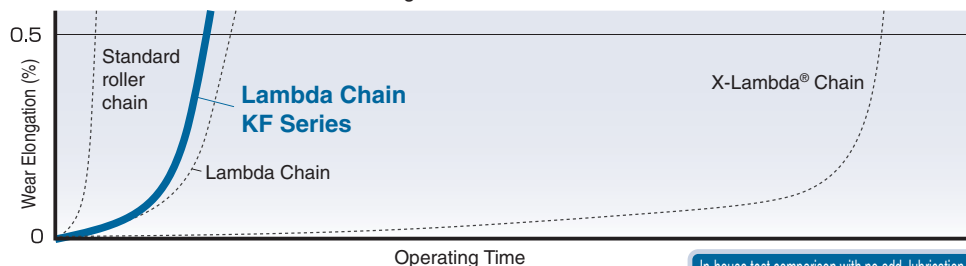

In-house test comparison with no add. lubrication

150°C Range

*The operating temperature range for Lambda and X-Lambda Chain is 150°C.

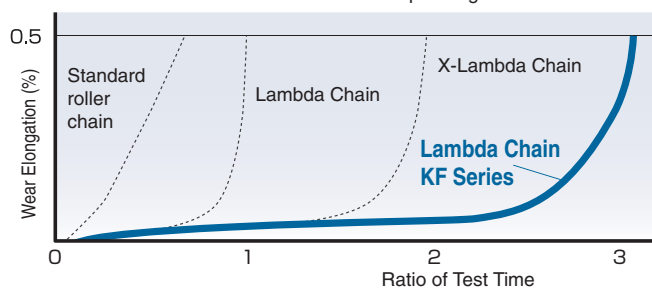

In-house test comparison with no add. lubrication

*Kilowatt ratings will drop to 3/4 of the listed catalog values when using in the 150°C - 200°C range. Select a chain to match your operating temperature.

In-house test data for RS50

In-house test comparison with no add. lubrication

230°C Range

*Data in the 230°C range provided for reference only. Do not use Lambda Chain at 230°C.

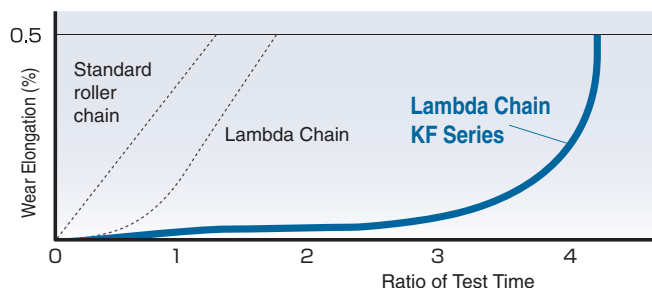

In-house test comparison with no add. lubrication

*Kilowatt ratings will drop to 1/2 of the listed catalog values when using in the 200°C - 230°C range. Select a chain to match your operating temperature.

In-house test data for RS50

In-house test comparison with no add. lubrication



Safety Precautions for Lambda Chain

- Do not use Lambda Chain if the chain will come in direct contact with food or where coating flakes or wear dust can contaminate food. Also, in non-food applications, appropriately cover the chain or contact a Tsubaki representative about chain selection if using in environments where coating flakes or wear dust present problems. Though nickel is not subject to the Japan Food Sanitation Law or the Industrial Safety and Health Law, plating on sliding parts can peel.
- Lambda Chain uses NSF-H1 non-compliant anti-rust lubrication/assembly oil.
- Do not use Lambda Chain where there is the possibility of exposure to chemicals, water, or cleaning/degreasing vapors.

■ Chain Selection: See page 163.

Lambda Chain

Single strand

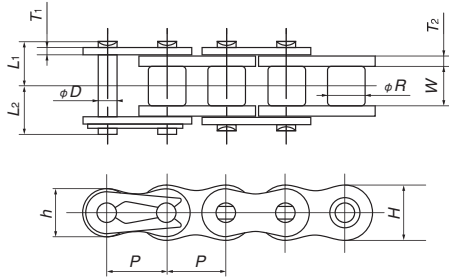

OL

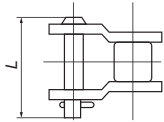

#40 - #80

OL

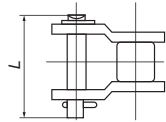

#100 - #140

Double strand

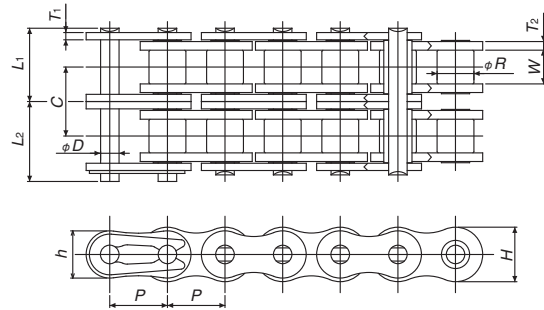

Offset links are not available for double strand.

Cotter pins are used in connecting links for RS80 and larger size chains.

Cotter pins are used in both main body and connecting links for RS100 and large chains.

TSUBAKI Chain Number		Pitch P	Roller Diameter R	Inner Width of Inner Link W	Plates				Diameter D	Pins		Offset Pin Length L
Single-strand	Double-strand				Thickness T ₁	Thickness T ₂	Height H	Height h		L ₁ 2-strand value in ()	L ₂ 2-strand value in ()	
RS40-LMD-1	RS40-LMD-2	12.70	7.92	7.55	1.5	2.0	12.0	10.4	3.97	8.75 (16.5)	10.45 (18.1)	20.0
RS50-LMD-1	RS50-LMD-2	15.875	10.16	9.26	2.0	2.4	15.0	13.0	5.09	10.75 (20.2)	12.45 (22.0)	24.0
RS60-LMD-1	RS60-LMD-2	19.05	11.91	12.28	2.4	3.2	18.1	15.6	5.96	13.70 (26.05)	15.75 (28.05)	32.0
RS80-LMD-1	RS80-LMD-2	25.40	15.88	15.48	3.2	4.0	24.1	20.8	7.94	17.15 (32.7)	20.25 (35.9)	39.9
RS100-LMD-1	RS100-LMD-2	31.75	19.05	18.70	4.0	4.8	30.1	26.0	9.54	20.65 (39.5)	23.85 (42.5)	47.5
RS120-LMD-1		38.10	22.23	24.75	4.8	5.6	36.2	31.2	11.11	25.75	29.95	59.0
RS140-LMD-1		44.45	25.40	24.75	5.6	6.4	42.2	36.4	12.71	27.70	32.20	63.7

TSUBAKI Chain Number		Minimum Tensile Strength kN{kgf} 2-strand value in ()	Approximate Mass kg/m 2-strand value in ()	Links Per Unit	Allowable Speed m/min	Transverse Pitch C
Single-strand	Double-strand					
RS40-LMD-1	RS40-LMD-2	17.7{1800} { 35.4{3600} }	0.70 (1.4)	240	150	15.4
RS50-LMD-1	RS50-LMD-2	28.4{2900} { 56.8{5800} }	1.11 (2.2)	192	135	19.0
RS60-LMD-1	RS60-LMD-2	40.2{4100} { 80.4{8200} }	1.72 (3.4)	160	120	24.52
RS80-LMD-1	RS80-LMD-2	71.6{7300} { 143{14600} }	2.77 (5.5)	120	90	31.1
RS100-LMD-1	RS100-LMD-2	107{10900} { 214{21800} }	4.30 (8.6)	96	80	37.6
RS120-LMD-1		148{15000}	6.4	80	50	
RS140-LMD-1		193{19700}	8.1	68	50	

Note 1. Maximum allowable load when using a one-pitch offset link (OL) is 65% that of the above values.

2. Offset links are not available for double-strand chains. Chains should be designed for an even number of links.

Precautions for Use

- Dust in the bush accelerates wear. Wet environments can cause the oil in the oil-impregnated bush to leak. Bushes are also coated with less rust-preventing oil, causing early rusting.
- Bush oil can leak in a vacuum, decreasing wear resistance. Do not use in a vacuum.
- The life of the chain will decrease dramatically if oil in the oil-impregnated bush is depleted. (See "(9) Lambda Chain Life" on pg. 150.)
- KW ratings for double strand Lambda Chain (Double strand coefficient)
The coefficient of a double strand chain with the same part dimensions of a single strand chain is 1.4. To achieve the same coefficient of 1.7 of a multi-strand RS Roller Chain, use a Heavy Duty Lambda Chain with thicker outer and middle plates. In any event, sprockets must be customized. Double strand RS-type sprockets cannot be used.
- Double-strand Lambda Chain pin length
Because the inner plate is thicker than that of an RS Roller Chain, the pin is longer by an equal amount (L1 and L2). Check for machine interference.

NP Series

Single strand

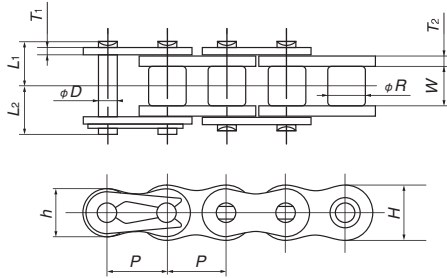

OL

OL

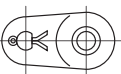
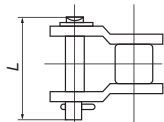
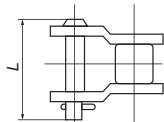

#40 - #80

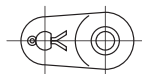

#100 - #140

Double strand

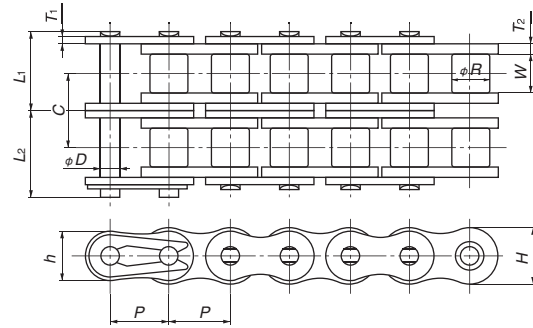

Offset links are not available for double strand.

Cotter pins are used in connecting links for RS80 and larger size chains.

Cotter pins are used in both main body and connecting links for RS100 and large chains.

TSUBAKI Chain Number		Pitch P	Roller Diameter R	Inner width of Inner Link W	Plates				Pins			Offset Pin Length L
Single-strand	Double-strand				Thickness T ₁	Thickness T ₂	Height H	Height h	Diameter D	L ₁ 2-strand value in ()	L ₂ 2-strand value in ()	
RS40-LMD-NP-1	RS40-LMD-NP-2	12.70	7.92	7.55	1.5	2.0	12.0	10.4	3.97	8.75 (16.5)	10.45 (18.1)	20.0
RS50-LMD-NP-1	RS50-LMD-NP-2	15.875	10.16	9.26	2.0	2.4	15.0	13.0	5.09	10.75 (20.2)	12.45 (22.0)	24.0
RS60-LMD-NP-1	RS60-LMD-NP-2	19.05	11.91	12.28	2.4	3.2	18.1	15.6	5.96	13.70 (26.05)	15.70 (28.05)	32.0
RS80-LMD-NP-1	RS80-LMD-NP-2	25.40	15.88	15.48	3.2	4.0	24.1	20.8	7.94	17.15 (32.7)	20.25 (35.9)	39.9
RS100-LMD-NP-1	RS100-LMD-NP-2	31.75	19.05	18.70	4.0	4.8	30.1	26.0	9.54	20.65 (39.5)	23.85 (42.5)	47.5
RS120-LMD-NP-1		38.10	22.23	24.75	4.8	5.6	36.2	31.2	11.11	25.75	29.95	59.0
RS140-LMD-NP-1		44.45	25.40	24.75	5.6	6.4	42.2	36.4	12.71	27.70	32.20	63.7

TSUBAKI Chain Number		Minimum Tensile Strength kN{kgf} 2-strand value in ()	Approximate Mass kg/m 2-strand value in ()	Links Per Unit	Allowable Speed m/min	Transverse Pitch C
Single-strand	Double-strand					
RS40-LMD-NP-1	RS40-LMD-NP-2	17.7{1800} (35.4{3600})	0.70 (1.4)	240	150	15.4
RS50-LMD-NP-1	RS50-LMD-NP-2	28.4{2900} (56.8{5800})	1.11 (2.2)	192	135	19.0
RS60-LMD-NP-1	RS60-LMD-NP-2	40.2{4100} (80.4{8200})	1.72 (3.4)	160	120	24.52
RS80-LMD-NP-1	RS80-LMD-NP-2	71.6{7300} (143{14600})	2.77 (5.5)	120	90	31.1
RS100-LMD-NP-1	RS100-LMD-NP-2	107{10900} (214{21800})	4.30 (8.6)	96	80	37.6
RS120-LMD-NP-1		148{15000}	6.4	80	50	
RS140-LMD-NP-1		193{19700}	8.1	68	50	

Note 1. Maximum allowable load when using a one-pitch offset link (OL) is 65% that of the above values.

2. Offset links are not available for double-strand chains. Chains should be designed with an even number of links.

! Nickel-plated series

Do not use nickel-plated chain if the chain will come in direct contact with food or where coating flakes or wear dust can contaminate food. Also, in non-food applications, appropriately cover the chains or contact Tsubaki about chain selection if using in environments where coating flakes and wear dust present problems. Though nickel is not subject to the Food Sanitation Law or the Industrial Safety and Health Law, plating on sliding parts can peel.

X-Lambda Chain (X- Λ)[®]

Single strand

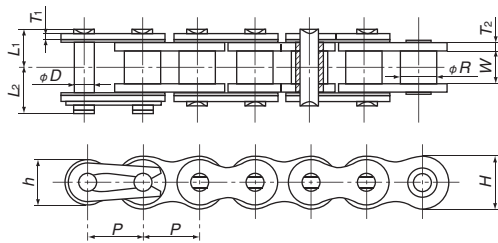

Offset links are not available with X-Lambda Chains.

Cotter pins are used in connecting links for RS80 and larger size chains.

Cotter pins are used in both main body and connecting links for RS100 and large chains.

TSUBAKI Chain Number	Pitch P	Roller Diameter R	Inner Width of Inner Link W	Plates				Pins		
				Thickness T_1	Thickness T_2	Height H	Heibht h	Diameter D	L_1	L_2
RS40-LMDX-1	12.70	7.92	7.55	1.5	2.0	12.0	10.4	3.97	9.4	11.1
RS50-LMDX-1	15.875	10.16	9.26	2.0	2.4	15.0	13.0	5.09	11.4	13.1
RS60-LMDX-1	19.05	11.91	12.28	2.4	3.2	18.1	15.6	5.96	14.8	16.5
RS80-LMDX-1	25.40	15.88	15.48	3.2	4.0	24.1	20.8	7.94	18.3	20.9
RS100-LMDX-1	31.75	19.05	18.70	4.0	4.8	30.1	26.0	9.54	21.8	24.5
RS120-LMDX-1	38.10	22.23	24.75	4.8	5.6	36.2	31.2	11.11	26.7	30.75

TSUBAKI Chain Number	Minimum Tensile Strength kN{kgf}	Approximate Mass kg/m	Number of Links Per Unit	Allowable Speed m/min
RS40-LMDX-1	17.7{1800}	0.70	240	150
RS50-LMDX-1	28.4{2900}	1.11	192	135
RS60-LMDX-1	40.2{4100}	1.72	160	120
RS80-LMDX-1	71.6{7300}	2.77	120	90
RS100-LMDX-1	107 {10900}	4.30	96	80
RS120-LMDX-1	148 {15000}	6.40	80	50

Precautions for use

- Because of its felt seals and inner plates that are thicker than RS Roller Chain's inner plates, the pins are longer (L_1 and L_2). Check for equipment interference.
- Offset links are not available for X-Lambda Chains. Chains should be designed with an even number of links.
- Due to oil in the felt seal, more oil adheres to the surface of X-Lambda Chains than regular Lambda Chains.

Connecting

Use a connecting link (with felt seal) to connect X-Lambda Chains. Set the felt seals on the inside of both the outer plate and connecting plate (Fig.1). (For chain connecting instructions, see pg. 140.)

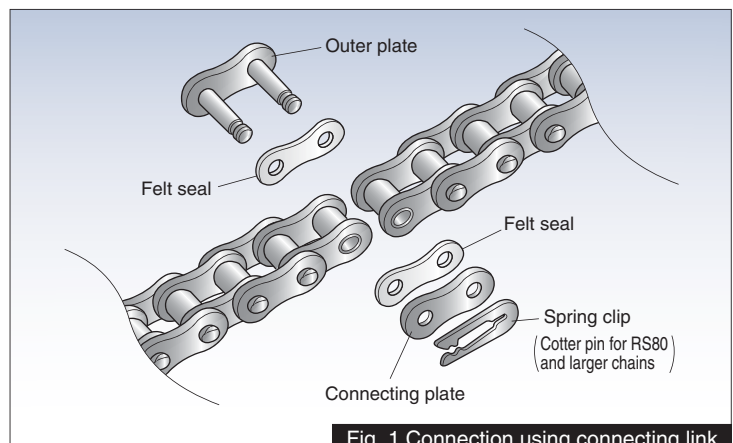
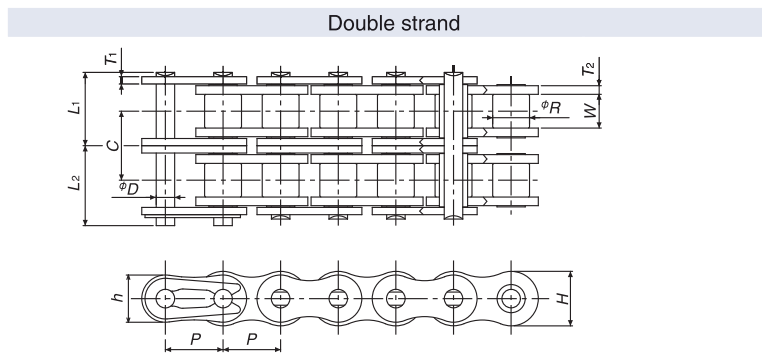
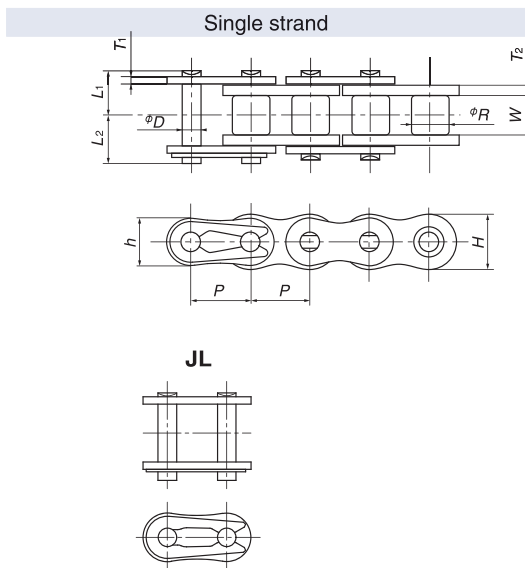

Fig. 1 Connection using connecting link

Lambda Chain KF Series (Heat Resistant Series)



Offset links are not available for double-strand Lambda Chain. Cotter pins are used in connecting links for RS80 chains.

Base Chain Dimensions

Unit: mm

Tsubaki Chain No.		Pitch <i>P</i>	Roller Dia. <i>R</i>	Width Between Inner Link Plates <i>W</i>	Plate				Dia. <i>D</i>	Pin			
Single Strand	Double Strand				Thickness <i>T</i> ₁	Thickness <i>T</i> ₂	Height <i>H</i>	Height <i>h</i>		<i>L</i> ₁		<i>L</i> ₂	
RS40-LMD-KF-1	RS40-LMD-KF-2	12.70	7.92	7.55	1.5	2.0	12.0	10.4	3.97	8.75	16.5	10.45	18.1
RS50-LMD-KF-1	RS50-LMD-KF-2	15.875	10.16	9.26	2.0	2.4	15.0	13.0	5.09	10.75	20.2	12.45	22.0
RS60-LMD-KF-1	RS60-LMD-KF-2	19.05	11.91	12.28	2.4	3.2	18.1	15.6	5.96	13.70	26.05	15.70	28.05
RS80-LMD-KF-1	RS80-LMD-KF-2	25.40	15.88	15.48	3.2	4.0	24.1	20.8	7.94	17.15	32.7	20.25	35.9

Tsubaki Chain No.		Min. Tensile Strength kN {kgf}		Approx. Mass (kg/m)		No. of Links per Unit	Allowable Speed (m/min)	Transverse Pitch <i>C</i>
Single Strand	Double Strand	Single Strand	Double Strand	Single Strand	Double Strand			
RS40-LMD-KF-1	RS40-LMD-KF-2	17.7 {1800}	35.3 {3600}	0.70	1.4	240	150	15.4
RS50-LMD-KF-1	RS50-LMD-KF-2	28.4 {2900}	56.9 {5800}	1.11	2.2	192	135	19.0
RS60-LMD-KF-1	RS60-LMD-KF-2	40.2 {4100}	80.4 {8200}	1.72	3.4	160	120	24.52
RS80-LMD-KF-1	RS80-LMD-KF-2	71.6 {7300}	143 {14600}	2.77	5.5	120	90	31.1

- Notes: 1. Offset links are not available for double-strand chain. Use an even number of links.
2. Offset links for single-strand chain use special numbering only for double-pitch offset links.

Operating Temperature Range: -10°C to 230°C

Precautions for Use

- Kilowatt ratings for double-strand Lambda Chain (multi-strand coefficient):
The multi-strand coefficient of a double-strand chain with the same part dimensions of a single-strand chain is 1.4. Special sprockets are required; double-strand RS standard sprockets cannot be used.
- Double-strand Lambda Chain pin length:
Because the inner plates are thicker than those of RS Roller Chain, the pins are longer by an equal amount (*L*₁, *L*₂). Please check that there will be no interference with equipment.
- Made to order

Chain Selection: See page 163.

Kilowatt Ratings Tables (Lambda Chain / Surface Treated Lambda Chain / X-Lambda Chain / Lambda Chain KF Series)

■RS40-LMD-1 Maximum Kilowatt Ratings Table (kW Ratings for Single Strand Chain)

Small sprocket number of teeth	Small Sprocket Max rpm											
	10	25	50	100	200	300	400	500	700	900	1000	1200
9	0.05	0.11	0.21	0.39	0.72	1.04	1.35	1.64	2.23	2.79	3.07	3.62
10	0.05	0.12	0.23	0.43	0.81	1.16	1.51	1.84	2.49	3.13	3.44	
11	0.06	0.14	0.26	0.48	0.90	1.29	1.67	2.04	2.76	3.47	3.81	
12	0.07	0.15	0.28	0.53	0.98	1.42	1.84	2.24	3.04	3.81		
13	0.07	0.17	0.31	0.57	1.07	1.54	2.00	2.45	3.31	4.15		
14	0.08	0.18	0.33	0.62	1.16	1.67	2.17	2.65	3.59			
15	0.08	0.19	0.36	0.67	1.25	1.80	2.34	2.86	3.87			
16	0.09	0.21	0.39	0.72	1.34	1.93	2.50	3.06	4.14			
17	0.10	0.22	0.41	0.77	1.43	2.06	2.67	3.27				
18	0.10	0.23	0.44	0.82	1.52	2.20	2.84	3.48				
19	0.11	0.25	0.46	0.87	1.62	2.33	3.02	3.69				
20	0.12	0.26	0.49	0.92	1.71	2.46	3.19	3.90				
21	0.12	0.28	0.52	0.96	1.80	2.59	3.36	4.11				
22	0.13	0.29	0.54	1.01	1.89	2.73	3.53	4.32				
23	0.13	0.31	0.57	1.06	1.99	2.86	3.71	4.53				
24	0.14	0.32	0.60	1.11	2.08	3.00	3.88					
25	0.15	0.33	0.62	1.16	2.17	3.13	4.06					
26	0.15	0.35	0.65	1.21	2.27	3.27	4.23					
28	0.17	0.38	0.71	1.32	2.46	3.54	4.58					
30	0.18	0.41	0.76	1.42	2.65	3.81						
32	0.19	0.44	0.81	1.52	2.84	4.09						
35	0.21	0.48	0.90	1.67	3.13	4.50						
40	0.24	0.56	1.04	1.93	3.61							
45	0.28	0.63	1.18	2.20	4.10							

■RS50-LMD-1 Maximum Kilowatt Ratings Table (kW Ratings for Single Strand Chain)

Small sprocket number of teeth	Small Sprocket Max rpm											
	10	25	50	100	200	300	400	500	600	700	800	900
9	0.10	0.23	0.43	0.80	1.49	2.15	2.78	3.40	4.01	4.60	5.19	5.77
10	0.11	0.26	0.48	0.90	1.67	2.41	3.12	3.81	4.49	5.16	5.82	
11	0.12	0.28	0.53	0.99	1.85	2.67	3.46	4.22	4.98	5.72		
12	0.14	0.31	0.58	1.09	2.03	2.93	3.80	4.64	5.47	6.28		
13	0.15	0.34	0.64	1.19	2.22	3.19	4.14	5.06	5.96			
14	0.16	0.37	0.69	1.29	2.40	3.46	4.48	5.48	6.46			
15	0.17	0.40	0.74	1.39	2.59	3.73	4.83	5.91				
16	0.19	0.43	0.80	1.49	2.78	4.00	5.18	6.33				
17	0.20	0.46	0.85	1.59	2.96	4.27	5.53	6.76				
18	0.21	0.49	0.91	1.69	3.15	4.54	5.88					
19	0.23	0.51	0.96	1.79	3.34	4.81	6.24					
20	0.24	0.54	1.01	1.89	3.53	5.09	6.59					
21	0.25	0.57	1.07	2.00	3.72	5.36	6.95					
22	0.26	0.60	1.12	2.10	3.91	5.64						
23	0.28	0.63	1.18	2.20	4.11	5.92						
24	0.29	0.66	1.24	2.30	4.30	6.19						
25	0.30	0.69	1.29	2.41	4.49	6.47						
26	0.32	0.72	1.35	2.51	4.69	6.75						
28	0.34	0.78	1.46	2.72	5.08	7.32						
30	0.37	0.84	1.57	2.93	5.47							
32	0.40	0.90	1.69	3.14	5.87							
35	0.44	0.99	1.86	3.46	6.46							
40	0.50	1.15	2.14	4.00	7.47							
45	0.57	1.30	2.44	4.54								

■RS60-LMD-1 Maximum Kilowatt Ratings Table (kW Ratings for Single Strand Chain)

Small sprocket number of teeth	Small Sprocket Max rpm											
	10	25	50	100	150	200	250	300	400	500	600	700
9	0.18	0.41	0.76	1.41	2.03	2.63	3.22	3.79	4.92	6.01	7.08	8.14
10	0.20	0.45	0.85	1.58	2.28	2.95	3.61	4.25	5.51	6.73	7.94	
11	0.22	0.50	0.94	1.75	2.53	3.27	4.00	4.71	6.11	7.46		
12	0.24	0.55	1.03	1.93	2.77	3.59	4.39	5.18	6.71	8.20		
13	0.26	0.60	1.13	2.10	3.03	3.92	4.79	5.65	7.31			
14	0.29	0.65	1.22	2.28	3.28	4.25	5.19	6.12	7.92			
15	0.31	0.70	1.31	2.45	3.53	4.57	5.59	6.59	8.54			
16	0.33	0.75	1.41	2.63	3.79	4.90	6.00	7.06				
17	0.35	0.81	1.50	2.81	4.04	5.24	6.40	7.54				
18	0.38	0.86	1.60	2.98	4.30	5.57	6.81	8.02				
19	0.40	0.91	1.70	3.16	4.56	5.90	7.22	8.51				
20	0.42	0.96	1.79	3.34	4.82	6.24	7.63	8.99				
21	0.44	1.01	1.89	3.53	5.08	6.58	8.04					
22	0.47	1.06	1.99	3.71	5.34	6.92	8.46					
23	0.49	1.12	2.08	3.89	5.60	7.26	8.87					
24	0.51	1.17	2.18	4.07	5.87	7.60	9.29					
25	0.54	1.22	2.28	4.26	6.13	7.94	9.71					
26	0.56	1.28	2.38	4.44	6.40	8.29						
28	0.61	1.38	2.58	4.81	6.93	8.98						
30	0.65	1.49	2.78	5.18	7.46	9.67						
32	0.70	1.60	2.98	5.56	8.00							
35	0.77	1.76	3.28	6.12	8.82							
40	0.89	2.03	3.79	7.07	10.2							
45	1.01	2.31	4.30	8.03								

■RS80-LMD-1 Maximum Kilowatt Ratings Table (kW Ratings for Single Strand Chain)

Small sprocket number of teeth	Small Sprocket Max rpm											
	10	25	50	75	100	125	150	200	250	300	350	
9	0.40	0.91	1.69	2.44	3.16	3.86	4.55	5.90	7.21	8.50	9.76	
10	0.45	1.02	1.90	2.73	3.54	4.33	5.10	6.61	8.08	9.52	10.9	
11	0.49	1.13	2.10	3.03	3.93	4.80	5.65	7.33	8.96	10.6		
12	0.54	1.24	2.31	3.33	4.31	5.27	6.21	8.05	9.84			
13	0.59	1.35	2.52	3.63	4.70	5.75	6.77	8.77	10.7			
14	0.64	1.46	2.73	3.93	5.09	6.23	7.34	9.51	11.6			
15	0.69	1.58	2.94	4.24	5.49	6.71	7.90	10.2				
16	0.74	1.69	3.15	4.54	5.88	7.19	8.48	11.0				
17	0.79	1.80	3.37	4.85	6.28	7.68	9.05	11.7				
18	0.84	1.92	3.58	5.16	6.68	8.17	9.63					
19	0.89	2.03	3.80	5.47	7.08	8.66	10.2					
20	0.94	2.15	4.01	5.78	7.49	9.15	10.8					
21	0.99	2.27	4.23	6.09	7.89	9.65	11.4					
22	1.04	2.38	4.45	6.41	8.30	10.1	12.0					
23	1.10	2.50	4.67	6.72	8.71	10.6	12.5					
24	1.15	2.62	4.89	7.04	9.12	11.1						
25	1.20	2.74	5.11	7.35	9.53	11.6						
26	1.25	2.85	5.33	7.67	9.94	12.2						
28	1.36	3.09	5.77	8.31	10.8	13.2						
30	1.46	3.33	6.22	8.96	11.6							
32	1.57	3.57	6.67	9.60	12.4							
35	1.73	3.94	7.34	10.6	13.7							
40	1.99	4.55	8.48	12.2								
45	2.26	5.16	9.63	13.9								

Note 1. KW ratings when using a one-pitch offset link (OL) are 80% that of the above values.
 Note 2. KW ratings shown for X-Lambda Chain, whose wear performance is 7x greater than RS Roller Chains in lube-free operation (14x for RS40 to RS60; 2.5x for RS120 and RS140) and over 5x that of Lambda Chains. (See "Glossary".)
 Note 3. Kilowatt ratings tables for RS Roller Chains differ from the above.
 Note 4. Lambda Chain KF Series must be selected with ambient temperature selection coefficients factored in. (See Pg. 163.)

Kilowatt Ratings Tables (Lambda Chain / Surface Treated Lambda Chain / X-Lambda Chain / Lambda Chain KF Series)

■RS100-LMD-1 Maximum Kilowatt Ratings Table
(kW Ratings for Single Strand Chain)

Small sprocket number of teeth	Small Sprocket Max rpm											
	10	25	50	75	100	125	150	175	200	225	250	275
9	0.66	1.51	2.82	4.07	5.27	6.44	7.59	8.72	9.83	10.9	12.0	13.1
10	0.74	1.70	3.16	4.56	5.90	7.22	8.50	9.77	11.0	12.2	13.5	
11	0.82	1.88	3.51	5.05	6.54	8.00	9.42	10.8	12.2	13.6		
12	0.90	2.06	3.85	5.55	7.19	8.79	10.4	11.9	13.4			
13	0.99	2.25	4.20	6.05	7.84	9.58	11.3	13.0				
14	1.07	2.44	4.55	6.55	8.49	10.4	12.2	14.0				
15	1.15	2.63	4.90	7.06	9.15	11.2	13.2					
16	1.23	2.82	5.26	7.57	9.81	12.0	14.1					
17	1.32	3.01	5.61	8.08	10.5	12.8						
18	1.40	3.20	5.97	8.60	11.1	13.6						
19	1.49	3.39	6.33	9.11	11.8	14.4						
20	1.57	3.58	6.69	9.63	12.5	15.3						
21	1.66	3.78	7.05	10.2	13.2							
22	1.74	3.97	7.41	10.7	13.8							
23	1.83	4.17	7.78	11.2	14.5							
24	1.91	4.36	8.14	11.7	15.2							
25	2.00	4.56	8.51	12.3	15.9							
26	2.09	4.76	8.88	12.8								
28	2.26	5.15	9.62	13.9								
30	2.43	5.55	10.4	14.9								
32	2.61	5.95	11.1	16.0								
35	2.88	6.56	12.2									
40	3.32	7.58	14.1									
45	3.77	8.60	16.1									

■RS120-LMD-1 Maximum Kilowatt Ratings Table
(kW Ratings for Single Strand Chain)

Small sprocket number of teeth	Small Sprocket Max rpm											
	5	10	15	20	25	30	40	50	60	80	100	125
9	0.65	1.22	1.75	2.27	2.77	3.27	4.23	5.17	6.09	7.90	9.65	11.8
10	0.73	1.36	1.96	2.54	3.11	3.66	4.74	5.80	6.83	8.85	10.8	13.2
11	0.81	1.51	2.17	2.82	3.44	4.06	5.25	6.42	7.57	9.81	12.0	
12	0.89	1.66	2.39	3.09	3.78	4.46	5.77	7.06	8.31	10.8	13.2	
13	0.97	1.81	2.60	3.37	4.12	4.86	6.29	7.69	9.07	11.7	14.4	
14	1.05	1.96	2.82	3.65	4.47	5.26	6.82	8.33	9.82	12.7		
15	1.13	2.11	3.04	3.94	4.81	5.67	7.35	8.98	10.6	13.7		
16	1.21	2.26	3.26	4.22	5.16	6.08	7.88	9.63	11.3	14.7		
17	1.29	2.41	3.48	4.51	5.51	6.49	8.41	10.3	12.1			
18	1.38	2.57	3.70	4.79	5.86	6.90	8.94	10.9	12.9			
19	1.46	2.72	3.92	5.08	6.21	7.32	9.48	11.6	13.7			
20	1.54	2.88	4.15	5.37	6.57	7.74	10.0	12.3	14.4			
21	1.63	3.03	4.37	5.66	6.92	8.15	10.6	12.9	15.2			
22	1.71	3.19	4.60	5.95	7.28	8.58	11.1	13.6				
23	1.79	3.35	4.82	6.25	7.64	9.00	11.7	14.2				
24	1.88	3.50	5.05	6.54	7.99	9.42	12.2	14.9				
25	1.96	3.66	5.28	6.83	8.35	9.84	12.8	15.6				
26	2.05	3.82	5.50	7.13	8.72	10.3	13.3	16.3				
28	2.22	4.14	5.96	7.72	9.44	11.1	14.4					
30	2.39	4.46	6.42	8.32	10.2	12.0	15.5					
32	2.56	4.78	6.89	8.92	10.9	12.9	16.7					
35	2.82	5.27	7.59	9.83	12.0	14.2						
40	3.26	6.08	8.76	11.4	13.9	16.4						
45	3.70	6.91	9.95	12.9	15.8							

■RS140-LMD-1 Maximum Kilowatt Ratings Table
(kW Ratings for Single Strand Chain)

Small sprocket number of teeth	Small Sprocket Max rpm											
	5	10	15	20	25	30	40	50	60	80	100	125
9	1.02	1.90	2.74	3.55	4.34	5.12	6.63	8.10	9.55	12.4	15.1	18.5
10	1.14	2.13	3.07	3.98	4.87	5.73	7.43	9.08	10.7	13.9	16.9	
11	1.27	2.36	3.41	4.41	5.39	6.35	8.23	10.1	11.9	15.4	18.8	
12	1.39	2.60	3.74	4.85	5.92	6.98	9.04	11.1	13.0	16.9		
13	1.52	2.83	4.08	5.28	6.46	7.61	9.86	12.1	14.2	18.4		
14	1.64	3.07	4.42	5.72	7.00	8.25	10.7	13.1	15.4	19.9		
15	1.77	3.30	4.76	6.17	7.54	8.88	11.5	14.1	16.6			
16	1.90	3.54	5.10	6.61	8.08	9.52	12.3	15.1	17.8			
17	2.03	3.78	5.45	7.06	8.63	10.2	13.2	16.1	19.0			
18	2.16	4.02	5.80	7.51	9.18	10.8	14.0	17.1	20.2			
19	2.29	4.27	6.14	7.96	9.73	11.5	14.9	18.2				
20	2.42	4.51	6.49	8.41	10.3	12.1	15.7	19.2				
21	2.55	4.75	6.85	8.87	10.8	12.8	16.6	20.2				
22	2.68	5.00	7.20	9.33	11.4	13.4	17.4	21.3				
23	2.81	5.24	7.55	9.78	12.0	14.1	18.3					
24	2.94	5.49	7.91	10.2	12.5	14.8	19.1					
25	3.07	5.74	8.26	10.7	13.1	15.4	20.0					
26	3.21	5.99	8.62	11.2	13.7	16.1	20.8					
28	3.48	6.48	9.34	12.1	14.8	17.4	22.6					
30	3.74	6.99	10.1	13.0	15.9	18.8						
32	4.01	7.49	10.8	14.0	17.1	20.1						
35	4.42	8.25	11.9	15.4	18.8	22.2						
40	5.11	9.53	13.7	17.8	21.7							

Note 1. KW ratings when using a one-pitch offset link (OL) are 80% that of the above values.

Note 2. KW ratings shown for X-Lambda Chain, whose wear performance is 7x greater than RS Roller Chains in lube-free operation (14x for RS40 to RS60; 2.5x for RS120 and RS140) and over 5x that of Lambda Chains. (See "Glossary".)

Note 3. Kilowatt ratings tables for RS Roller Chains differ from the above.

Note 4. Lambda Chain KF Series must be selected with ambient temperature selection coefficients factored in. (See Pg. 163.)

Heavy Duty Lambda Chain

Double strand

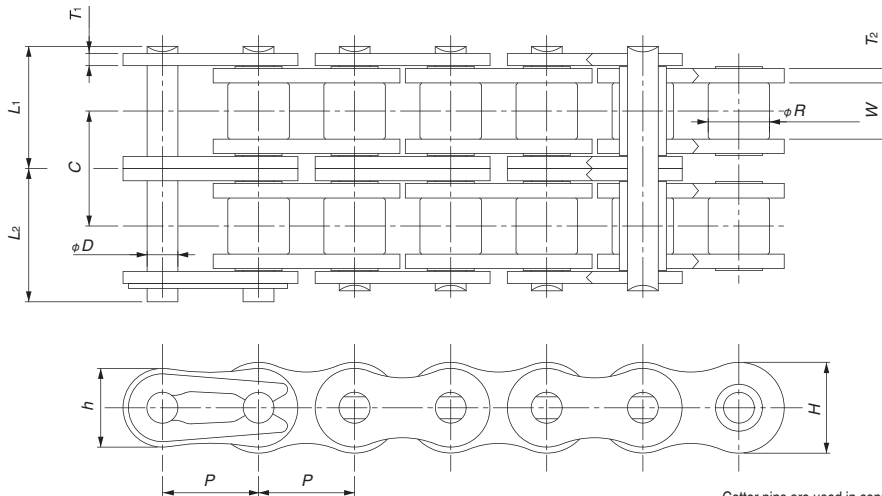

Cotter pins are used in connecting links for RS80 and larger sized chains.

TSUBAKI Chain Number Normal Specification	Pitch P	Roller Diameter R	Inner Width of Inner Link W	Plates				Pins			Transverse Pitch C
				Thickness T_1	Thickness T_2	Height H	Height h	Diameter D	L_1	L_2	
RS40-LMD-H-2	12.70	7.92	7.55	2.0	2.0	12.0	10.4	3.97	17.5	19.15	16.4
RS50-LMD-H-2	15.875	10.16	9.26	2.4	2.4	15.0	13.0	5.09	20.95	22.65	19.7
RS60-LMD-H-2	19.05	11.91	12.28	3.2	3.2	18.1	15.6	5.96	27.55	29.45	26.1
RS80-LMD-H-2	25.40	15.88	15.48	4.0	4.0	24.1	20.8	7.94	34.6	37.2	32.6
RS100-LMD-H-2	31.75	19.05	18.70	4.8	4.8	30.1	26.0	9.54	41.35	44.05	39.1

TSUBAKI Chain Number Normal Specification	Minimum Tensile Strength kN {kgf}	Approximate Mass kg/m	Number of Links Per Unit	Allowable Speed m/min
RS40-LMD-H-2	35.4 {3600}	1.57	240	150
RS50-LMD-H-2	56.8 {5800}	2.35	192	135
RS60-LMD-H-2	80.4 {8200}	3.59	160	120
RS80-LMD-H-2	143 {14600}	6.18	120	90
RS100-LMD-H-2	214 {21800}	9.03	96	80

Ambient temperature: -10 to 150°C

Sprocket

■ The chain horizontal pitch (C) differs from that of RS Roller Chain. Therefore, double-strand RS-type sprockets cannot be used. Use only customized sprockets.

Kilowatt ratings (Multiple strand coefficient)

■ The multiple-strand coefficient of Heavy Duty Lambda Chains is 1.7. To select a chain, multiply the kW ratings on pgs. 61 and 62 by 1.7.

■ Use an H-grade FCL (press fit) for the connecting link. (Using a MCL decreases the multiple strand coefficient.)

Offset link

■ Offset links are available.

Pin length

■ Because the outer and inner plates are thicker than RS Roller Chain's outer and inner plates, the pins are longer by an equal amount (L_1 and L_2). Check for machine interference.

Heavy Duty Lambda Chain NP Series

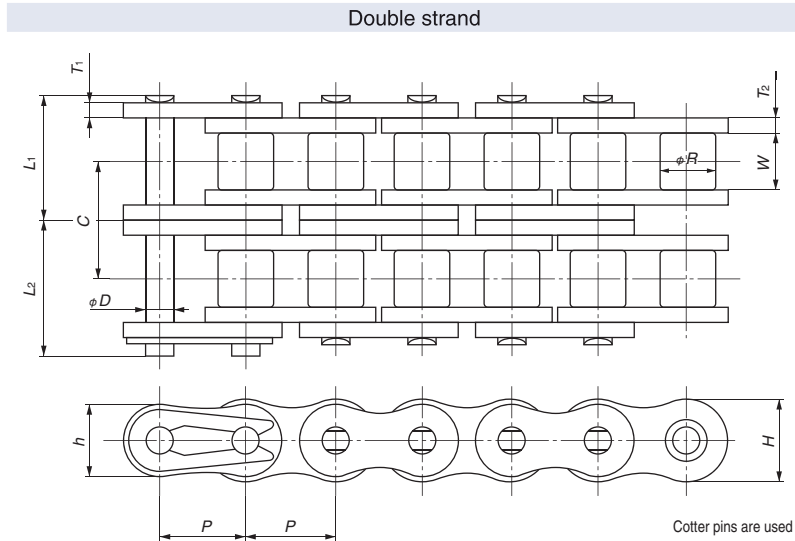

Cotter pins are used in connecting links for RS80 and larger sized chains.

TSUBAKI Chain Number Nickel-plated Specification	Pitch P	Roller Diameter R	Inner Width of Inner Link W	Plates				Pins			Transverse Pitch C
				Thickness T_1	Thickness T_2	Height H	Height h	Diameter D	L_1	L_2	
RS40-LMD-H-NP-2	12.70	7.92	7.55	2.0	2.0	12.0	10.4	3.97	17.5	19.15	16.4
RS50-LMD-H-NP-2	15.875	10.16	9.26	2.4	2.4	15.0	13.0	5.09	20.95	22.65	19.7
RS60-LMD-H-NP-2	19.05	11.91	12.28	3.2	3.2	18.1	15.6	5.96	27.55	29.45	26.1
RS80-LMD-H-NP-2	25.40	15.88	15.48	4.0	4.0	24.1	20.8	7.94	34.6	37.2	32.6
RS100-LMD-H-NP-2	31.75	19.05	18.70	4.8	4.8	30.1	26.0	9.54	41.35	44.05	39.1

TSUBAKI Chain Number Nickel-plated Specification	Minimum Tensile Strength $kN\{kgf\}$	Approximate Mass kg/m	Number of Links Per Unit	Allowable Speed m/min
RS50-LMD-H-NP-2	56.8 {5800}	2.35	192	135
RS60-LMD-H-NP-2	80.4 {8200}	3.59	160	120
RS80-LMD-H-NP-2	143 {14600}	6.18	120	90
RS100-LMD-H-NP-2	214 {21800}	9.03	96	80

Ambient temperature: -10 to 150°C

Sprocket

■ The chain horizontal pitch (C) differs from that of RS Roller Chain. Therefore, double-strand RS-type sprockets cannot be used. Use only customized sprockets.

Kilowatt ratings (Multiple strand coefficient)

■ The multiple-strand coefficient of Heavy Duty Lambda Chains is 1.7. To select a chain, multiply the kW ratings on pgs. 61 and 62 by 1.7.

■ Use an H-grade FCL (press fit) for the connecting link. (Using a MCL decreases the multiple strand coefficient.)

Offset link

■ Offset links are available.

Pin length

■ Because the outer and inner plates are thicker than RS Roller Chain's outer and inner plates, the pins are longer by an equal amount (L_1 and L_2). Check for machine interference with equipment in use.

Curved Lambda Chain

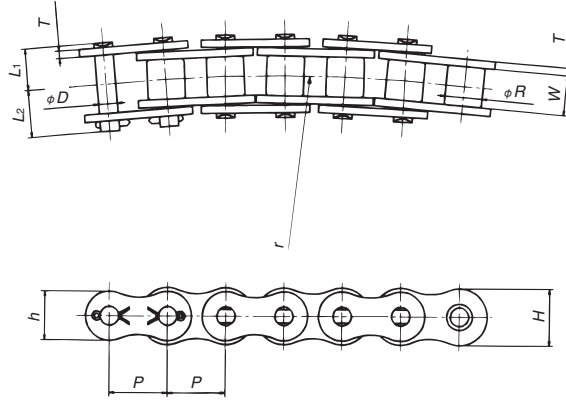

TSUBAKI Chain Number	Pitch P	Roller Diameter R	Inner Width of Inner Link W	Plates			Pins			
				Thickness T	Height H	Height h	Diameter D	$L_1 + L_2$	L_1	L_2
RS40-LMC-CU-1	12.70	7.92	7.95	1.5	12.0	10.4	3.59	18.2	8.45	9.75
RS50-LMC-CU-1	15.875	10.16	9.53	2.0	15.0	13.0	4.45	22.0	10.3	11.7
RS60-LMC-CU-1	19.05	11.91	12.70	2.4	18.1	15.6	5.35	27.5	12.95	14.55

TSUBAKI Chain Number	Minimum Tensile Strength $kN\{kgf\}$	Approximate Mass kg/m	Number of Links Per Unit	Minimum Horizontal Bending Radius r
RS40-LMC-CU-1	11.1 {1130}	0.61	240	400
RS50-LMC-CU-1	17.3 {1760}	1.01	192	500
RS60-LMC-CU-1	25.1 {2560}	1.40	160	600

Ambient temperature: -10 to 150°C

Sprocket: Can use RS Sprockets.

- Attachment chains are available.
- See 4.6 on pg. 195 for installation.

BS Lambda Chain (ISO606 B Series)

Single strand

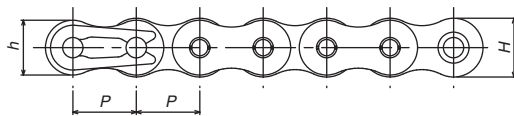
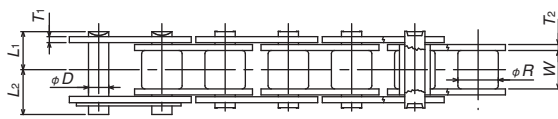

Double strand

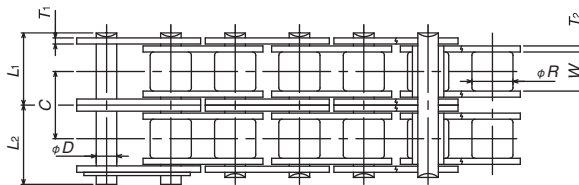

OL

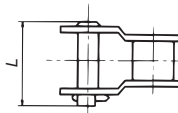

Single-pitch offset link (OL)

Cotter pins are used in connecting links for RS20B and larger sized chains.
Double-strand OL use connecting pins on both ends.

TSUBAKI Chain Number		JIS No.	Pitch P	Roller Diameter R	Inner Width of Inner Link W	Plates				Pins		
Single-strand	Double-strand					Thickness T ₁	Thickness T ₂	Height H	Height h	Diameter D	L ₁ 2-strand value in ()	L ₂ 2-strand value in ()
RF06B-LM-1	RF06B-LM-2	06B	9.525	6.35	5.72	1.0	1.3	8.2	8.2	3.28	6.1 (11.2)	7.7 (12.8)
RS08B-LM-1	RS08B-LM-2	08B	12.70	8.51	7.75	1.6	1.6	12.0	10.4	4.45	8.4 (15.3)	10.0 (16.9)
RS10B-LM-1	RS10B-LM-2	10B	15.875	10.16	9.65	1.5	1.5	14.7	13.7	5.08	9.55 (17.85)	11.25 (19.55)
RS12B-LM-1	RS12B-LM-2	12B	19.05	12.07	11.68	1.8	1.8	16.1	16.1	5.72	11.1 (20.85)	13.0 (22.75)
RS16B-LM-1	RS16B-LM-2	16B	25.40	15.88	17.02	3.2	4.0	21.0	21.0	8.28	17.75 (33.55)	19.95 (35.75)
RS20B-LM-1	RS20B-LM-2	20B	31.75	19.05	19.56	3.4	4.4	26.4	26.0	10.19	19.9 (38.25)	23.1 (41.45)
RS24B-LM-1	RS24B-LM-2	24B	38.10	25.40	25.40	5.6	6.0	33.4	31.2	14.63	26.65 (50.8)	31.85 (56.0)

TSUBAKI Chain Number		Offset Pin Length L 2-strand value in ()	Minimum Tensile Strength kN{kgf}		Approximate Mass kg/m 2-strand value in ()	Allowable Speed (m/min)	Transverse Pitch C
Single-strand	Double-strand		Single-strand	Double-strand			
RF06B-LM-1	RF06B-LM-2	15.1 (25.9)	8.90 {910}	16.9 {1720}	0.39 (0.75)	160	10.24
RS08B-LM-1	RS08B-LM-2	18.6 (34.5)	17.8 {1820}	31.1 {3170}	0.70 (1.35)	150	13.92
RS10B-LM-1	RS10B-LM-2	20.8 (39.4)	22.2 {2260}	44.5 {4540}	0.95 (1.85)	135	16.59
RS12B-LM-1	RS12B-LM-2	24.4 (45.9)	28.9 {2950}	57.8 {5890}	1.25 (2.50)	120	19.46
RS16B-LM-1	RS16B-LM-2	41.1 (75.2)	60.0 {6120}	106 {10800}	2.70 (5.40)	90	31.88
RS20B-LM-1	RS20B-LM-2	46.6 (84.6)	95.0 {9690}	170 {17300}	3.85 (7.65)	80	36.45
RS24B-LM-1	RS24B-LM-2	61.7 (112.8)	160 {16300}	280 {28600}	7.45 (14.65)	50	48.36

Note 1. RF06B plate is flat:

2. Multi-strand RF06B and RS08B chains have one middle plate.

3. Minimum tensile strength of attachment chains differs from those above. Contact a Tsubaki representative for details.

Ambient temperature: -10 to 150°C

Sprocket

■ Use BS Roller chain (ISO-compliant B Series) sprockets.

Pin type

■ Single-strand RS08B to RS16B chains use a special pin for easy cutting / connection (center sink pin).

Other sizes and double-strand chains use dual riveting.

Easy cutting / connection

■ Cutting and connecting is easy with a special tool due to a newly developed pin and new riveting style.

(On single-strand chains from RS08B to RS16B.)

Kilowatt Ratings Tables (BS Lambda Chain [ISO 606 B Series])

Before Use

Standard Roller Chains

Lube-Free Roller Chains

Heavy Duty Roller Chains

Corrosion Resistant Roller Chains

Specialty Roller Chains

Sprockets

Pin Gear Drives

Accessories

Selection

Handling

■RF06B-LM-1 Maximum Kilowatt Ratings Table (kW Ratings for Single Strand Chain)

Small sprocket number of teeth	Small Sprocket Max rpm								
	50	100	300	500	700	900	1200	1500	1800
9	0.06	0.11	0.31	0.49	0.66	0.83	1.07	1.31	1.55
10	0.07	0.13	0.35	0.55	0.74	0.93	1.20	1.47	
11	0.08	0.14	0.38	0.61	0.82	1.03	1.33	1.63	
12	0.08	0.16	0.42	0.67	0.90	1.13	1.47		
13	0.09	0.17	0.46	0.73	0.98	1.23	1.60		
14	0.10	0.18	0.50	0.79	1.07	1.34			
15	0.11	0.20	0.54	0.85	1.15	1.44			
16	0.11	0.21	0.57	0.91	1.23	1.54			
17	0.12	0.23	0.61	0.97	1.31	1.65			
18	0.13	0.24	0.65	1.03	1.40	1.75			
19	0.14	0.26	0.69	1.09	1.48				
20	0.15	0.27	0.73	1.16	1.57				
21	0.15	0.29	0.77	1.22	1.65				
22	0.16	0.30	0.81	1.28	1.74				
23	0.17	0.32	0.85	1.35	1.82				
24	0.18	0.33	0.89	1.41					
25	0.19	0.35	0.93	1.47					
26	0.19	0.36	0.97	1.54					

■RS08B-LM-1 Maximum Kilowatt Ratings Table (kW Ratings for Single Strand Chain)

Small sprocket number of teeth	Small Sprocket Max rpm											
	10	25	50	100	200	300	400	500	700	900	1000	1200
9	0.05	0.11	0.20	0.38	0.71	1.02	1.32	1.62	2.19	2.75	3.02	3.56
10	0.05	0.12	0.23	0.43	0.80	1.15	1.48	1.81	2.46	3.08	3.39	
11	0.06	0.14	0.25	0.47	0.88	1.27	1.65	2.01	2.72	3.41	3.75	
12	0.07	0.15	0.28	0.52	0.97	1.40	1.81	2.21	2.99	3.75		
13	0.07	0.16	0.30	0.57	1.06	1.52	1.97	2.41	3.26	4.09		
14	0.08	0.18	0.33	0.61	1.14	1.65	2.13	2.61	3.53			
15	0.08	0.19	0.35	0.66	1.23	1.78	2.30	2.81	3.81			
16	0.09	0.20	0.38	0.71	1.32	1.90	2.47	3.01	4.08			
17	0.10	0.22	0.41	0.76	1.41	2.03	2.63	3.22				
18	0.10	0.23	0.43	0.80	1.50	2.16	2.80	3.42				
19	0.11	0.24	0.46	0.85	1.59	2.29	2.97	3.63				
20	0.11	0.26	0.48	0.90	1.68	2.42	3.14	3.84				
21	0.12	0.27	0.51	0.95	1.77	2.55	3.31	4.04				
22	0.13	0.29	0.54	1.00	1.86	2.68	3.48	4.25				
23	0.13	0.30	0.56	1.05	1.96	2.82	3.65	4.46				
24	0.14	0.32	0.59	1.10	2.05	2.95	3.82					
25	0.14	0.33	0.61	1.15	2.14	3.08	3.99					
26	0.15	0.34	0.64	1.20	2.23	3.22	4.17					

■RS10B-LM-1 Maximum Kilowatt Ratings Table (kW Ratings for Single Strand Chain)

Small sprocket number of teeth	Small Sprocket Max rpm									
	10	25	50	100	200	300	400	500	700	900
9	0.07	0.16	0.30	0.55	1.03	1.48	1.92	2.35	3.18	3.99
10	0.08	0.18	0.33	0.62	1.15	1.66	2.15	2.63	3.56	
11	0.09	0.20	0.37	0.69	1.28	1.84	2.39	2.92	3.95	
12	0.09	0.22	0.40	0.75	1.41	2.02	2.62	3.21	4.34	
13	0.10	0.24	0.44	0.82	1.53	2.21	2.86	3.50		
14	0.11	0.26	0.48	0.89	1.66	2.39	3.10	3.79		
15	0.12	0.28	0.51	0.96	1.79	2.58	3.34	4.08		
16	0.13	0.30	0.55	1.03	1.92	2.76	3.58	4.38		
17	0.14	0.32	0.59	1.10	2.05	2.95	3.82	4.67		
18	0.15	0.34	0.63	1.17	2.18	3.14	4.06			
19	0.16	0.36	0.66	1.24	2.31	3.33	4.31			
20	0.16	0.38	0.70	1.31	2.44	3.52	4.55			
21	0.17	0.40	0.74	1.38	2.57	3.71	4.80			
22	0.18	0.42	0.78	1.45	2.71	3.90				
23	0.19	0.44	0.82	1.52	2.84	4.09				
24	0.20	0.46	0.85	1.59	2.97	4.28				
25	0.21	0.48	0.89	1.66	3.11	4.47				
26	0.22	0.50	0.93	1.74	3.24	4.67				

■RS12B-LM-1 Maximum Kilowatt Ratings Table (kW Ratings for Single Strand Chain)

Small sprocket number of teeth	Small Sprocket Max rpm										
	10	25	50	100	150	200	300	400	500	600	700
9	0.10	0.23	0.42	0.79	1.13	1.47	2.11	2.74	3.35	3.95	4.53
10	0.11	0.25	0.47	0.88	1.27	1.64	2.37	3.07	3.75	4.42	
11	0.12	0.28	0.52	0.98	1.41	1.82	2.63	3.40	4.16		
12	0.14	0.31	0.58	1.07	1.55	2.00	2.89	3.74	4.57		
13	0.15	0.34	0.63	1.17	1.69	2.18	3.15	4.08			
14	0.16	0.36	0.68	1.27	1.83	2.37	3.41	4.41			
15	0.17	0.39	0.73	1.37	1.97	2.55	3.67	4.76			
16	0.18	0.42	0.78	1.46	2.11	2.73	3.94				
17	0.20	0.45	0.84	1.56	2.25	2.92	4.20				
18	0.21	0.48	0.89	1.66	2.40	3.10	4.47				
19	0.22	0.51	0.94	1.76	2.54	3.29	4.74				
20	0.23	0.54	1.00	1.86	2.68	3.48	5.01				
21	0.25	0.56	1.05	1.96	2.83	3.67					
22	0.26	0.59	1.11	2.07	2.98	3.85					
23	0.27	0.62	1.16	2.17	3.12	4.04					
24	0.29	0.65	1.22	2.27	3.27	4.23					
25	0.30	0.68	1.27	2.37	3.42	4.43					
26	0.31	0.71	1.33	2.47	3.56	4.62					

Note 1. KW ratings when using a one-pitch offset link (OL) are 80% that of the above values.
 2. Kilowatt ratings tables for BS Roller Chains differ from the above.

Multi-strand factor	Number of chain strands	Multi-strand factor
		Double strand

Kilowatt Ratings Tables (BS Lambda Chain [ISO 606 B Series])

■RS16B-LM-1 Maximum Kilowatt Ratings Table (kW Ratings for Single Strand Chain)

Small sprocket number of teeth	Small Sprocket Max rpm							
	10	25	50	100	150	200	300	350
9	0.32	0.73	1.36	2.54	3.65	4.73	6.82	7.83
10	0.36	0.82	1.52	2.84	4.09	5.30	7.64	8.78
11	0.40	0.90	1.69	3.15	4.54	5.88	8.47	
12	0.44	0.99	1.85	3.46	4.98	6.46		
13	0.47	1.08	2.02	3.77	5.43	7.04		
14	0.51	1.17	2.19	4.09	5.89	7.63		
15	0.55	1.26	2.36	4.40	6.34	8.22		
16	0.59	1.36	2.53	4.72	6.80	8.81		
17	0.63	1.45	2.70	5.04	7.26	9.41		
18	0.68	1.54	2.87	5.36	7.72			
19	0.72	1.63	3.05	5.68	8.19			
20	0.76	1.73	3.22	6.01	8.65			
21	0.80	1.82	3.39	6.33	9.12			
22	0.84	1.91	3.57	6.66	9.59			
23	0.88	2.01	3.74	6.99	10.1			
24	0.92	2.10	3.92	7.32				
25	0.96	2.20	4.10	7.65				
26	1.00	2.29	4.27	7.98				

■RS20B-LM-1 Maximum Kilowatt Ratings Table (kW Ratings for Single Strand Chain)

Small sprocket number of teeth	Small Sprocket Max rpm						
	10	25	50	100	150	200	275
9	0.54	1.23	2.30	4.30	6.19	8.02	10.7
10	0.61	1.38	2.58	4.82	6.94	8.99	
11	0.67	1.53	2.86	5.34	7.69	9.96	
12	0.74	1.68	3.14	5.87	8.45	10.9	
13	0.81	1.84	3.43	6.39	9.21		
14	0.87	1.99	3.71	6.93	9.98		
15	0.94	2.14	4.00	7.46	10.8		
16	1.01	2.30	4.29	8.00	11.5		
17	1.08	2.45	4.58	8.54			
18	1.14	2.61	4.87	9.09			
19	1.21	2.77	5.16	9.63			
20	1.28	2.92	5.46	10.2			
21	1.35	3.08	5.75	10.7			
22	1.42	3.24	6.05	11.3			
23	1.49	3.40	6.35	11.8			
24	1.56	3.56	6.64	12.4			
25	1.63	3.72	6.94	13.0			
26	1.70	3.88	7.24				

■RS24B-LM-1 Maximum Kilowatt Ratings Table (kW Ratings for Single Strand Chain)

Small sprocket number of teeth	Small Sprocket Max rpm				
	10	25	50	100	125
9	0.97	2.20	4.11	7.67	9.38
10	1.08	2.47	4.61	8.60	10.5
11	1.20	2.74	5.11	9.53	
12	1.32	3.01	5.61	10.5	
13	1.44	3.28	6.12	11.4	
14	1.56	3.55	6.63		
15	1.68	3.83	7.14		
16	1.80	4.10	7.65		
17	1.92	4.38	8.17		
18	2.04	4.66	8.69		
19	2.17	4.94	9.22		
20	2.29	5.22	9.74		
21	2.41	5.50	10.3		
22	2.54	5.79	10.8		
23	2.66	6.07	11.3		
24	2.79	6.36	11.9		
25	2.91	6.64	12.4		
26	3.04	6.93	12.9		

Note 1. KW ratings when using a one-pitch offset link (OL) are 80% that of the above values.
 2. Kilowatt ratings tables for BS Roller Chains differ from the above.

Multi-strand factor	Number of chain strands	Multi-strand factor
	Double strand	1.4

Heavy Duty Roller Chains

1. Extensive line-up with outstanding reliability

Tsubaki's Heavy Duty Roller Chains come in a wide array of products. Their high maximum allowable load make them commonly used in compact transmission systems.

2. Uses

Use Tsubaki Heavy Duty Roller Chains when capacity exceeds that of RS Roller Chains, such as in:

1. Harsh environments where the chain will be subjected to heavy impact.
2. Compact drives for equipment or machines that must work in tight spaces.
3. When higher transmission power, allowable load or tensile strength is required.
4. When a lower rate of elastic elongation is required.

3. Tensile strength and fatigue strength comparison

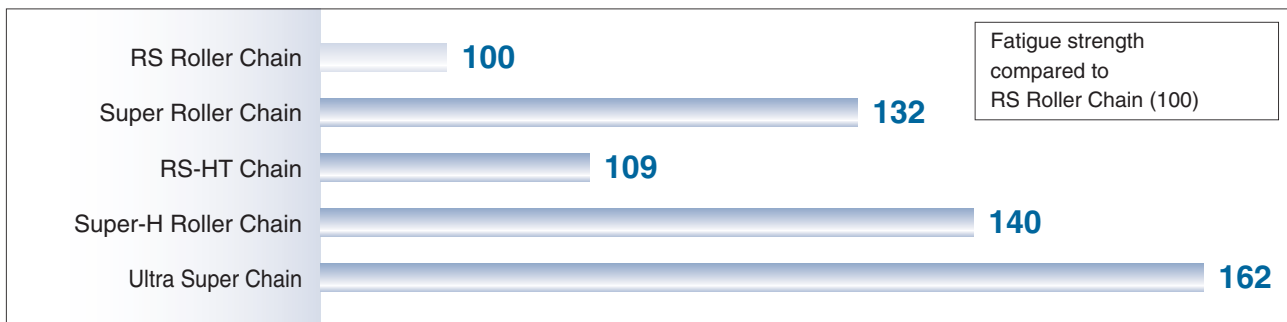
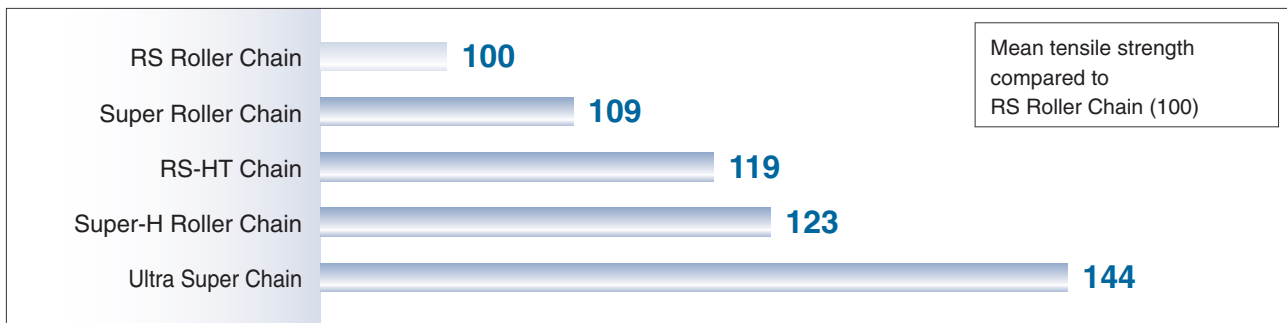

4. Applications and features

Model Item	Super Roller Chain	RS-HT Chain	Super-H Roller Chain	Ultra Super Chain
Main applications	For heavy-duty transmission, lifting			
Features	<ul style="list-style-type: none"> ● High kilowatt ratings ● High shock absorption ● Can go down one size when used in place of RS Roller Chain <p>Note Tsubaki's Heavy Duty Roller Chains are designed for low to medium speed heavy-duty transmission. RS Roller Chain should be used in speed ranges not appearing in the kilowatt ratings tables.</p>	<ul style="list-style-type: none"> ● High kilowatt ratings ● High tensile strength 	<ul style="list-style-type: none"> ● High fatigue strength ● High tensile strength ● High shock absorption 	<ul style="list-style-type: none"> ● Has the highest fatigue strength, tensile strength, and shock absorption of all Tsubaki chains. Designed for compact drives.
Example applications	Construction machinery, farm equipment, lifting mechanisms, port equipment, parking structures, etc.			
Offset links	<ul style="list-style-type: none"> ● Single-strand 4POL 	<ul style="list-style-type: none"> ● Offset links are not available. Use an even number of links. 		
Sprockets	<ul style="list-style-type: none"> ● Both single and multi-strand chains can use RS Roller Chain sprockets. 	<ul style="list-style-type: none"> ● Use sprockets made of S35C or higher carbon steel. Small sprockets must have hardened teeth. Steel sprockets cannot be used. 		
Design drawings	Pgs. 71 - 73	Pgs. 74 - 76	Pg. 77	Pg. 78

Product Line-up

Super Chain

►P71

Super Chain has the same three basic dimensions of RS Roller Chain, but it has a thicker waist that provides a 30% increase in maximum allowable load over RS Roller Chain. Suitable for situations where RS Roller Chain would suffer fatigue breakage, and allows users to go one size down.

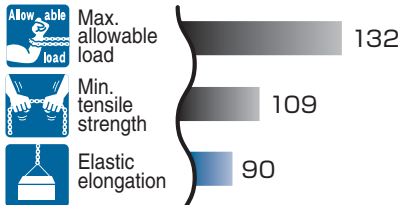

■ **Applicable sizes:**
RS80 – 240, up to sextuple strands

■ **Chain Numbering Example:**
RS80-SUP-1-M

Super Chain
Designate the connecting link type

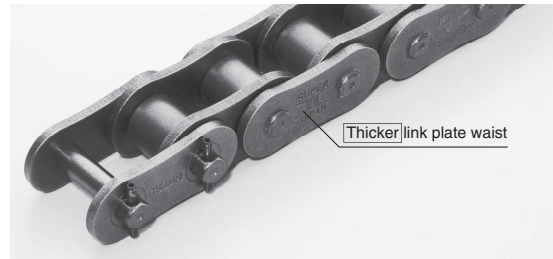

● Connecting link has same strength as the rest of the chain
Uses a connecting link that is easy to attach and remove, yet still has the same strength as the rest of the chain thanks to Tsubaki's ring coining process.



● Four pitch offset links (4POL)
Super Chain can even be used with an odd number links to create the perfect length for your needs. (4POL max. allowable load and kW ratings are 90% of the base chain. Only available for single strand chain.)

RS-HT Chain

►P74

The outer and inner plates are one size thicker than on RS Roller Chains.

RS-HT Chain has 20% greater tensile strength than RS Roller Chain, and so is ideal for applications requiring high tensile strength and low elastic elongation.

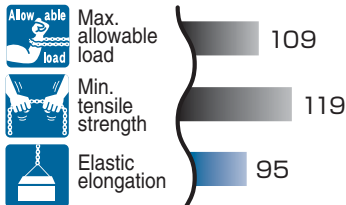

■ **Applicable Sizes:**
RS60 – RS240, up to triple strands

■ **Chain Numbering Example:**
RS80-HT-1

RS-HT Chain

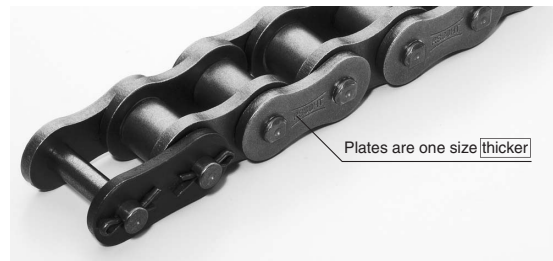

Super-H Chain

►P77

Features inner and outer link plates shaped the same way as Super Chain that are one size thicker than RS Roller Chain.

This gives Super-H Chains a higher allowable load and fatigue strength for applications requiring shock absorption.

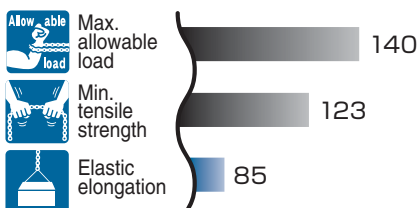

■ **Applicable Sizes:**
RS80 – RS240, up to triple strands

■ **Chain Numbering Example:**
RS80-SUP-H-1

Super-H Chain



Ultra Super Chain

►P78

Inner and outer link plates are oval and one size thicker than RS Roller Chains. Ultra Super Chains have the highest allowable load, tensile strength, and shock absorption of any Tsubaki drive chain, and are suitable for drives requiring a compact design.

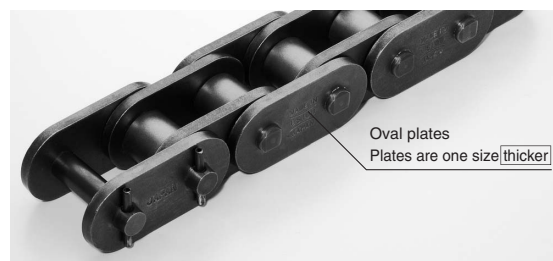
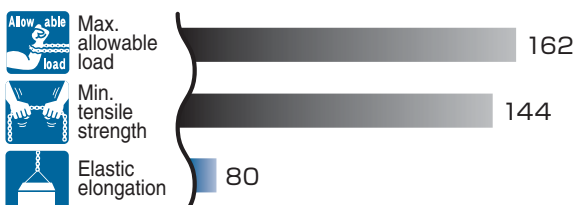

■ **Applicable Sizes:** RF100 – RF240, single strand only

■ **Chain Numbering Example:** **RF100-US-1**

*The values in each graph are shown in relation to 100 for standard roller chain. (Comparison with RS80.)

Super Roller Chain

Before Use | Standard Roller Chains | Lubrication | Heavy Duty Roller Chains | Corrosion Resistant Roller Chains | Specialty Roller Chains | Sprockets | Pin Gear Drives | Accessories | Selection | Handling

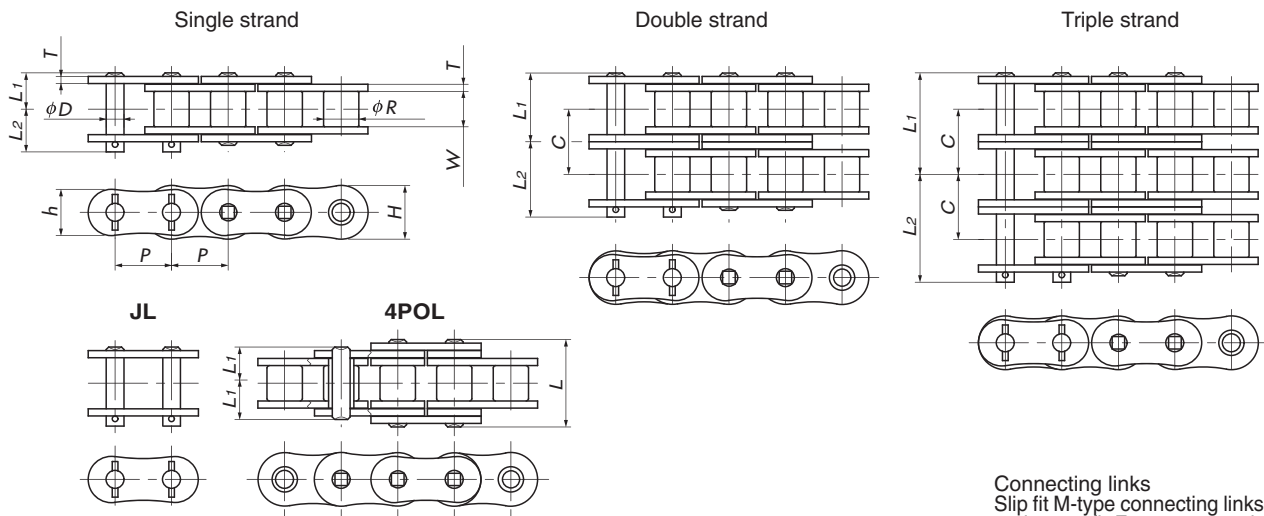

Connecting links
 Slip fit M-type connecting links (MCL)
 and press fit F-type connecting links
 (FCL) available.
 (See pg.12)

TSUBAKI Chain Number	Pitch P	Roller Diameter R	Inner Width of Inner Link W	Plates			Pins D	4 pitch offset links Pin Length L
				Thickness T	Height H	Height h		
RS80-SUP-1 RS80-SUP-2 RS80-SUP-3	25.40	15.88	15.88	3.2	24.1	20.8	7.94	39.3
RS100-SUP-1 RS100-SUP-2 RS100-SUP-3	31.75	19.05	19.05	4.0	30.1	26.0	9.54	48.0
RS120-SUP-1 RS120-SUP-2 RS120-SUP-3	38.10	22.23	25.40	4.8	36.2	31.2	11.11	59.9
RS140-SUP-1 RS140-SUP-2 RS140-SUP-3	44.45	25.40	25.40	5.6	42.2	36.4	12.71	65.7
RS160-SUP-1 RS160-SUP-2 RS160-SUP-3	50.80	28.58	31.75	6.4	48.2	41.6	14.29	77.2
RS200-SUP-1 RS200-SUP-2 RS200-SUP-3	63.50	39.68	38.10	8.0	60.3	52.0	19.85	94.9
RS240-SUP-1 RS240-SUP-2 RS240-SUP-3	76.20	47.63	47.63	9.5	72.4	62.4	23.81	116.0

TSUBAKI Chain Number	Number of Strands	Pin Length L1+L2	Dimensions L1	Dimensions L2	Transverse Pitch C	Minimum Tensile Strength kN{kgf}	Average Tensile Strength kN{kgf}	Maximum Allowable Load kN{kgf}	Approximate Mass kg/m	Links Per Unit
RS80-SUP-1 RS80-SUP-2 RS80-SUP-3	1 2 3	35.5 64.8 94.1	16.25 30.9 45.6	19.25 33.9 48.5	29.3	74.2 { 7570 } 148 { 15140 } 223 { 22710 }	85.3 { 8700 } 171 { 17400 } 256 { 26100 }	18.6 { 1900 } 31.7 { 3230 } 46.6 { 4750 }	2.81 5.62 8.40	120
RS100-SUP-1 RS100-SUP-2 RS100-SUP-3	1 2 3	42.6 78.5 114.4	19.75 37.7 55.65	22.85 40.8 58.75	35.8	111 { 11300 } 222 { 22600 } 332 { 33900 }	127 { 13000 } 255 { 26000 } 382 { 39000 }	30.4 { 3100 } 51.7 { 5270 } 76.0 { 7750 }	4.25 8.38 12.57	96
RS120-SUP-1 RS120-SUP-2 RS120-SUP-3	1 2 3	53.8 99.2 144.8	24.9 47.6 70.4	28.9 51.6 74.4	45.4	162 { 16500 } 324 { 33000 } 485 { 49500 }	186 { 19000 } 373 { 38000 } 559 { 57000 }	39.2 { 4000 } 66.7 { 6800 } 98.1 { 10000 }	6.3 12.44 18.64	80
RS140-SUP-1 RS140-SUP-2 RS140-SUP-3	1 2 3	58.6 107.5 156.6	26.9 51.35 75.85	31.7 56.15 80.75	48.9	213 { 21700 } 426 { 43400 } 638 { 65100 }	245 { 25000 } 490 { 50000 } 735 { 75000 }	53.9 { 5500 } 91.7 { 9350 } 135 { 13750 }	8.04 15.92 23.84	68
RS160-SUP-1 RS160-SUP-2 RS160-SUP-3	1 2 3	68.7 127.3 185.9	31.85 61.15 90.45	36.85 66.15 95.45	58.5	273 { 27800 } 545 { 55600 } 818 { 83400 }	314 { 32000 } 628 { 64000 } 941 { 96000 }	70.6 { 7200 } 120 { 12240 } 177 { 18000 }	10.79 21.43 32.10	60
RS200-SUP-1 RS200-SUP-2 RS200-SUP-3	1 2 3	83.8 155.5 227.2	39.0 74.85 110.75	44.8 80.65 116.45	71.6	439 { 44800 } 879 { 89600 } 1320 { 134400 }	505 { 51500 } 1010 { 103000 } 1520 { 154500 }	94.1 { 9600 } 160 { 16320 } 235 { 24000 }	17.63 34.91 52.44	48
RS240-SUP-1 RS240-SUP-2 RS240-SUP-3	1 2 3	103.4 191.3 279.0	47.9 91.9 135.85	55.5 99.4 143.15	87.8	639 { 65200 } 1280 { 130400 } 1920 { 195600 }	735 { 75000 } 1470 { 150000 } 2210 { 225000 }	132 { 13500 } 225 { 22950 } 331 { 33750 }	25.63 50.88 76.11	40

Note 1. Pins are riveted.
 2. Four-pitch offset links (4POL) available for single strand only.
 3. Maximum allowable load when using a four-pitch offset link (4POL) is 90% that of the above values.
 4. Models in bold are stock items. All other models are made-to-order.

Kilowatt Ratings Tables (RS80-SUP~RS140-SUP)

■RS80-SUP-1 Maximum Kilowatt Ratings Table (kW Ratings for Single Strand Chain)

Lubrication Type Small Sprocket No. of Teeth	Small Sprocket Max rpm											
	10	25	50	100	150	200	300	400	500	600	700	800
	A II			B			C					
13	1.00	2.28	4.25	7.93	11.4	14.8	21.3	27.6	32.1	32.1	32.1	
14	1.08	2.47	4.60	8.59	12.4	16.0	23.1	29.9	35.9	35.9	35.9	
15	1.17	2.66	4.96	9.25	13.3	17.3	24.9	32.2	39.4	39.8	39.8	
16	1.25	2.85	5.32	9.92	14.3	18.5	26.7	34.6	42.2	43.8	43.8	
17	1.33	3.04	5.68	10.6	15.3	19.8	28.5	36.9	45.1	48.0	48.0	
18	1.42	3.24	6.04	11.3	16.2	21.0	30.3	39.2	48.0	51.4	51.4	
19	1.50	3.43	6.40	11.9	17.2	22.3	32.1	41.6	50.9	54.4	54.4	
20	1.59	3.63	6.77	12.6	18.2	23.6	33.9	44.0	53.8	57.5	57.5	
21	1.68	3.82	7.13	13.3	19.2	24.8	35.8	46.3	56.7	60.7	60.7	
22	1.76	4.02	7.50	14.0	20.2	26.1	37.6	48.7	59.6	63.8	63.8	
23	1.85	4.22	7.87	14.7	21.2	27.4	39.5	51.1	62.5	66.9	66.9	
24	1.94	4.42	8.24	15.4	22.1	28.7	41.3	53.5	65.4	70.1	70.1	
25	2.02	4.61	8.61	16.1	23.1	30.0	43.2	56.0	68.4	73.2	73.2	
26	2.11	4.81	8.98	16.8	24.1	31.3	45.1	58.4	71.4	76.4	76.4	
28	2.29	5.22	9.73	18.2	26.2	33.9	48.8	63.2	77.3	83.0	83.0	83.0
30	2.46	5.62	10.5	19.6	28.2	36.5	52.6	68.1	83.3	92.1	92.1	92.1
32	2.64	6.02	11.2	21.0	30.2	39.1	56.4	73.0	89.3	101	101	101
35	2.91	6.64	12.4	23.1	33.3	43.1	62.1	80.5	98.4	116	116	116
40	3.36	7.67	14.3	26.7	38.5	49.8	71.8	93.0	114	134	137	137
45	3.82	8.71	16.2	30.3	43.7	56.6	81.5	106	129	152	156	156

■RS100-SUP-1 Maximum Kilowatt Ratings Table (kW Ratings for Single Strand Chain)

Lubrication Type Small Sprocket No. of Teeth	Small Sprocket Max rpm										
	10	25	50	100	150	200	300	400	500	600	700
	A II		B		C						
13	2.04	4.65	8.68	16.2	23.3	30.2	43.5	48.9	48.9		
14	2.21	5.04	9.40	17.6	25.3	32.8	47.2	54.0	54.0	54.0	
15	2.38	5.43	10.1	18.9	27.2	35.3	50.8	59.9	59.9	59.9	
16	2.55	5.82	10.9	20.3	29.2	37.8	54.5	66.0	66.0	66.0	
17	2.72	6.22	11.6	21.6	31.2	40.4	58.2	72.3	72.3	72.3	
18	2.90	6.61	12.3	23.0	33.2	43.0	61.9	78.8	78.8	78.8	
19	3.07	7.01	13.1	24.4	35.2	45.5	65.6	85.0	85.4	85.4	
20	3.25	7.41	13.8	25.8	37.2	48.1	69.3	89.8	91.8	91.8	
21	3.42	7.81	14.6	27.2	39.2	50.7	73.1	94.7	96.8	96.8	
22	3.60	8.21	15.3	28.6	41.2	53.4	76.9	99.6	102	102	
23	3.78	8.62	16.1	30.0	43.2	56.0	80.6	104	107	107	
24	3.95	9.02	16.8	31.4	45.2	58.6	84.4	109	112	112	
25	4.13	9.43	17.6	32.8	47.3	61.3	88.2	114	117	117	
26	4.31	9.84	18.4	34.2	49.3	63.9	92.1	119	122	122	
28	4.67	10.7	19.9	37.1	53.4	69.2	99.7	129	132	132	
30	5.03	11.5	21.4	40.0	57.6	74.6	107	139	142	142	
32	5.40	12.3	23.0	42.9	61.7	80.0	115	149	153	153	
35	5.94	13.6	25.3	47.2	68.0	88.1	127	164	170	170	170
40	6.87	15.7	29.2	54.5	78.6	102	147	190	207	207	207
45	7.80	17.8	33.2	61.9	89.2	116	166	216	247	247	247

■RS120-SUP-1 Maximum Kilowatt Ratings Table (kW Ratings for Single Strand Chain)

Lubrication Type Small Sprocket No. of Teeth	Small Sprocket Max rpm									
	10	25	50	100	150	200	300	400	500	600
	A II		B		C					
13	3.16	7.20	13.4	25.1	36.1	46.8	67.4	73.5	73.5	
14	3.42	7.80	14.6	27.2	39.1	50.7	73.0	82.2	82.2	
15	3.68	8.40	15.7	29.3	42.1	54.6	78.6	91.2	91.2	
16	3.95	9.01	16.8	31.4	45.2	58.5	84.3	100	100	
17	4.22	9.62	17.9	33.5	48.2	62.5	90.0	110	110	
18	4.48	10.2	19.1	35.6	51.3	66.5	95.8	118	118	
19	4.75	10.8	20.2	37.8	54.4	70.5	102	125	125	
20	5.03	11.5	21.4	39.9	57.5	74.5	107	132	132	
21	5.30	12.1	22.5	42.1	60.6	78.5	113	139	139	
22	5.57	12.7	23.7	44.2	63.7	82.6	119	146	146	
23	5.84	13.3	24.9	46.4	66.9	86.6	125	153	153	
24	6.12	14.0	26.0	48.6	70.0	90.7	131	160	160	
25	6.39	14.6	27.2	50.8	73.2	94.8	137	168	168	
26	6.67	15.2	28.4	53.0	76.3	98.9	142	175	175	
28	7.23	16.5	30.8	57.4	82.7	107	154	190	190	
30	7.79	17.8	33.1	61.9	89.1	115	166	204	204	
32	8.35	19.0	35.5	66.3	95.5	124	178	219	219	
35	9.20	21.0	39.1	73.1	105	136	196	247	247	247
40	10.6	24.2	45.2	84.4	122	157	227	294	302	302
45	12.1	27.5	51.4	95.8	138	179	258	334	360	360

■RS140-SUP-1 Maximum Kilowatt Ratings Table (kW Ratings for Single Strand Chain)

Lubrication Type Small Sprocket No. of Teeth	Small Sprocket Max rpm												
	10	25	50	100	150	200	250	300	350	400	450	500	550
	A II		B		C								
13	5.06	11.5	21.5	40.2	57.9	75.0	91.7	96.8	96.8	96.8			
14	5.48	12.5	23.3	43.6	62.7	81.3	99.4	109	109	109	109		
15	5.91	13.5	25.2	46.9	67.6	87.6	107	121	121	121	121		
16	6.34	14.5	27.0	50.3	72.5	93.9	115	133	133	133	133		
17	6.76	15.4	28.8	53.7	77.4	100	123	144	144	144	144		
18	7.19	16.4	30.6	57.1	82.3	107	130	153	153	153	153		
19	7.63	17.4	32.5	60.6	87.3	113	138	162	162	162	162		
20	8.06	18.4	34.3	64.0	92.2	119	146	171	171	171	171		
21	8.50	19.4	36.2	67.5	97.2	126	154	181	181	181	181		
22	8.94	20.4	38.0	71.0	102	132	162	190	190	190	190		
23	9.38	21.4	39.9	74.5	107	139	170	199	199	199	199		
24	9.82	22.4	41.8	78.0	112	146	178	209	209	209	209		
25	10.3	23.4	43.7	81.5	117	152	186	219	222	222	222	222	
26	10.7	24.4	45.6	85.0	122	159	194	229	235	235	235	235	
28	11.6	26.4	49.4	92.1	133	172	210	248	263	263	263	263	
30	12.5	28.5	53.2	99.2	143	185	226	267	292	292	292	292	
32	13.4	30.6	57.0	106	153	199	243	286	313	313	313	313	
35	14.8	33.7	62.8	117	169	219	267	315	345	345	345	345	
40	17.0	38.9	72.5	135	195	253	309	364	398	398	398	398	
45	19.4	44.1	82.4	154	221	287	351	413	464	464	464	464	

Note: 1. Use RS Roller Chains in the high speed range.
 2. Maximum allowable load when using a four-pitch offset link (OL) is 90% that of the above values.

Multi-strand factor	Number of chain strands	Multi-strand factor	Number of chain strands	Multi-strand factor
	Double strand	1.7	Quintuple strand	3.9
	Triple strand	2.5	Sextuple strand	4.6
	Quadruple strand	3.3	—	—

Lubrication method	A II	drip lubrication	Details on Pg. 193
	B	Oil bath or slinger disc lubrication	
	C	Forced pump lubrication	

Before Use
 Standard Roller Chains
 Lube-Free Roller Chains
 Heavy Duty Roller Chains
 Corrosion Resistant Roller Chains
 Specialty Roller Chains
 Sprockets
 Pin Gear Drives
 Accessories
 Selection
 Handling

Kilowatt Ratings Tables (RS160-SUP~RS240-SUP)

■RS160-SUP-1 Maximum Kilowatt Ratings Table
(kW Ratings for Single Strand Chain)

Lubrication Type Small Sprocket No. of Teeth	Small Sprocket Max rpm										
	10	25	50	100	150	200	250	300	350	400	450
	A II	B	C								
13	7.58	17.3	32.3	60.2	86.7	112	129	129	129		
14	8.21	18.7	34.9	65.2	93.9	122	145	145	145	145	
15	8.84	20.2	37.7	70.3	101	131	160	160	160	160	
16	9.48	21.6	40.4	75.3	109	141	172	177	177	177	
17	10.1	23.1	43.1	80.4	116	150	183	193	193	193	
18	10.8	24.6	45.8	85.5	123	160	195	207	207	207	
19	11.4	26.0	48.6	90.7	131	169	207	219	219	219	
20	12.1	27.5	51.4	95.9	138	179	219	232	232	232	
21	12.7	29.0	54.1	101	146	189	230	244	244	244	
22	13.4	30.5	56.9	106	153	198	242	257	257	257	
23	14.0	32.0	59.7	111	161	208	254	270	270	270	
24	14.7	33.5	62.5	117	168	218	266	282	282	282	
25	15.4	35.0	65.4	122	176	228	278	295	295	295	
26	16.0	36.5	68.2	127	183	237	290	308	308	308	
28	17.4	39.6	73.9	138	199	257	314	343	343	343	343
30	18.7	42.7	79.6	149	214	277	339	380	380	380	380
32	20.0	45.7	85.3	159	229	297	363	419	419	419	419
35	22.1	50.4	94.0	175	253	327	400	472	472	472	472
40	25.5	58.2	109	203	292	378	462	545	545	545	545
45	29.0	66.1	123	230	331	429	525	619	619	619	619

■RS200-SUP-1 Maximum Kilowatt Ratings Table
(kW Ratings for Single Strand Chain)

Lubrication Type Small Sprocket No. of Teeth	Small Sprocket Max rpm												
	10	15	20	30	40	50	70	100	150	200	250	300	350
	A II	B	C										
13	12.6	18.2	23.6	33.9	44.0	53.7	72.8	100	144	187	194	194	
14	13.7	19.7	25.5	36.8	47.6	58.2	78.8	109	156	203	211	211	211
15	14.7	21.2	27.5	39.6	51.3	62.7	84.9	117	169	218	234	234	234
16	15.8	22.8	29.5	42.5	55.0	67.3	91.0	126	181	234	258	258	258
17	16.9	24.3	31.5	45.3	58.7	71.8	97.2	134	193	250	283	283	283
18	17.9	25.8	33.5	48.2	62.5	76.4	103	143	205	266	308	308	308
19	19.0	27.4	35.5	51.1	66.2	81.0	110	151	218	282	334	334	334
20	20.1	29.0	37.5	54.0	70.0	85.6	116	160	230	298	355	355	355
21	21.2	30.5	39.5	57.0	73.8	90.2	122	168	242	314	374	374	374
22	22.3	32.1	41.6	59.9	77.6	94.9	128	177	255	330	393	393	393
23	23.4	33.7	43.6	62.8	81.4	99.5	135	186	268	347	412	412	412
24	24.5	35.3	45.7	65.8	85.2	104	141	194	280	363	432	432	432
25	25.6	36.9	47.7	68.8	89.1	109	147	203	293	379	451	451	451
26	26.7	38.4	49.8	71.7	92.9	114	154	212	305	396	471	471	471

■RS240-SUP-1 Maximum Kilowatt Ratings Table
(kW Ratings for Single Strand Chain)

Lubrication Type Small Sprocket No. of Teeth	Small Sprocket Max rpm																
	5	10	15	20	25	30	40	50	60	80	100	125	150	175	200	250	300
	A II	B	C														
13	11.4	21.3	30.6	39.7	48.5	57.1	74.0	90.5	107	138	169	206	243	276	276	276	276
14	12.3	23.0	33.2	43.0	52.5	61.9	80.2	98.0	115	150	183	224	263	303	308	308	308
15	13.3	24.8	35.7	46.3	56.6	66.7	86.4	106	124	161	197	241	284	326	341	341	341
16	14.3	26.6	38.3	49.6	60.7	71.5	92.6	113	133	173	211	258	304	350	376	376	376
17	15.2	28.4	40.9	53.0	64.8	76.3	98.9	121	142	185	226	276	325	373	412	412	412
18	16.2	30.2	43.5	56.4	68.9	81.2	105	129	151	196	240	293	346	397	448	449	449
19	17.2	32.0	46.1	59.8	73.0	86.1	112	136	161	208	254	311	366	421	475	483	483
20	18.1	33.8	48.7	63.2	77.2	91.0	118	144	170	220	269	329	387	445	502	510	510
21	19.1	35.7	51.4	66.6	81.4	95.9	124	152	179	232	283	346	408	469	529	538	538
22	20.1	37.5	54.0	70.0	85.6	101	131	160	188	244	298	364	429	493	556	565	565
23	21.1	39.4	56.7	73.4	89.8	106	137	168	197	256	313	382	450	517	583	593	593
24	22.1	41.2	59.4	76.9	94.0	111	144	175	207	268	327	400	472	542	611	621	621
25	23.1	43.1	62.0	80.4	98.2	116	150	183	216	280	342	418	493	566	638	649	649
26	24.1	44.9	64.7	83.8	102	121	156	191	225	292	357	436	514	591	666	677	677

Note: 1. Use RS Roller Chains in the high speed range.
2. Maximum allowable load when using a four-pitch offset link (OL) is 90% that of the above values.

Multi-strand factor	Number of chain strands	Multi-strand factor	Number of chain strands	Multi-strand factor
	Double strand	1.7	Quintuple strand	3.9
	Triple strand	2.5	Sextuple strand	4.6
	Quadruple strand	3.3	—	—

Lubrication method	A II	drip lubrication	Details on Pg. 193
	B	Oil bath or slinger disc lubrication	
	C	Forced pump lubrication	

RS-HT Chain

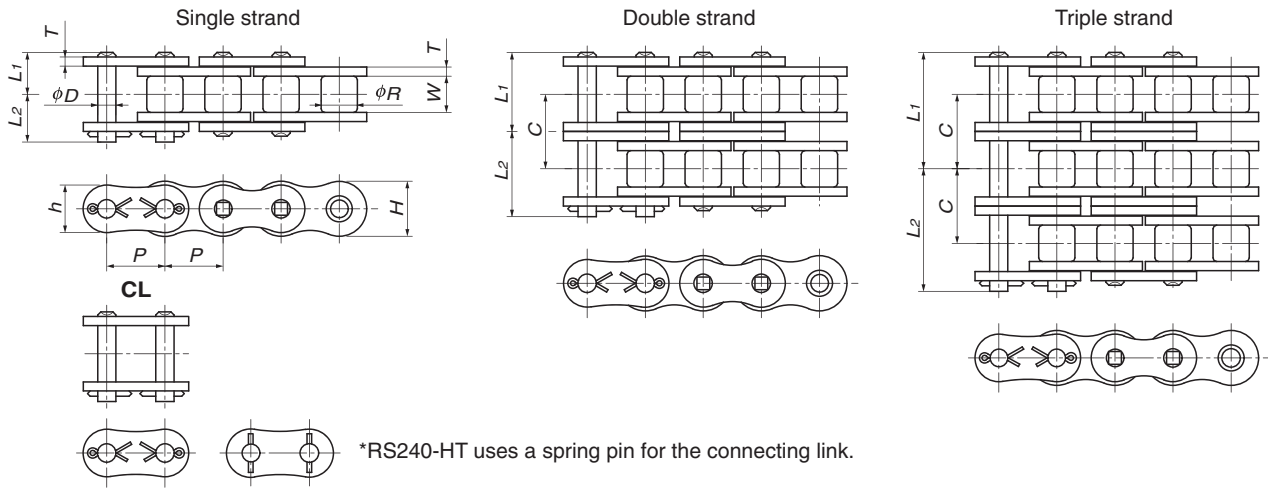

TSUBAKI Chain Number	Pitch P	Roller Diameter R	Inner Width of Inner Link W	Plates			Pins D
				Thickness T	Height H	Height h	
RS60-HT-1 RS60-HT-2 RS60-HT-3	19.05	11.91	12.70	3.2	18.1	15.6	5.96
RS80-HT-1 RS80-HT-2 RS80-HT-3	25.40	15.88	15.88	4.0	24.1	20.8	7.94
RS100-HT-1 RS100-HT-2 RS100-HT-3	31.75	19.05	19.05	4.8	30.1	26.0	9.54
RS120-HT-1 RS120-HT-2 RS120-HT-3	38.10	22.23	25.40	5.6	36.2	31.2	11.11
RS140-HT-1 RS140-HT-2 RS140-HT-3	44.45	25.40	25.40	6.4	42.2	36.4	12.71
RS160-HT-1 RS160-HT-2 RS160-HT-3	50.80	28.58	31.75	7.15	48.2	41.6	14.29
RS200-HT-1 RS200-HT-2 RS200-HT-3	63.50	39.68	38.10	9.5	60.3	52.0	19.85
RS240-HT-1 RS240-HT-2 RS240-HT-3	76.20	47.63	47.63	12.7	72.4	62.4	23.81

TSUBAKI Chain Number	Number of Strands	Dimensions L1	Dimensions L2	Transverse Pitch C	Minimum Tensile Strength kN{kgf}	Average Tensile Strength kN{kgf}	Maximum Allowable Load kN{kgf}	Approximate Mass kg/m	Links Per Unit
RS60-HT-1	1	14.8	17.0	-	48.1 { 4900 }	55.9 { 5700 }	9.81 { 1000 }	1.80	160
RS60-HT-2	2	27.8	29.9	26.1	96.1 { 9800 }	112 { 11400 }	16.7 { 1700 }	3.59	
RS60-HT-3	3	40.85	42.95	26.1	144 { 14700 }	168 { 17100 }	24.5 { 2500 }	5.36	
RS80-HT-1	1	18.3	20.9	-	81.4 { 8300 }	93.2 { 9500 }	16.2 { 1650 }	3.11	120
RS80-HT-2	2	34.6	37.2	32.6	163 { 16600 }	186 { 19000 }	27.6 { 2810 }	6.18	
RS80-HT-3	3	50.95	53.55	32.6	244 { 24900 }	279 { 28500 }	40.5 { 4130 }	9.24	
RS100-HT-1	1	21.8	24.5	-	124 { 12600 }	142 { 14500 }	24.5 { 2500 }	4.58	96
RS100-HT-2	2	41.4	44.1	39.1	247 { 25200 }	284 { 29000 }	41.7 { 4250 }	9.03	
RS100-HT-3	3	61.0	63.6	39.1	371 { 37800 }	427 { 43500 }	61.3 { 6250 }	13.54	
RS120-HT-1	1	26.95	30.55	-	167 { 17000 }	191 { 19500 }	32.4 { 3300 }	6.53	80
RS120-HT-2	2	51.4	55.0	48.9	333 { 34000 }	382 { 39000 }	55.0 { 5610 }	12.90	
RS120-HT-3	3	75.9	79.4	48.9	500 { 51000 }	574 { 58500 }	80.9 { 8250 }	19.33	
RS140-HT-1	1	28.9	33.1	-	218 { 22200 }	250 { 25500 }	42.7 { 4350 }	8.27	68
RS140-HT-2	2	55.0	59.5	52.2	435 { 44400 }	500 { 51000 }	72.6 { 7400 }	16.38	
RS140-HT-3	3	81.15	85.25	52.2	653 { 66600 }	750 { 76500 }	107 { 10880 }	24.54	
RS160-HT-1	1	33.95	38.45	-	278 { 28300 }	319 { 32500 }	55.9 { 5700 }	10.97	60
RS160-HT-2	2	64.9	69.6	61.9	555 { 56600 }	638 { 65000 }	95 { 9690 }	21.78	
RS160-HT-3	3	95.95	100.45	61.9	833 { 84900 }	956 { 97500 }	140 { 14250 }	32.63	
RS200-HT-1	1	42.9	48.1	-	486 { 49600 }	559 { 57000 }	78.5 { 8000 }	18.41	48
RS200-HT-2	2	82.05	87.3	78.3	973 { 99200 }	1120 { 114000 }	133 { 13600 }	36.47	
RS200-HT-3	3	121.25	126.55	78.3	1460 { 148800 }	1680 { 171000 }	196 { 20000 }	54.77	
RS240-HT-1	1	54.8	62.3	-	768 { 78300 }	883 { 90000 }	113 { 11500 }	29.13	40
RS240-HT-2	2	105.3	112.9	101.2	1540 { 156600 }	1770 { 180000 }	192 { 19550 }	57.35	
RS240-HT-3	3	156.05	163.55	101.2	2300 { 234900 }	2650 { 270000 }	282 { 28750 }	85.47	

Note 1. No offset links available.
2. Made-to-order product.

Before Use
 Standard Roller Chains
 Lube-Free Roller Chains
 Heavy Duty Roller Chains
 Corrosion Resistant Roller Chains
 Specialty Roller Chains
 Sprockets
 Pin Gear Drives
 Accessories
 Selection
 Handling

Kilowatt Ratings Tables (RS140HT~RS240HT)

■RS140-HT-1 Maximum Kilowatt Ratings Table (kW Ratings for Single Strand Chain)

Lubrication Type Small Sprocket No. of Teeth	Small Sprocket Max rpm										
	10	25	50	100	150	200	250	300	350	400	450
	A			B						C	
9	2.70	6.15	11.5	21.4	30.8	40.0	48.9	56.1	56.1		
10	3.02	6.89	12.9	24.0	34.6	44.8	54.7	64.5	65.6		
11	3.35	7.64	14.3	26.6	38.3	49.6	60.7	71.5	72.7		
12	3.68	8.39	15.7	29.2	42.1	54.5	66.7	78.5	79.9		
13	4.01	9.15	17.1	31.9	45.9	59.4	72.7	85.6	87.1		
14	4.34	9.91	18.5	34.5	49.7	64.4	78.7	92.8	94.4		
15	4.68	10.7	19.9	37.2	53.6	69.4	84.8	100	103		
16	5.02	11.4	21.4	39.9	57.4	74.4	90.9	107	114		
17	5.36	12.2	22.8	42.6	61.3	79.4	97.1	114	124		
18	5.70	13.0	24.3	45.3	65.2	84.5	103	122	136	136	
19	6.04	13.8	25.7	48.0	69.1	89.6	109	129	144	144	
20	6.39	14.6	27.2	50.7	73.1	94.7	116	136	152	152	
21	6.73	15.4	28.7	53.5	77.0	100	122	144	161	161	
22	7.08	16.1	30.1	56.2	81.0	105	128	151	169	169	
23	7.43	16.9	31.6	59.0	85.0	110	135	159	177	177	
24	7.78	17.7	33.1	61.8	89.0	115	141	166	186	186	
25	8.13	18.5	34.6	64.6	93.0	120	147	174	194	194	
26	8.48	19.3	36.1	67.3	97.0	126	154	181	204	204	
28	9.18	21.0	39.1	73.0	105	136	166	196	225	228	
30	9.90	22.6	42.1	78.6	113	147	179	211	243	253	
32	10.6	24.2	45.2	84.3	121	157	192	227	260	276	
35	11.7	26.7	49.8	92.8	134	173	212	250	287	304	
40	13.5	30.8	57.5	107	154	200	245	288	331	351	
45	15.3	35.0	65.3	122	175	227	278	327	376	408	408

■RS160-HT-1 Maximum Kilowatt Ratings Table (kW Ratings for Single Strand Chain)

Lubrication Type Small Sprocket No. of Teeth	Small Sprocket Max rpm									
	10	25	50	100	150	200	250	300	350	400
	A			B						C
9	4.03	9.20	17.2	32.0	46.2	59.8	73.1	74.5		
10	4.52	10.3	19.2	35.9	51.7	67.0	81.9	87.3		
11	5.01	11.4	21.3	39.8	57.3	74.3	90.8	98.5		
12	5.50	12.6	23.4	43.7	63.0	81.6	100	108		
13	6.00	13.7	25.5	47.7	68.7	88.9	109	118		
14	6.50	14.8	27.7	51.6	74.4	96.4	118	128		
15	7.00	16.0	29.8	55.6	80.1	104	127	138		
16	7.51	17.1	32.0	59.6	85.9	111	136	148		
17	8.02	18.3	34.1	63.7	91.7	119	145	162		
18	8.53	19.5	36.3	67.7	97.6	126	155	177	177	
19	9.04	20.6	38.5	71.8	103	134	164	192	192	
20	9.56	21.8	40.7	75.9	109	142	173	204	207	
21	10.1	23.0	42.9	80.0	115	149	183	215	220	
22	10.6	24.2	45.1	84.1	121	157	192	226	231	
23	11.1	25.3	47.3	88.3	127	165	201	237	243	
24	11.6	26.5	49.5	92.4	133	172	211	248	254	
25	12.2	27.7	51.8	96.6	139	180	220	260	266	
26	12.7	28.9	54.0	101	145	188	230	271	277	
28	13.7	31.3	58.5	109	157	204	249	293	300	
30	14.8	33.8	63.0	118	169	219	268	316	325	
32	15.9	36.2	67.6	126	182	235	288	339	358	
35	17.5	39.9	74.4	139	200	259	317	373	409	409
40	20.2	46.1	86.0	160	231	299	366	431	485	485
45	22.9	52.3	97.6	182	262	340	416	490	551	551

■RS200-HT-1 Maximum Kilowatt Ratings Table (kW Ratings for Single Strand Chain)

Lubrication Type Small Sprocket No. of Teeth	Small Sprocket Max rpm											
	10	15	20	30	40	50	70	100	150	200	250	300
	A			B						C		
9	7.08	10.2	13.2	19.0	24.7	30.1	40.8	56.2	81.0	105	108	
10	7.93	11.4	14.8	21.3	27.6	33.8	45.7	63.0	90.8	118	122	
11	8.79	12.7	16.4	23.6	30.6	37.4	50.7	69.9	101	130	135	
12	9.66	13.9	18.0	26.0	33.6	41.1	55.7	76.7	111	143	148	
13	10.5	15.2	19.7	28.3	36.7	44.8	60.7	83.7	121	156	161	
14	11.4	16.4	21.3	30.7	39.7	48.6	65.8	90.6	131	169	175	
15	12.3	17.7	22.9	33.0	42.8	52.3	70.8	97.6	141	182	192	
16	13.2	19.0	24.6	35.4	45.9	56.1	76.0	105	151	195	211	
17	14.1	20.3	26.3	37.8	49.0	59.9	81.1	112	161	209	231	
18	15.0	21.6	27.9	40.2	52.1	63.7	86.3	119	171	222	252	252
19	15.9	22.9	29.6	42.7	55.3	67.5	91.4	126	182	235	273	273
20	16.8	24.2	31.3	45.1	58.4	71.4	96.6	133	192	249	290	290
21	17.7	25.5	33.0	47.5	61.6	75.3	102	140	202	262	305	305
22	18.6	26.8	34.7	50.0	64.7	79.1	107	148	213	276	321	321
23	19.5	28.1	36.4	52.4	67.9	83.0	112	155	223	289	337	337
24	20.4	29.4	38.1	54.9	71.1	86.9	118	162	234	303	353	353
25	21.3	30.7	39.8	57.4	74.3	90.9	123	170	244	316	369	369
26	22.3	32.1	41.6	59.9	77.5	94.8	128	177	255	330	385	385

■RS240-HT-1 Maximum Kilowatt Ratings Table (kW Ratings for Single Strand Chain)

Lubrication Type Small Sprocket No. of Teeth	Small Sprocket Max rpm															
	5	10	15	20	25	30	40	50	60	80	100	125	150	175	200	250
	A						B									
9	6.55	12.2	17.6	22.8	27.9	32.9	42.6	52.1	61.3	79.5	97.2	119	140	159	159	
10	7.34	13.7	19.7	25.6	31.3	36.8	47.7	58.3	68.7	89.1	109	133	157	180	183	183
11	8.14	15.2	21.9	28.3	34.7	40.8	52.9	64.7	76.2	98.7	121	148	174	200	202	202
12	8.94	16.7	24.0	31.1	38.1	44.9	58.1	71.0	83.7	108	133	162	191	219	222	222
13	9.75	18.2	26.2	34.0	41.5	48.9	63.4	77.4	91.3	118	145	177	208	239	242	242
14	10.6	19.7	28.4	36.8	45.0	53.0	68.6	83.9	98.9	128	157	191	226	259	263	263
15	11.4	21.2	30.6	39.6	48.4	57.1	73.9	90.4	107	138	169	206	243	279	283	283
16	12.2	22.8	32.8	42.5	51.9	61.2	79.3	96.9	114	148	181	221	261	299	299	299
17	13.0	24.3	35.0	45.4	55.5	65.3	84.6	103	122	158	193	236	278	300	300	
18	13.9	25.9	37.2	48.3	59.0	69.5	90.0	110	130	168	205	251	296	303	303	
19	14.7	27.4	39.5	51.2	62.5	73.7	95.5	117	137	178	218	266	314	317	317	
20	15.5	29.0	41.7	54.1	66.1	77.9	101	123	145	188	230	281	330	330		
21	16.4	30.5	44.0	57.0	69.7	82.1	106	130	153	198	243	297	345	345		
22	17.2	32.1	46.3	59.9	73.3	86.3	112	137	161	209	255	312	346	346		
23	18.1	33.7	48.5	62.9	76.9	90.6	117	143	169	219	268	327	370	370		
24	18.9	35.3	50.8	65.8	80.5	94.8	123	150	177	229	280	343	396	396		
25	19.8	36.9	53.1	68.8	84.1	99.1	128	157	185	240	293	358	410	410		
26	20.6	38.5	55.4	71.8	87.7	103	134	164	193	250	306	373	418	418		

Note: 1. Use RS Roller Chains in the high speed range.

Multi-strand factor	Number of chain strands		Multi-strand factor	
	Double strand			1.7
	Triple strand			2.5

Lubrication method	A	Manual lubrication or drip lubrication	Details on Pg. 193
	B	Oil bath or slinger disc lubrication	
	C	Forced pump lubrication	

Before Use
 Standard Roller Chains
 Lubrication Type
 Heavy Duty Roller Chains
 Corrosion Resistant Roller Chains
 Specialty Roller Chains
 Sprockets
 Pin Gear Drives
 Accessories
 Selection
 Handling

Super-H Roller Chain

Single strand

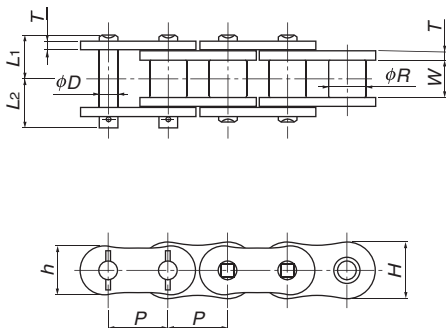

Double strand

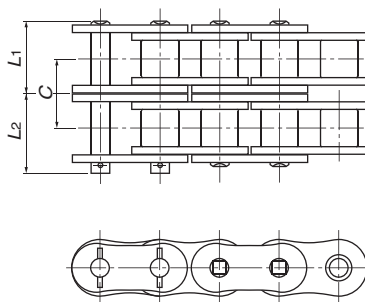

Triple strand

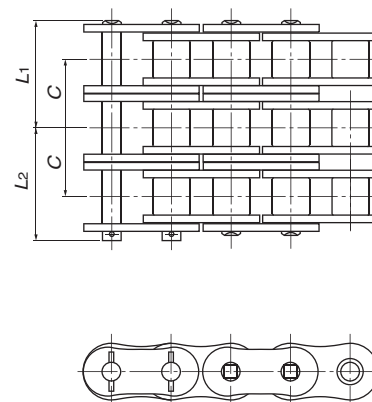

TSUBAKI Chain Number	Number of Strands	Pitch P	Roller Diameter R	Inner Width of Inner Link W	Plates			Pins			Transverse Pitch C	Minimum Tensile Strength kN{kgf}	Average Tensile Strength kN{kgf}	Maximum Allowable Load Tension kN{kgf}	Approximate Mass kg/m
					Thickness T	Width H	Width h	Diameter D	L ₁	L ₂					
RS80-SUP-H-1	1								18.3	20.9	—	85.3{ 8700}	98.1{ 10000}	20.6{ 2100}	3.29
RS80-SUP-H-2	2	25.40	15.88	15.88	4.0	24.1	20.8	7.94	34.6	37.2	32.6	171 { 17400}	196 { 20000}	35.0{ 3570}	6.52
RS80-SUP-H-3	3								50.95	53.55	32.6	256 { 26100}	294 { 30000}	51.5{ 5250}	9.75
RS100-SUP-H-1	1								21.8	24.5	—	127 { 12900}	145 { 14800}	32.4{ 3300}	4.88
RS100-SUP-H-2	2	31.75	19.05	19.05	4.8	30.1	26.0	9.54	41.4	44.1	39.1	253 { 25800}	290 { 29600}	55.0{ 5610}	9.51
RS100-SUP-H-3	3								61.0	63.6	39.1	380 { 38700}	435 { 44400}	80.9{ 8250}	14.14
RS120-SUP-H-1	1								26.95	30.55	—	171 { 17400}	196 { 20000}	42.2{ 4300}	6.94
RS120-SUP-H-2	2	38.10	22.23	25.40	5.6	36.2	31.2	11.11	51.4	55.0	48.9	341 { 34800}	392 { 40000}	71.7{ 7310}	13.51
RS120-SUP-H-3	3								75.85	79.55	48.9	512 { 52200}	588 { 60000}	105 { 10750}	20.09
RS140-SUP-H-1	1								28.9	33.1	—	222 { 22600}	255 { 26000}	56.9{ 5800}	8.88
RS140-SUP-H-2	2	44.45	25.40	25.40	6.4	42.2	36.4	12.71	55.0	59.5	52.2	443 { 45200}	510 { 52000}	96.7{ 9860}	17.38
RS140-SUP-H-3	3								81.15	85.25	52.2	665 { 67800}	765 { 78000}	142 { 14500}	25.88
RS160-SUP-H-1	1								33.95	38.45	—	281 { 28700}	324 { 33000}	73.5{ 7500}	11.72
RS160-SUP-H-2	2	50.80	28.58	31.75	7.15	48.2	41.6	14.29	64.9	69.6	61.9	563 { 57400}	647 { 66000}	125 { 12750}	22.97
RS160-SUP-H-3	3								95.95	100.45	61.9	844 { 86100}	971 { 99000}	184 { 18750}	34.22
RS200-SUP-H-1	1								42.9	48.1	—	520 { 53000}	598 { 61000}	100 { 10200}	19.68
RS200-SUP-H-2	2	63.50	39.68	38.10	9.5	60.3	52.0	19.85	82.05	87.3	78.3	1040 { 106000}	1200 { 122000}	170 { 17340}	38.48
RS200-SUP-H-3	3								121.25	126.55	78.3	1560 { 159000}	1790 { 183000}	250 { 25500}	57.29
RS240-SUP-H-1	1								54.8	62.3	—	802 { 81800}	922 { 94000}	139 { 14200}	30.47
RS240-SUP-H-2	2	76.20	47.63	47.63	12.7	72.4	62.4	23.81	105.3	112.9	101.2	1600 { 163600}	1840 { 188000}	237 { 24140}	59.77
RS240-SUP-H-3	3								156.05	163.55	101.2	2410 { 245400}	2770 { 282000}	348 { 35500}	89.09

Size	RS80 SUP-H	RS100 SUP-H	RS120 SUP-H	RS140 SUP-H	RS160 SUP-H	RS200 SUP-H	RS240 SUP-H
Number of Links Per Unit	120	96	80	68	60	48	40

Notes for use

- Select chains and sprockets as per the Allowable Load Selection Method.
- Offset links are not available due to the super heavy duty nature of transmission. Use an even number of links.
- Use drip lubrication, oil bath or splash lubrication, or forced pump lubrication.
- RS Roller Chain sprockets can be used only with single strand chains. Steel sprockets cannot be used. Use sprockets made of S35C or higher carbon steel. Sprockets with lower teeth number must also have hardened teeth. Check key strength, etc.

Ultra Super Roller Chain

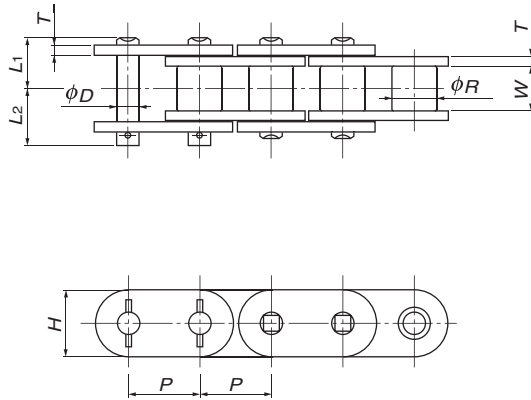

TSUBAKI Chain Number	Pitch P	Roller Diameter R	Inner Width of Inner Link W	Plates		Pins			Minimum Tensile Strength kN{kgf}	Average Tensile Strength kN{kgf}	Maximum Allowable Load Tension kN{kgf}	Approximate Mass kg/m	
				Thickness T	Width H	Diameter D	L1 + L2	L1					L2
RF100-US-1	31.75	19.05	19.05	4.8	30.1	10.32	47.7	22.35	25.35	149{15200}	172 {17500}	39.2{4000}	5.07
RF120-US-1	38.10	22.23	25.40	5.6	36.2	12.28	59.1	27.55	31.55	213{21700}	245 {25000}	53.9{5500}	7.22
RF140-US-1	44.45	25.40	25.40	6.4	42.2	13.97	63.7	29.5	34.2	273{27800}	314 {32000}	63.7{6500}	9.24
RF160-US-1	50.80	28.58	31.75	7.1	48.2	15.62	74.7	34.5	40.2	341{34800}	392 {40000}	85.3{8700}	12.19
RF200-US-1	63.50	39.68	38.10	9.5	60.3	20.41	93.9	42.95	50.95	580{59100}	667 {68000}	108{11000}	20.47
RF240-US-1	76.20	47.63	47.63	12.7	72.4	24.73	119.7	54.8	64.9	853{87000}	981{100000}	151{15400}	31.69

Notes for use

- Select chains and sprockets as per the Allowable Load Selection Method.
- Offset links are not available due to the super heavy-duty nature of transmission. Use an even number of links.
- Use drip lubrication, oil bath or splash lubrication, or forced pump lubrication.
- RS Roller Chain sprockets can be used only with single strand chains. Steel sprockets cannot be used. Use sprockets made of S35C or higher carbon steel. Sprockets with lower teeth number must also have hardened teeth. Check key strength, etc.
- Check key strength, etc.
- Multi-strand chains are not available. Consider other heavy duty chains if required.

Corrosion Resistant Roller Chains

Stainless Steel Roller Chains

These roller chains are made of stainless steel. (See pg. 189 regarding the corrosion resistance of stainless steel drive chains.)

SS Series Basic stainless steel chain using SUS304 equivalent.

These roller chains are made of 304 stainless steel (301 stainless steel clips). They offer greater corrosion resistance than RS Roller Chains and RS Surface Treated Roller Chains, and can be used in water and in corrosive atmospheres that are acidic or alkaline, as well as in low or high temperatures (-20 to 400°C). 304 stainless steel is only marginally magnetic. Some magnetism exists only due to the cold-forging process.



NS Series Highly corrosion resistant stainless steel chain using SUS316.

These roller chains are made of 316 stainless steel (301 stainless steel clips on RS25NS, and 304 stainless steel cotter pins on RS80NS). They are suited for applications that require higher corrosion resistance than SS chains. Except for the clips, they are non-magnetic.

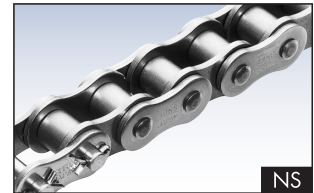

AS Series Stainless steel chain with 1.5 times the allowable load of SS Series.

The pins and rollers of these roller chains are made of precipitation-hardened, tempered stainless steel, while the plates and bushes are 18-8SUS (304 stainless steel clips are 17-7SUS (301 stainless steel)). They have a maximum allowable load that is 1.5 times that of SS chains. Corrosion resistance is slightly less than that of SS chains. AS chains are suited for applications that require corrosion resistance, heat resistance, and smaller sizes / higher kilowatt ratings than SS chains. Because of its precipitation-hardened stainless steel, the chains are magnetic.



LSC Series Lube-free, long life stainless steel chain.

This lube-free roller chain uses 18-8SUS (SUS304 equivalent) for the base chain and special engineering plastic sleeves in the bush. Suitable for situations requiring greater wear resistance than SS Series. Engineering plastic rollers also available.



Surface Treated Roller Chains

These are surface-treated RS Roller Chains.

NP Series Nickel plating provides an attractive appearance.

These chains are RS Roller Chains with nickel plating. The nickel plating not only improves appearance, but also adds a small degree of corrosion resistance. Therefore, they can be used in applications where there is exposure to water. Bear in mind when making your selection that maximum allowable load is approximately 15% lower than with RS Roller Chains.

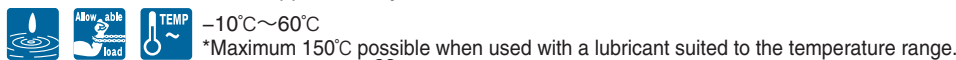

NEP Series RoHS compliant Uses a special coating for outstanding corrosion resistance.

NEP Chain is a Coating chain with a high corrosion resistance thanks to its zinc coating base and two different kinds of special surface coatings for rollers and other parts. The zinc coating and special surface coatings protect the chain body from corrosive environments, giving it superior rust prevention. NEP Chain has superior anti-rust capabilities over previous WP or DP chains, reducing its load on the environment.

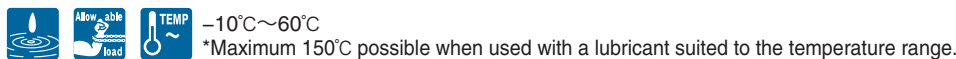

APP Series For protection against pitting corrosion fracture.

Pins are treated with a non-strength degrading surface treatment to protect against pitting corrosion that leads to fatigue breakage, making it highly effective in environments that readily promote corrosion, such as outdoor or coastal applications.

Safety precautions when using Surface Treated Drive Chains

Do not use NP / NEP Series Surface Treated Drive Chains if the chains will come in direct contact with food or where coating flakes or wear dust can contaminate food. The specific gravity of flaked NEP film is lighter than water and will float.

Also, in non-food applications, either appropriately cover the chains or contact Tsubaki about chain selection if usage is planned in environments where coating flakes and wear dust present problems. Though nickel is not subject to the Food Sanitation Law or the Industrial Safety and Health Law, plating on sliding parts can flake.

Key



Titanium Roller Chains

Titanium chains are non-magnetic and offer high corrosion resistance. For details on corrosion resistance selection, see pg. 188.



Cold Resistant Roller Chains

These chains can be used in lower temperatures than RS Roller Chains yet deliver the same allowable load (when using an F-type connecting link). Expect a 20% reduction in strength when using an M-type connecting link.

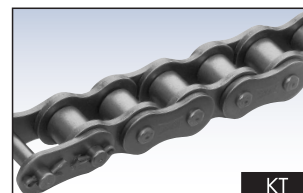

Low Noise Roller Chains

These chains emit 6 to 8 dB less noise than pre-lubed RS Roller Chains (in-house comparison testing).

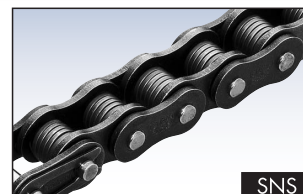

Poly Steel® Chains

■ PC (Standard Series)

Clean, quiet running chain.

The pins and outer plates of these chains are made of 304 stainless steel (301 stainless steel clips), while the inner plates are of engineered plastic (white). They are lube-free, low noise (5 dB less than RS Roller Chains) and lightweight (50% of RS Roller Chains). They can be used in temperatures of -20 to 80°C. For details on corrosion resistance selection, see pg. 188.

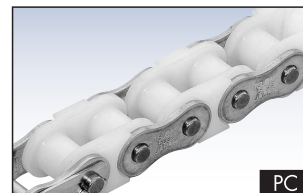

■ PC-SY (Super Chemical Resistance Series)

Poly Steel Chain with superb chemical resistance.

The pins and outer plates of these chains are made of titanium, while the inner plates are of a special engineered plastic (matte white); therefore they are suited for applications in which PC Chains have insufficient corrosion resistance. They can be used in temperatures of -20 to 80°C. For details on corrosion resistance selection, see pg. 188. Bear in mind when making your selection that maximum allowable load is about 60% that of PC Chains.

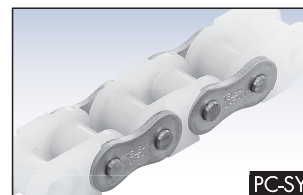

■ BS-PC (BS Standard Series)

Poly Steel Chain that conforms to BS standards.

Curved Stainless Steel Roller Chains

These roller chains have a wide sideflex due to its original pin / bush construction and the large clearance between its plates. Curved transmission is easy using RS-type standard sprockets.



⚠ Pre-Delivery Lubrication

- SS Series and NS Series Stainless Steel Roller Chains, Titanium Roller Chains, and Curved Stainless Steel Roller Chains are not lubricated before delivery. Always lubricate your chain before use, except when chains are to be used submerged in or in contact with water. If chains are not lubricated for use, then they may suffer articulation problems prematurely.
- The maximum allowable load is calculated under lubricated conditions (including water lubricant).

*RS11-SS-1 chain is lubricated.

SS Series

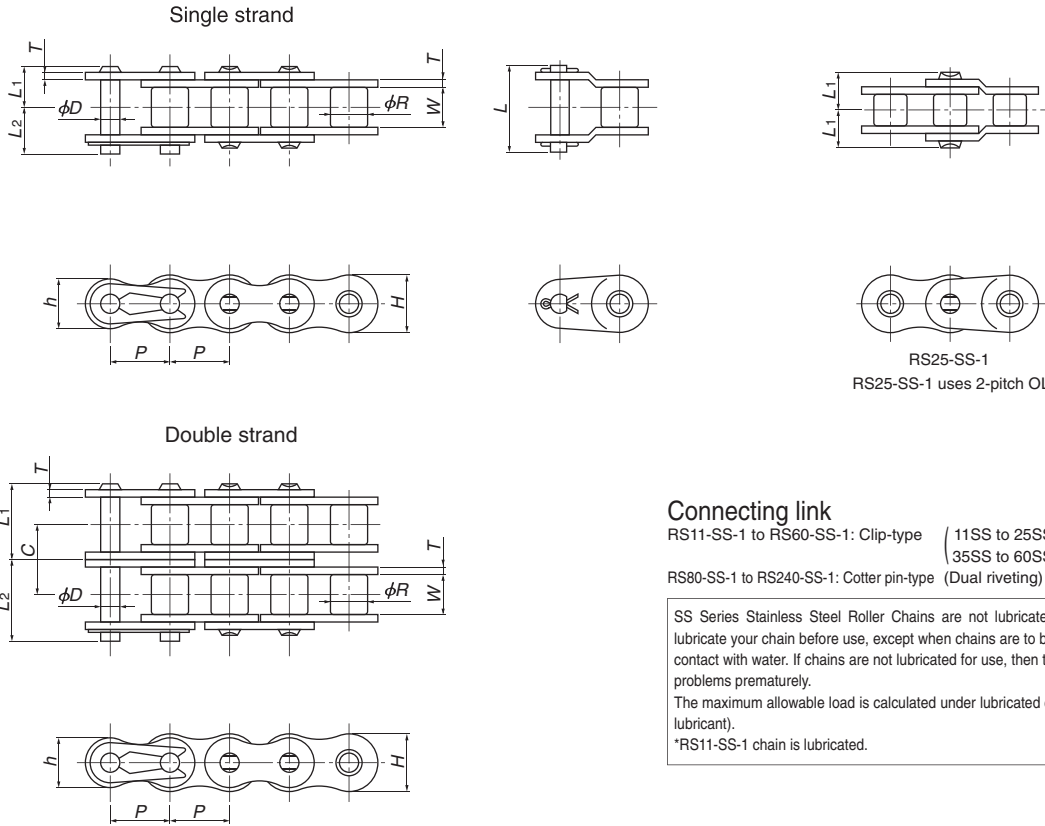

Connecting link

RS11-SS-1 to RS60-SS-1: Clip-type (11SS to 25SS: Dual riveting
35SS to 60SS: Button-head riveting)
RS80-SS-1 to RS240-SS-1: Cotter pin-type (Dual riveting)

SS Series Stainless Steel Roller Chains are not lubricated before delivery. Always lubricate your chain before use, except when chains are to be used submerged in or in contact with water. If chains are not lubricated for use, then they may suffer articulation problems prematurely.
The maximum allowable load is calculated under lubricated conditions (including water lubricant).
*RS11-SS-1 chain is lubricated.

TSUBAKI Chain Number	Number of Strands	Pitch P	Roller Diameter R	Inner Width of Inner Link W	Plates			Pins				Transverse Pitch C	Maximum Allowable Load kN {kgf}	Approximate Mass kg/m	Links Per Unit	
					Thickness T	Height H	Height h	Diameter D	L1 + L2	L1	L2					Offset Pin Length L
A140001	RS11-SS-1	3.7465	※2.285	1.83	0.38	3.5	3.5	1.57	5.44	2.275	3.165	—	—	0.05 {5}	0.052	134
A140002	RS25-SS-1	6.35	※3.30	3.18	0.75	5.84	5.05	2.31	8.6	3.8	4.8	—	—	0.12 {12}	0.14	160
A140003	RS35-SS-1	9.525	※5.08	4.78	1.25	9.0	7.8	3.59	12.9	6.05	6.85	14.7	—	0.26 {27}	0.33	320
A140004	RS40-SS-1	12.70	7.92	7.95	1.5	12.0	10.4	3.97	17.9	8.25	9.65	18.6	—	0.44 {45}	0.64	240
A140005	RS40-SS-2								32.6	15.25	17.35	33.5	14.4	0.88 {90}	1.27	
A140006	RS50-SS-1	15.875	10.16	9.53	2.0	15.0	13.0	5.09	22.3	10.3	12.0	23.9	—	0.69 {70}	1.04	192
A140007	RS50-SS-2								40.4	19.15	21.25	41.8	18.1	1.37 {140}	2.07	
A140008	RS60-SS-1	19.05	11.91	12.70	2.4	18.1	15.6	5.96	27.6	12.85	14.75	29.4	—	1.03 {105}	1.53	160
A140009	RS60-SS-2								50.4	24.25	26.15	52.6	22.8	2.06 {210}	3.04	
A140010	RS80-SS-1	25.40	15.88	15.88	3.2	24.1	20.8	7.94	35.7	16.25	19.45	39.0	—	1.77 {180}	2.66	120
A140011	RS80-SS-2								64.8	30.90	33.90	68.05	29.3	3.53 {360}	5.30	
A140012	RS100-SS-1	31.75	19.05	19.05	4.0	30.1	26.0	9.54	42.6	19.75	22.85	45.7	—	2.55 {260}	4.01	96
A140013	RS100-SS-2								78.5	37.70	40.80	81.6	35.8	5.10 {520}	7.99	
A14	RS120-SS-1	38.10	22.23	25.40	5.0	36.2	31.2	11.11	55.55	25.75	29.80	59.7	—	3.82 {390}	6.13	80
A14	RS120-SS-2								100.6	48.35	52.25	104.9	45.4	7.65 {780}	12.22	
A14	RS140-SS-1	44.45	25.40	25.40	6.0	42.2	36.4	12.71	61.1	28.15	32.95	66.2	—	4.61 {470}	7.91	68
A14	RS140-SS-2								110.0	52.70	57.30	114.6	48.9	9.22 {940}	15.77	
A14	RS160-SS-1	50.80	28.58	31.75	7.0	48.2	41.6	14.29	72.1	33.55	38.55	77.3	—	6.37 {650}	10.86	60
A14	RS160-SS-2				6.4				127.2	66.05	61.15	132.2	58.5	12.7 {1300}	21.66	
A14	RS180-SS-1	57.15	35.71	35.72	7.15	54.2	46.8	17.46	78.1	35.65	42.45	84.9	—	8.55 {872}	13.45	54
A14	RS200-SS-1	63.50	39.68	38.10	8.0	60.3	52.0	19.85	84.8	39.5	45.3	90.8	—	10.8 {1100}	16.54	48
A14	RS240-SS-1	76.20	47.63	47.63	10.0	72.4	62.4	23.81	105.5	49.0	56.5	113.2	—	15.7 {1600}	24.50	40

Note: 1. Chains marked with an ※ are rollerless - - bush diameter given.
2. Multi-strand stainless steel chains and sprockets are made-to-order. Be aware that chain sizes greater than RS120-SS-1 have a different plate thickness than RS Roller Chains.

Before Use Standard Roller Chains Lubrication-Free Roller Chains Heavy Duty Roller Chains Corrosion Resistant Roller Chains Specialty Roller Chains Sprockets Pin Gear Drives Accessories Selection Handling

NS Series

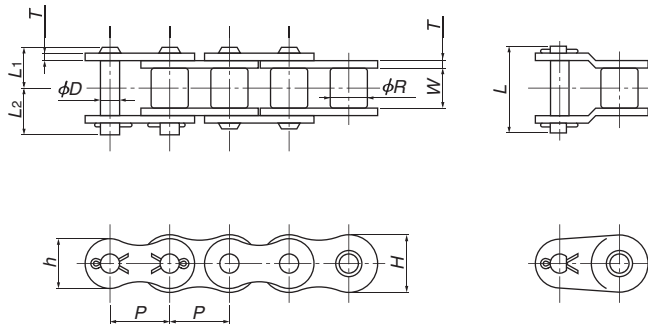

Connecting link

- RS25-NS-1: Clip-type
- RS80-NS-1: Cotter pin-type (SUS304)
- RS35-NS-1 to RS60-NS-1: Cotter pin-type (SUS316)

NS Series Stainless Steel Roller Chains are not lubricated before delivery. Always lubricate your chain before use, except when chains are to be used submerged in or in contact with water. If chains are not lubricated for use, then they may suffer articulation problems prematurely.

TSUBAKI Chain Number	Pitch P	Roller Diameter R	Inner Width of Inner Link W	Plates			Pins					Maximum Allowable Load $kN\{kgf\}$	Approximate Mass kg/m	Links Per Unit
				Thickness T	Height H	Height h	Diameter D	$L_1 + L_2$	L_1	L_2	Offset Pin Length L			
RS25-NS-1	6.35	※3.30	3.18	0.75	5.85	5.05	2.31	8.6	3.8	4.5	(7.6)	0.12 {12}	0.14	160
RS35-NS-1	9.525	※5.08	4.78	1.25	9.0	7.8	3.59	13.0	5.85	7.15	14.7	0.26 {27}	0.33	320
RS40-NS-1	12.70	7.92	7.95	1.5	12.0	10.4	3.97	17.9	8.25	9.65	18.6	0.44 {45}	0.64	240
RS50-NS-1	15.875	10.16	9.53	2.0	15.0	13.0	5.09	22.2	10.3	11.9	23.9	0.69 {70}	1.04	192
RS60-NS-1	19.05	11.91	12.70	2.4	18.1	15.6	5.96	28.1	12.85	15.25	29.4	1.03{105}	1.53	160
RS80-NS-1	25.40	15.88	15.88	3.2	24.1	20.8	7.94	35.7	16.25	19.45	39.0	1.77{180}	2.66	120

Note: 1. Chains marked with an * are rollerless - - bush diameter given.
 2. RS25-NS-1 uses only 2POL.

AS Series

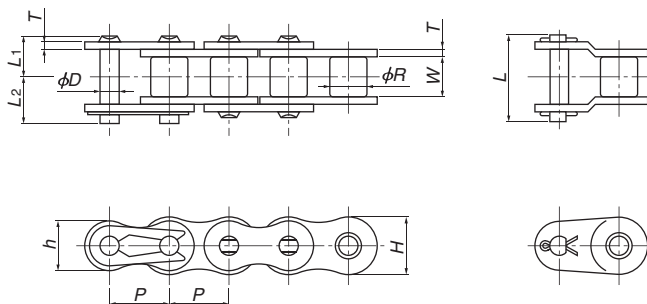

Connecting link

- RS40-AS-1 to RS60-AS-1: Clip-type
- RS80-AS-1: Cotter pin-type

TSUBAKI Chain Number	Pitch P	Roller Diameter R	Inner Width of Inner Link W	Plates			Pins					Maximum Allowable Load $kN\{kgf\}$	Approximate Mass kg/m	Links Per Unit
				Thickness T	Height H	Height h	Diameter D	$L_1 + L_2$	L_1	L_2	Offset Pin Length L			
RS40-AS-1	12.70	7.92	7.95	1.5	12.0	10.4	3.97	18.2	8.25	9.95	18.6	0.69{70}	0.64	240
RS50-AS-1	15.875	10.16	9.53	2.0	15.0	13.0	5.09	22.3	10.3	12.0	23.9	1.03{105}	1.04	192
RS60-AS-1	19.05	11.91	12.70	2.4	18.1	15.6	5.96	27.6	12.85	14.75	29.4	1.57{160}	1.53	160
RS80-AS-1	25.40	15.88	15.88	3.2	24.1	20.8	7.94	35.7	16.25	19.45	39.0	2.65{270}	2.66	120

LSC Series Stainless Steel Drive Chain

Tsubaki's LSC Series Stainless Steel Drive Chain provides long life not only in dry environments, but also in contact with water or even underwater. Stainless steel chains are an ideal choice in production lines with a washdown process; in the food industry, where water is often part of the production process; in sanitary and pharmaceutical packaging industries; and in a wide variety of other industries.

Uses a special plastic sleeve for the bearing

Features black engineering plastic sleeves between SS Series stainless steel chain pins and bushes. Rollers can be either stainless steel or engineering plastic (white).

Material

Base chain: 18-8 stainless steel (SUS 304 equivalent) for pins, bushes, and plates
 Rollers: 18-8 stainless steel (SUS 304 equivalent) or engineering plastic (white)
 Sleeves: Engineering plastic (black)

Basic construction

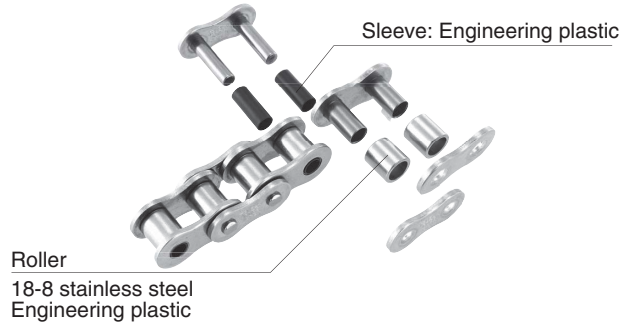

Features

Long life

..... Stainless steel rollers provide over four times the wear life of SS Series Stainless Steel Chain. Engineering plastic rollers provide over ten times the wear life.

Quiet and lightweight

..... 15% lighter
 7-10dB quieter
*Comparison between LSC Chain with engineering plastic rollers and SS Series chain.

Clean

..... Ideal for equipment in situations where cleanliness is important.

Operating temperature range

..... -20°C to 100°C (with stainless steel rollers)
 -20°C to 80°C (with engineering plastic rollers)

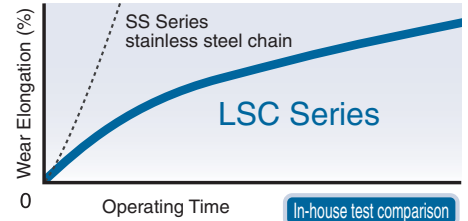

Wear life comparison with stainless steel chain (18-8 stainless steel, SUS304 equiv.)

Operating environment	Roller type	
	Stainless steel	Engineering plastic
Dry	Over 4x the wear life	Over 10x the wear life
In contact with water, underwater	Over 4x the wear life	_____

Engineering plastic rollers may suffer premature wear when in contact with water or underwater. Tsubaki (In-house test comparison) does not recommend their use in these environments.

Caution when disassembling or connecting LSC Series Chain

When disassembling the chain, be careful that the engineering plastic sleeves (black pipe) between the pins and bushes do not fall out. Also, ensure that the sleeves are present between the pins and bushes when connecting.

Caution Clean regularly to remove any black dust that may appear.

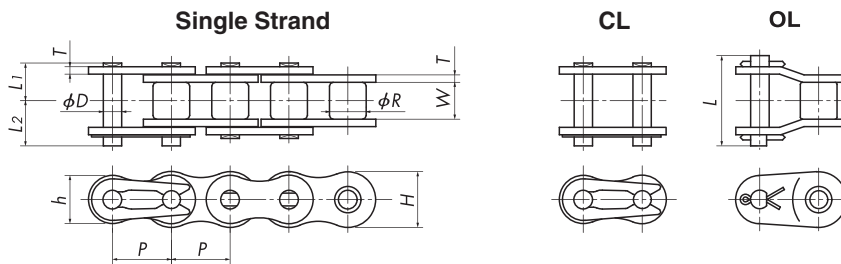

Connecting Link

RS40 – RS60 : Clip type
 RS80 : Cotter pin type

TSUBAKI Chain Number		Pitch P	Roller Dia. R	Inner Link Inner Width W	Plate			Pin				
Steel Rollers	Engineering Plastic Rollers				T	H	h	D	L ₁ +L ₂	L ₁	L ₂	Offset Pin Length L
RS40-LSC-1	RS40SP-LSC-1	12.70	7.92	7.95	1.5	12.0	10.4	3.97	18.2	8.25	9.95	18.6
RS50-LSC-1	RS50SP-LSC-1	15.875	10.16	9.53	2.0	15.0	13.0	5.09	22.3	10.3	12.0	23.9
RS60-LSC-1	RS60SP-LSC-1	19.05	11.91	12.70	2.4	18.1	15.6	5.96	27.6	12.85	14.75	29.4
RS80-LSC-1	RS80SP-LSC-1	25.40	15.88	15.88	3.2	24.1	20.8	7.94	35.5	16.25	19.25	39.0

TSUBAKI Chain Number		Maximum Allowable Load kN{kgf}		Approximate Mass kg/m		No. of Links per Unit
Steel Rollers	Engineering Plastic Rollers	Steel Rollers	Engineering Plastic Rollers	Steel Rollers	Engineering Plastic Rollers	
RS40-LSC-1	RS40SP-LSC-1	0.44{45}	0.23{23}	0.64	0.50	240
RS50-LSC-1	RS50SP-LSC-1	0.69{70}	0.34{35}	1.04	0.88	192
RS60-LSC-1	RS60SP-LSC-1	1.03{105}	0.54{55}	1.53	1.27	160
RS80-LSC-1	RS80SP-LSC-1	1.77{180}	—	2.66	—	120

*Made-to-order product.

Before Use | Standard Roller Chains | Lube-Free Roller Chains | Heavy Duty Roller Chains | Corrosion Resistant Roller Chains | Specialty Roller Chains | Sprockets | Pin Gear Drives | Accessories | Selection | Handling

NP Series

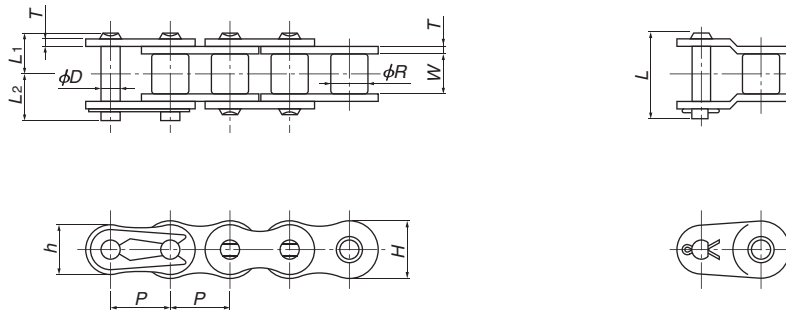

Connecting link

RS25-NP-1 to RS60-NP-1: Clip-type (Dual riveting)
 RS80-NP-1 to RS120-NP-1: Cotter pin-type (Dual riveting)

RS25-NP-1 uses 2POL.

TSUBAKI Chain Number	Pitch <i>P</i>	Roller Diameter <i>R</i>	Inner Width of Inner Link <i>W</i>	Plates			Pins					Pin type
				Thickness <i>T</i>	Height <i>H</i>	Height <i>h</i>	Diameter <i>D</i>	<i>L</i> ₁ + <i>L</i> ₂	<i>L</i> ₁	<i>L</i> ₂	Offset Pin Length <i>L</i>	
RS25-NP-1	6.35	※3.30	3.18	0.75	5.84	5.05	2.31	8.3	3.8	4.5	7.6	Riveting
RS35-NP-1	9.525	※5.08	4.78	1.25	9.0	7.8	3.59	12.7	5.85	6.85	13.5	//
RS40-NP-1	12.70	7.92	7.95	1.5	12.0	10.4	3.97	18.2	8.25	9.95	18.0	//
RS50-NP-1	15.875	10.16	9.53	2.0	15.0	13.0	5.09	22.2	10.3	11.9	22.5	//
RS60-NP-1	19.05	11.91	12.70	2.4	18.1	15.6	5.96	27.6	12.85	14.75	28.2	//
RS80-NP-1	25.40	15.88	15.88	3.2	24.1	20.8	7.94	35.5	16.25	19.25	36.0	//
RS100-NP-1	31.75	19.05	19.05	4.0	30.1	26.0	9.54	42.6	19.75	22.85	44.4	Cotter pin
RS120-NP-1	38.10	22.23	25.40	4.8	36.2	31.2	11.11	53.8	24.9	28.9	45.4	//

TSUBAKI Chain Number	Minimum Tensile Strength kN {kgf}	Average Tensile Strength kN {kgf}	Maximum Allowable Load kN {kgf}	Approximate Mass kg/m	Number of Links Per Unit
RS25-NP-1	4.12 {420}	4.7 {480}	0.64 {65}	0.14	160
RS35-NP-1	9.81 {1000}	11.3 {1150}	1.86 {190}	0.33	320
RS40-NP-1	17.7 {1800}	19.1 {1950}	3.04 {310}	0.64	240
RS50-NP-1	28.4 {2900}	31.4 {3200}	5.39 {550}	1.04	192
RS60-NP-1	40.2 {4100}	44.1 {4500}	7.26 {740}	1.53	160
RS80-NP-1	71.6 {7300}	78.5 {8000}	12.7 {1300}	2.66	120
RS100-NP-1	107 {10900}	118 {12000}	19.1 {1950}	3.99	96
RS120-NP-1	148 {15100}	167 {17000}	25.5 {2600}	5.93	80

Chains marked with an * are rollerless - - bush diameter given.
 Note: 1. Maximum allowable load when using a one-pitch offset link (OL) is 65% of the above.

⚠ Precautions in Usage

1. Do not use surface-treated drive chains if the chains will come in direct contact with food or where flaked coating can contaminate food.
2. Though nickel is not subject to the Food Sanitation Law or Industrial Safety and Health Law, use with caution.

NEP Series

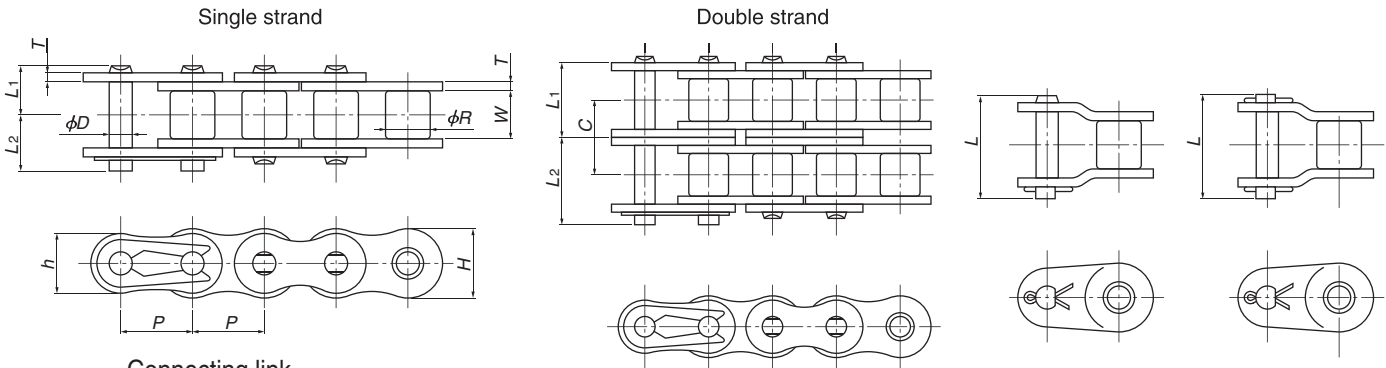

Connecting link

RS35 to RS60: Clip-type
 RS80 or larger: Cotter pin-type
 All sizes of NEP chains are riveted (RP).

TSUBAKI Chain Number	Pitch <i>P</i>	Roller Diameter <i>R</i>	Inner Width of Inner Link <i>W</i>	Plates			Pins				Transverse Pitch <i>C</i>	
				Thickness <i>T</i>	Height <i>H</i>	Height <i>h</i>	Diameter <i>D</i>	<i>L</i> ₁ + <i>L</i> ₂	<i>L</i> ₁	<i>L</i> ₂		Offset Pin Length <i>L</i>
RS35-NEP-1	9.525	(5.08)	4.78	1.25	9.0	7.8	3.59	12.7	5.85	6.85	13.5	—
RS40-NEP-1	12.70	7.92	7.95	1.5	12.0	10.4	3.97	18.2	8.25	9.95	18.0	—
RS40-NEP-2								32.6	15.45	17.15	33.5	14.4
RS50-NEP-1	15.875	10.16	9.53	2.0	15.0	13.0	5.09	22.2	10.3	11.9	22.6	—
RS50-NEP-2								40.5	19.35	21.15	41.8	18.1
RS60-NEP-1	19.05	11.91	12.70	2.4	18.1	15.6	5.96	27.6	12.85	14.75	28.2	—
RS60-NEP-2								50.5	24.25	26.25	52.6	22.8
RS80-NEP-1	25.40	15.88	15.88	3.2	24.1	20.8	7.94	35.5	16.25	19.25	38.2	—
RS80-NEP-2								64.8	30.9	33.9	67.5	29.3
RS100-NEP-1	31.75	19.05	19.05	4.0	30.1	26.0	9.54	42.6	19.75	22.85	45.7	—
RS100-NEP-2								78.5	37.7	40.8	81.5	35.8
RS120-NEP-1	38.10	22.23	25.40	4.8	36.2	31.2	11.11	53.8	24.9	28.9	57.8	—
RS140-NEP-1	44.45	25.40	25.40	5.6	42.2	36.4	12.71	58.6	26.9	31.7	63.4	—
RS160-NEP-1	50.80	28.58	31.75	6.4	48.2	41.6	14.29	68.7	31.85	36.85	73.6	—

TSUBAKI Chain Number	Minimum Tensile Strength kN{kgf}	Average Tensile Strength kN{kgf}	Maximum Allowable Load kN{kgf}	Approximate Mass kg/m	Number of Links Per Unit
RS35-NEP-1	9.81{1000}	11.3{1150}	2.16{220}	0.33	320
RS40-NEP-1	17.1{1800}	19.1{1950}	3.63{370}	0.64	
RS40-NEP-2	35.3{3600}	38.2{3900}	6.18{630}	1.27	240
RS50-NEP-1	28.4{2900}	31.4{3200}	6.37{650}	1.04	
RS50-NEP-2	56.9{5800}	62.8{6400}	10.7{1100}	2.07	192
RS60-NEP-1	40.2{4100}	44.1{4500}	8.83{900}	1.53	
RS60-NEP-2	80.4{8200}	88.3{9000}	15.0{1530}	3.04	160
RS80-NEP-1	71.6{7300}	78.5{8000}	14.7{1500}	2.66	
RS80-NEP-2	143{14600}	157{16000}	25.0{2550}	5.27	120
RS100-NEP-1	107{10900}	118{12000}	22.6{2300}	3.99	
RS100-NEP-2	214{21800}	235{24000}	38.3{3910}	7.85	96
RS120-NEP-1	148{15100}	167{17000}	30.4{3100}	5.93	
RS140-NEP-1	193{19700}	216{22000}	40.2{4100}	7.49	68
RS160-NEP-1	255{26000}	279{28500}	53.0{5400}	10.10	60

- Note: 1. Maximum allowable load when using a one-pitch offset link (OL) is 65% of the above.
 2. RS35-NEP is a bushed chain; it does not have rollers.
 3. Multi-strand RS35-NEP is not available.
 4. 2-pitch offset links are not available.
 5. Please contact a Tsubaki representative for information regarding RS180 and above chains.

⚠ Precautions in Usage

- Depending on the conditions of use, if steel roller chains are used with stainless steel sprockets, the roller may prematurely wear due to galvanic corrosion. Please avoid this set up as much as possible.
- Compared to single-strand chain, the inner link of multi-strand chain is slightly less corrosion resistant (based on in-house testing).

APP Series

Outstanding performance in atmospheres conducive to pitting corrosion

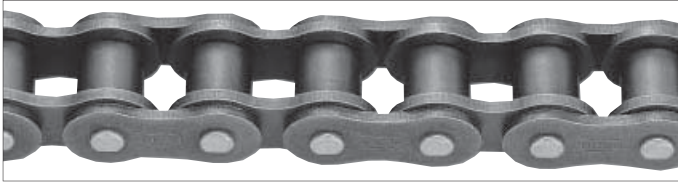

Pins are treated with a special surface treatment to protect against pitting corrosion that leads to fatigue breakage, thus preventing strength loss. This treatment is highly effective in environments that readily promote corrosion, such as outdoors or in coastal applications.

Note: Pitting is a type of localized corrosion affecting metal surfaces. Pits form toward the interior, and if pitting occurs on pin surfaces, that pin can quickly lead to fatigue breakage and chain failure.

■ Features

① **No strength loss!**

Same as standard steel chain.

② **Eco-friendly chrome-free!**

Special surface treatment does not use hazardous hexavalent chromium.

■ Example applications

APP Chains are ideal for atmospheres that readily promote corrosion.

■ Outdoor uses

■ Coastal or riverside uses

■ When regular lubrication is difficult

● Bucket elevators

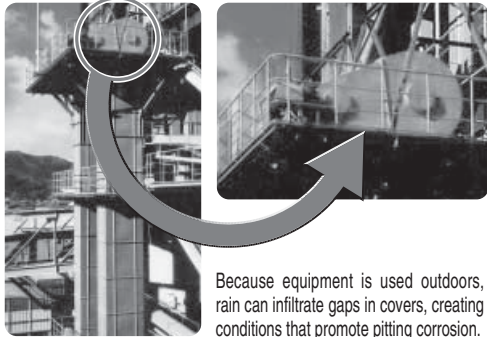

Because equipment is used outdoors, rain can infiltrate gaps in covers, creating conditions that promote pitting corrosion.

● Transfer cranes and other port machinery

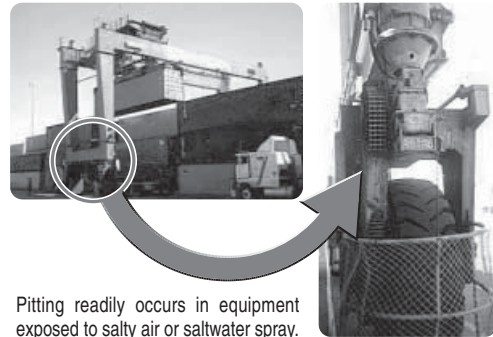

Pitting readily occurs in equipment exposed to salty air or saltwater spray.

■ Examples of fatigue breakage caused by pitting corrosion

Chain: RS240 Equipment: Port container carrier

Pitting corrosion of the pin due to insufficient lubrication (effects of salty air and saltwater) and corrosive atmosphere - - Fatigue breakage

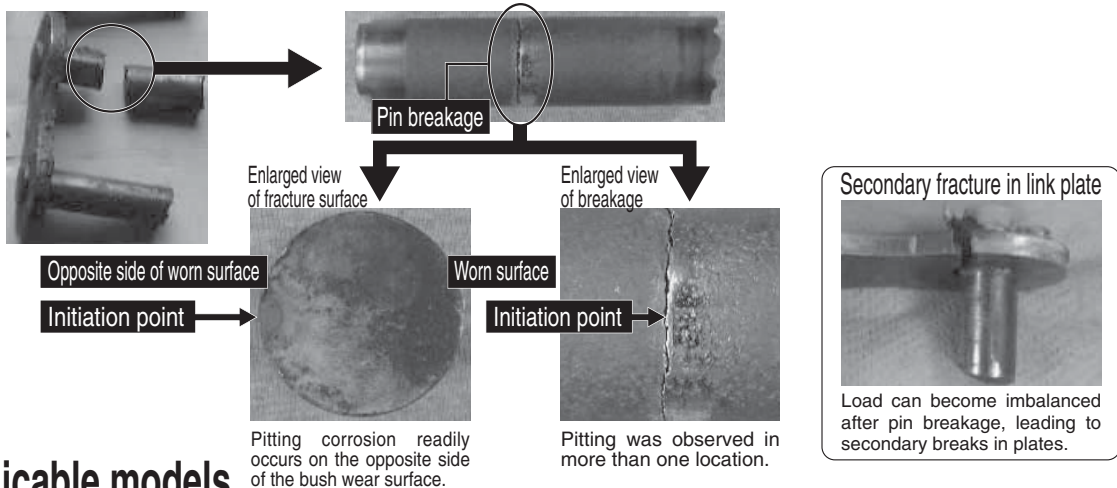

■ Applicable models

■ Single/Double Strand RS Roller Chain

■ Single Strand Heavy Duty Roller Chain

(For other models, contact a Tsubaki representative.)

Except for the surface-treated pins, dimensions and other specifications are the same as other roller chains.

■ Chain number

RS80-APP-1

RS80-SUP-APP-1-F or M

RS80-HT-APP-1

Note: Select connecting link (CL).

Anti-Pitting Roller Chain

Before Use Standard Roller Chains Lube-Free Roller Chains Heavy Duty Roller Chains Corrosion Resistant Roller Chains Specialty Roller Chains Sprockets Pin Gear Drives Accessories Selection Handling

Titanium Roller Chains

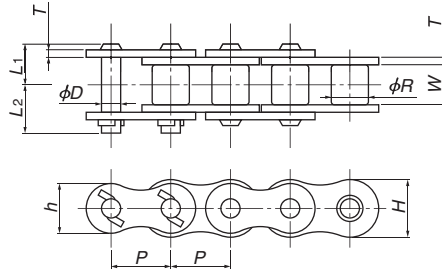

Titanium Roller Chains are not lubricated before delivery. Always lubricate your chain before use, except when chains are to be used submerged in or in contact with water. If chains are not lubricated for use, then they may suffer articulation problems prematurely.

Model	Pitch P	Roller Diameter R	Inner Width of Inner Link W	Plates			Pins			Maximum Allowable Load $kN\{kgf\}$	Approximate Mass kg/m	Links Per Unit	
				Thickness T	Height H	Height h	Diameter D	$L_1 + L_2$	L_1				L_2
RS35-TI-1	9.525	※5.08	4.78	1.25	9.0	7.8	3.59	13.2	6.05	7.15	0.26{27}	0.19	320
RS40-TI-1	12.70	7.92	7.95	1.5	12.0	10.4	3.97	18.35	8.25	10.1	0.44{45}	0.37	240

Note: 1. The figure shown is the bush diameter. 2. Connecting links (CL) use Z-pins. 3. Offset links are not available.

Poly Steel Chains

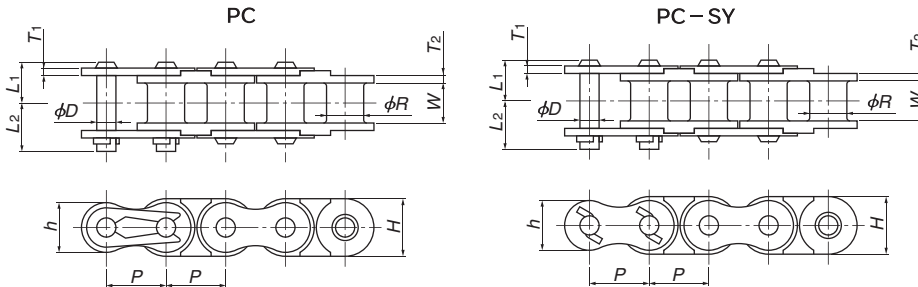

- Recheck chain tension when replacing stainless steel chains with Poly Steel chains.
- No offset links available.

PC Specification

TSUBAKI Chain Number	Pitch P	Bush Diameter R	Inner Width of Inner Link W	Plates				Pins				Maximum Allowable Load $kN\{kgf\}$	Approximate Mass kg/m	Links Per Unit
				Thickness T_1	Thickness T_2	Height H	Height h	Diameter D	$L_1 + L_2$	L_1	L_2			
RS25-PC-1	6.35	3.30	3.18	0.75	1.3	6.0	5.05	2.31	10.0	4.5	5.5	0.08 {8}	0.095	160
RS35-PC-1	9.525	5.08	4.78	1.25	2.2	9.0	7.8	3.59	14.7	6.85	7.85	0.18{18}	0.22	320
RS40-PC-1	12.70	7.92	7.95	1.5	1.5	12.0	10.4	3.97	18.2	8.25	9.95	0.44{45}	0.39	240
RS50-PC-1	15.875	10.16	9.53	2.0	2.0	15.0	13.0	5.09	22.3	10.3	12.0	0.69{70}	0.58	192
RS60-PC-1	19.05	11.91	12.70	2.4	2.4	18.1	15.6	5.96	27.6	12.85	14.75	0.88{90}	0.82	160

PC-SY Specification

TSUBAKI Chain Number	Pitch P	Bush Diameter R	Inner Width of Inner Link W	Plates				Pins				Maximum Allowable Load $kN\{kgf\}$	Approximate Mass kg/m	Links Per Unit
				Thickness T_1	Thickness T_2	Height H	Height h	Diameter D	$L_1 + L_2$	L_1	L_2			
RS40-PC-SY-1	12.70	7.92	7.95	1.5	1.5	12.0	10.4	3.97	18.35	8.25	10.1	0.25{25}	0.39	240
RS50-PC-SY-1	15.875	10.16	9.53	2.0	2.0	15.0	13.0	5.09	22.3	10.3	12.0	0.39{40}	0.58	192
RS60-PC-SY-1	19.05	11.91	12.70	2.4	2.4	18.1	15.6	5.96	28.1	12.85	15.25	0.49{50}	0.82	160

BS-PC Specification

TSUBAKI Chain Number	Pitch P	Bush Diameter R	Inner Width of Inner Link W	Plates				Pins				Maximum Allowable Load $kN\{kgf\}$	Approximate Mass kg/m	Links Per Unit (3m)
				Thickness T_1	Thickness T_2	Height H	Height h	Diameter D	$L_1 + L_2$	L_1	L_2			
RF06B-PC-1	9.525	6.35	5.72	1.0	1.3	8.2	8.2	3.28	13.75	6.5	7.25	0.20{20}	0.23	320
RS08B-PC-1	12.70	8.51	7.75	1.5	1.6	12.0	11.4	4.45	18.4	8.35	10.05	0.46{47}	0.4	240
RS10B-PC-1	15.875	10.16	9.65	1.5	1.5	14.7	13.7	5.08	20.8	9.55	11.25	0.53{54}	0.52	192
RS12B-PC-1	19.05	12.07	11.68	1.8	1.8	16.1	15.6	5.72	24.1	11.1	13.0	0.70{71}	0.65	160

Before Use Standard Roller Chains Lube-Free Roller Chains Heavy Duty Roller Chains Corrosion Resistant Roller Chains Specialty Roller Chains Sprockets Pin Gear Drives Accessories Selection Handling

Corrosion Resistant Roller Chains

Low Noise Roller Chains

Tsubaki's uniquely structured spring rollers are used for the chain rollers. When Tsubaki's Low Noise Roller Chain engages the sprocket, the spring roller deforms and absorbs the force of impact, reducing impact noise between chain and sprocket for lower noise levels. Compared with Tsubaki's standard RS Roller Chain (pre-lubricated), noise levels of Low Noise Roller Chain are 6 - 8 dB lower. (In-house comparison testing)

Benefits of noise reduction

- Less factory noise for a better work environment.
- A low noise function is added to machinery and equipment used for manufacturing, and contributes to upgrading and improving their overall image.
- Belts were considered as a countermeasure for noise; however, there are many limitations in terms of application, strength and overall cost. Low Noise Chain is the perfect countermeasure.
- Recommended for applications where silence is a major concern, such as stage lifts used in theaters.

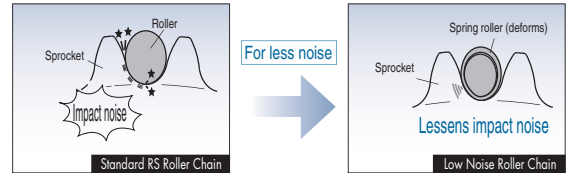

Features

Low noise

Noise levels reduced by 6 dB to 8 dB compared with the RS Roller Chain.

Interchangeability

Dimensional specifications are the same as for RS Roller Chain.

Note: There are limits on drive power; check kW ratings tables on pgs. 90–92.

Selection

Use the General Selection Method (the kilowatt ratings tables on pgs. 90–92). See selection pages for more details.

Operating temperatures

–10°C to 60°C

Allowable chain speed

200 m / min (max.)

Sprocket

Can be used with standard RS sprockets.

If the chain cannot be sufficiently lubricated, choose sprockets with hardened teeth specifications.

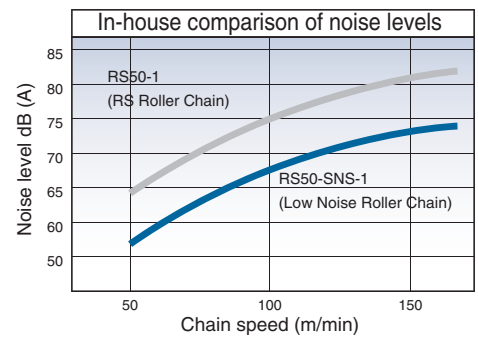

- Test conditions
Chain tension: 3.29 kN
Lubrication: Pre-lubrication only
Measurement position: 300 mm from drive sprocket

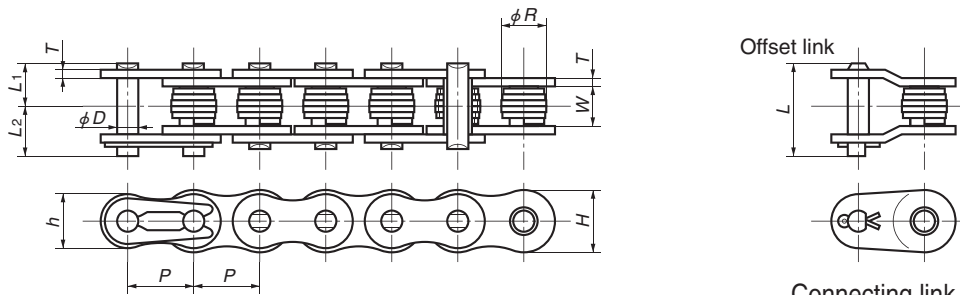

Connecting link
RS80-SNS-1: Cotter pin-type

TSUBAKI Chain Number	Pitch P	Roller Diameter R	Inner Width of Inner Link W	Plates			Pins				
				Thickness T	Height H	Height h	Diameter D	$L_1 + L_2$	L_1	L_2	L
RS40-SNS-1	12.70	8.5	7.95	1.5	12.0	10.4	3.97	18.2	8.25	9.95	18.0
RS50-SNS-1	15.875	10.8	9.53	2.0	15.0	13.0	5.09	22.3	10.3	12.0	22.5
RS60-SNS-1	19.05	12.6	12.70	2.4	18.1	15.6	5.96	27.6	12.85	14.75	28.2
RS80-SNS-1	25.40	16.8	15.88	3.2	24.1	20.8	7.94	35.5	16.25	19.25	36.0

TSUBAKI Chain Number	Minimum Tensile Strength kN{kgf}	Average Tensile Strength kN{kgf}	Maximum Allowable Load kN{kgf}	Approximate Mass kg/m	Number of Links Per Unit
RS40-SNS-1	17.7{1800}	19.1{1950}	3.63{370}	0.64	240
RS50-SNS-1	28.4{2900}	31.4{3200}	6.37{650}	1.04	192
RS60-SNS-1	40.2{4100}	44.1{4500}	8.83{900}	1.53	160
RS80-SNS-1	71.6{7300}	78.5{8000}	14.7 {1500}	2.66	120

- Note: 1. Maximum allowable load when using 1-pitch offset links (OL) is 65% of the above values.
2. Stocked item.
3. Uses the same connecting link (CL) as RS Roller Chain.

Offset Links (OL)

Product Code	Chain Number
A146043	RS40-SNS-1-OL
A146044	RS50-SNS-1-OL
A146045	RS60-SNS-1-OL
A146046	RS80-SNS-1-OL

Cold Resistant Roller Chains

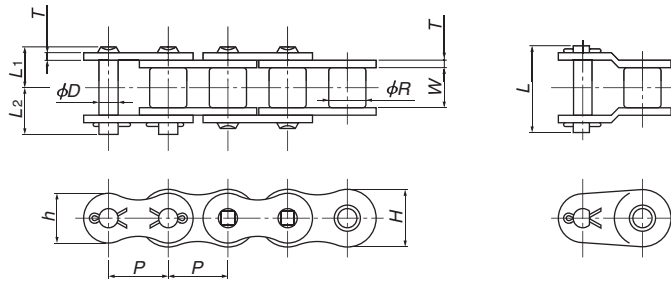

Model	Pitch P	Roller Diameter R	Inner Width of Inner Link W	Plates			Pins				
				Thickness T	Height H	Height h	Diameter D	$L_1 + L_2$	L_1	L_2	Offset Pin Length L
RS35-KT-1	9.525	※5.08	4.78	1.25	9.0	7.8	3.59	12.9	5.85	7.05	13.5
RS40-KT-1	12.70	7.92	7.95	1.5	12.0	10.4	3.97	17.9	8.25	9.65	18.0
RS50-KT-1	15.875	10.16	9.53	2.0	15.0	13.0	5.09	22.2	10.3	11.9	23.7
RS60-KT-1	19.05	11.91	12.70	2.4	18.1	15.6	5.96	28.1	12.85	15.25	28.2
RS80-KT-1	25.40	15.88	15.88	3.2	24.1	20.8	7.94	35.5	16.25	19.25	36.6
RS100-KT-1	31.75	19.05	19.05	4.0	30.1	26.0	9.54	42.6	19.75	22.85	43.7
RS120-KT-1	38.10	22.23	25.40	4.8	36.2	31.2	11.11	53.8	24.9	28.9	55.0
RS140-KT-1	44.45	25.40	25.40	5.6	42.2	36.4	12.71	58.6	26.9	31.7	62.8
RS160-KT-1	50.80	28.58	31.75	6.4	48.2	41.6	14.29	68.7	31.85	36.85	70.2

Model	Minimum Tensile Strength kN{kgf}	Average Tensile Strength kN{kgf}	Maximum Allowable Load kN{kgf}	Approximate Mass kg/m	Number of Links Per Unit
RS35-KT-1	9.81{1000}	11.3{1150}	2.16{220}	0.33	320
RS40-KT-1	17.7 {1800}	19.1{1950}	3.63{370}	0.64	240
RS50-KT-1	28.4 {2900}	31.4{3200}	6.37{650}	1.04	192
RS60-KT-1	40.2 {4100}	44.1{4500}	8.83{900}	1.53	160
RS80-KT-1	71.6 {7300}	78.5{8000}	14.7{1500}	2.66	120
RS100-KT-1	107 {10900}	118 {12000}	22.6{2300}	3.99	96
RS120-KT-1	148 {15100}	167 {17000}	30.4{3100}	5.93	80
RS140-KT-1	193 {19700}	216 {22000}	40.2{4100}	7.49	68
RS160-KT-1	255 {26000}	279 {28500}	53.0{5400}	10.10	60

- Note: 1. Values marked with * are rollerless.
 2. Offset pin shape varies according to size.
 3. Maximum allowable load when using MCL is 80% of the above values.
 4. Maximum allowable load when using 1-pitch offset links (OL) is 65% of the above values.
 5. Normally, chains are coated only with anti-rust oil when shipped. Chain should be lubricated with an oil suitable to the ambient temperature during actual use. Customized models that are coated with a silicon (low temperature) oil are also available.

Curved Stainless Steel Roller Chain

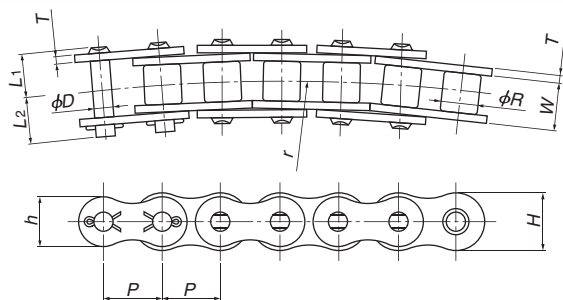

Curved Stainless Steel Roller Chains are not lubricated before delivery. Always lubricate your chain before use, except when chains are to be used submerged in or in contact with water. If chains are not lubricated for use, then they may suffer articulation problems prematurely.

Stainless Steel (SUS304) Specification

Model	Pitch P	Roller Diameter R	Inner Width of Inner Link W	Plates			Pins				Min. Radius r	Maximum Allowable Load kN{kgf}	Approximate Mass kg/m	Links Per Unit
				Thickness T	Height H	Height h	Diameter D	$L_1 + L_2$	L_1	L_2				
RS40-CU-SS-1	12.70	7.92	7.95	1.5	12.0	10.4	3.59	18.1	8.35	9.75	400	0.26 {27}	0.61	240
RS50-CU-SS-1	15.875	10.16	9.53	2.0	15.0	13.0	3.97	22.2	10.15	12.05	500	0.44 {45}	1.01	192
RS60-CU-SS-1	19.05	11.91	12.70	2.4	18.1	15.6	5.09	28.3	13.25	15.05	600	0.69 {70}	1.40	160
RS80-CU-SS-1	25.40	15.88	15.88	3.2	24.1	20.8	5.96	35.0	16.5	18.5	800	1.03{105}	2.47	120

Note: 1. Made-to-order product.



Curved Roller Chain

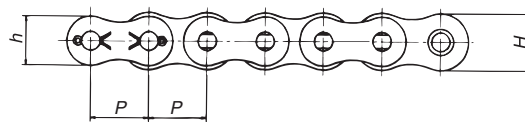
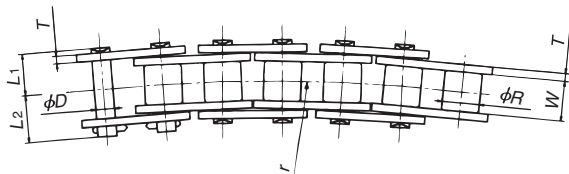

TSUBAKI Chain Number	Pitch P	Roller Diameter R	Inner Width of Inner Link W	Plates			Pins			Tightest lateral bend diameter r	Average Tensile Strength kN{kgf}	Maximum Allowable Load kN{kgf}	Approximate Mass kg/m	Number of Links Per Unit	
				Thickness T	Height H	Height h	Diameter D	L1 + L2	L1						L2
RS40-CU-1	12.70	7.92	7.95	1.5	12.0	10.4	3.97	18.2	8.45	9.75	350	15.5{1580}	1.86{190}	0.61	240
RS50-CU-1	15.875	10.16	9.53	2.0	15.0	13.0	5.09	23.0	10.6	12.4	400	24.1{2460}	2.84{290}	1.01	192
RS60-CU-1	19.05	11.91	12.70	2.4	18.1	15.6	5.96	28.3	13.25	15.05	500	34.9{3560}	4.02{410}	1.40	160
RS80-CU-1	25.40	15.88	15.88	3.2	24.1	20.8	7.94	36.8	16.75	20.05	600	61.6{6280}	6.96{710}	2.47	120

■ Features

Due to Tsubaki's exclusive pin and bush structure, this roller chain has a large sideflex radius thanks to its wide plate-plate clearance. RS sprockets can be used for easy curved drive use.

■ Applications

Curved roller conveyor drive and curved conveyors. Guides are required for curving areas.



Leaf Chains

Construction

Leaf chains are also commonly called balance chains. The most basic type of steel chain, they consist of just plates and pins. Conforming to JIS specifications and suitable for use in low-speed equipment, leaf chains are mainly used for lifting, counterweights, and motion drives.

The plates are connected by pins and take the strain when load is applied. Pins are press fitted to outer plates and riveted. However, a slip fit* is used with middle and inner plates and pins.

The pins pass between the plates and have to withstand the bulk of the shear forces resulting when the chain is under tension and move freely within the inner plate holes when the chain articulates.

*** Slip fit**

When a pin is fitted to a hole, some play is normally allowed. The tolerance range of the hole diameter is larger than the tolerance range for the pin diameter.

*** Press fit**

When a pin is fitted to a hole, the pin is normally tight against the hole. The tolerance range of the hole diameter is less than the tolerance range for the pin diameter.

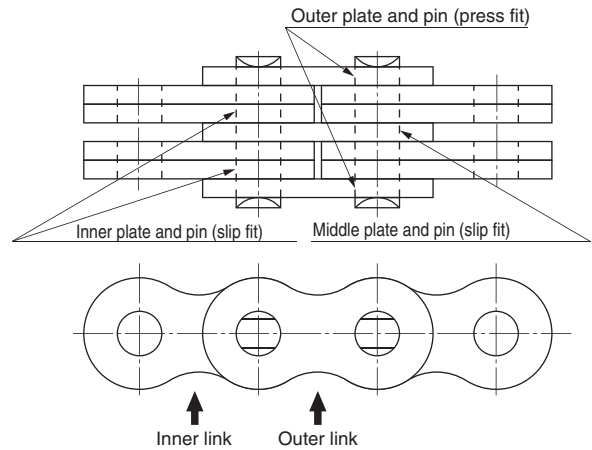

Types

There are two types of leaf chain: AL for light loads and BL for heavy loads. The dimensions and plate configuration for each is different.

AL Type External plate dimensions and thickness are the same as for the outer plates of RS Roller Chain with the same pitch, while the pin diameter is almost the same.

BL Type Plate width is the same as for the inner plates of RS Roller Chain of the same pitch. Plate thickness is the same as for one pitch larger RS roller chain, as is pin diameter.

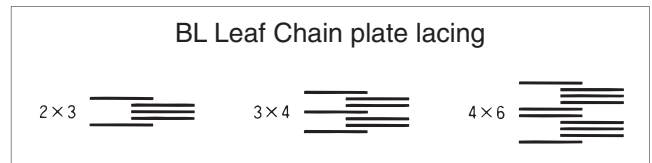
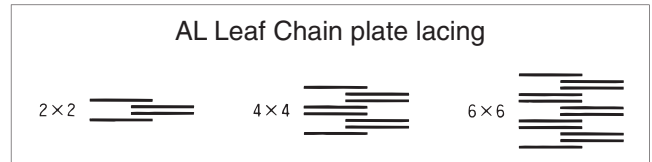

End links

1. Connecting link

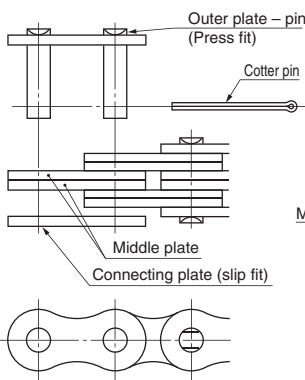

2. End link

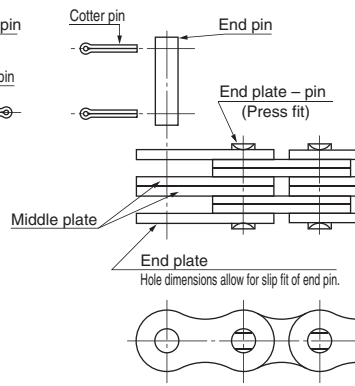

3. Outer link

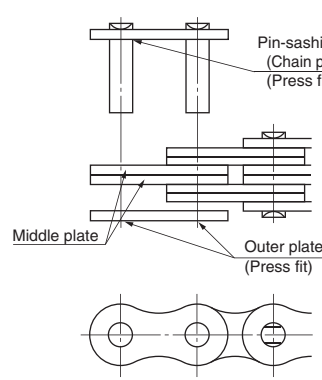

4. Inner link

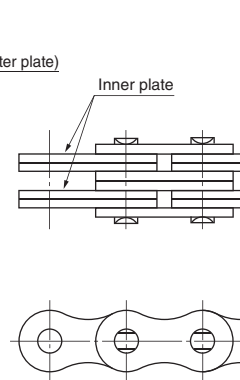

Note: All four types require a slip fit between inner / middle plate holes and pins.

Leaf Chains

Chain number

AL 4 22

Type
(AL or BL)

Lacing
(2 X 2)

Chain pitch (4 corresponds to RS40)

Dimensions

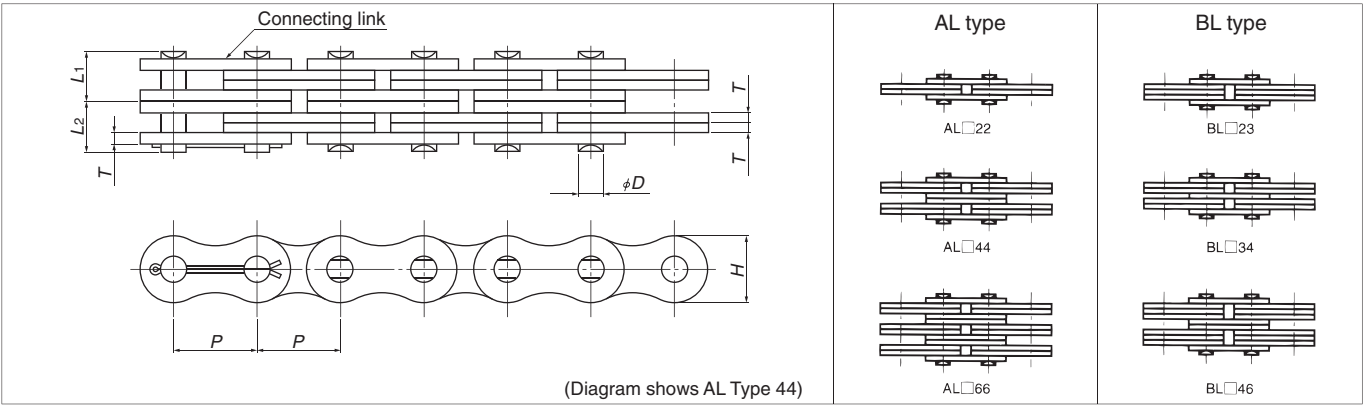

AL Type

TSUBAKI Chain Number	Pitch P	Plate Configuration	Plates		D	Pins		Minimum Tensile Strength kN{kgf}	Approximate Mass kg/m
			H	T		L1	L2		
AL422	12.70	2 × 2	10.4	1.5	3.97	4.20	5.30	16.7{ 1700}	0.38
AL444		4 × 4				7.43	8.52	33.3{ 3400}	0.74
AL466		6 × 6				10.65	11.75	50.5{ 5100}	1.10
AL522	15.875	2 × 2	13.0	2.0	5.08	5.43	6.97	27.5{ 2800}	0.62
AL544		4 × 4				9.68	11.22	54.9{ 5600}	1.22
AL566		6 × 6				13.90	15.45	82.4{ 8400}	1.81
AL622	19.05	2 × 2	15.6	2.4	5.94	6.33	8.22	38.2{ 3900}	0.87
AL644		4 × 4				11.28	13.17	76.5{ 7800}	1.71
AL666		6 × 6				16.23	18.12	115{11700}	2.54
AL822	25.40	2 × 2	20.8	3.2	7.90	8.18	10.97	64.7{ 6600}	1.51
AL844		4 × 4				14.90	17.70	129{13200}	2.98
AL866		6 × 6				21.60	24.40	194{19800}	4.44
AL1022	31.75	2 × 2	26.0	4.0	9.48	10.03	13.22	98.1{10000}	2.69
AL1044		4 × 4				18.35	21.55	196{20000}	5.31
AL1066		6 × 6				26.65	29.85	294{30000}	7.93
AL1222	38.10	2 × 2	31.2	4.8	11.04	12.10	15.80	141{14400}	3.57
AL1244		4 × 4				22.00	25.70	282{28800}	7.07
AL1266		6 × 6				31.93	35.62	424{43200}	10.56
AL1444	44.45	4 × 4	36.4	5.6	12.64	25.65	30.15	373{38000}	10.34
AL1466		6 × 6				37.28	41.77	559{57000}	15.16
AL1644	50.80	4 × 4	41.6	6.4	14.21	29.03	34.02	471{48000}	12.98
AL1666		6 × 6				42.23	47.22	706{72000}	19.41

BL Type

TSUBAKI Chain Number	Pitch P	Plate Configuration	Plates		D	Pins		Minimum Tensile Strength kN{kgf}	Approximate Mass kg/m
			H	T		L1	L2		
BL423	12.70	2 × 3	12.0	2.0	5.08	6.48	8.02	23.5{ 2400}	0.84
BL434		3 × 4				8.60	10.15	35.3{ 3600}	1.13
BL446		4 × 6				11.80	13.35	47.1{ 4800}	1.65
BL523	15.875	2 × 3	15.0	2.4	5.94	7.55	9.45	39.2{ 4000}	1.27
BL534		3 × 4				10.05	11.95	58.8{ 6000}	1.69
BL546		4 × 6				13.75	15.65	78.5{ 8000}	2.40
BL623	19.05	2 × 3	18.1	3.2	7.90	9.88	12.67	63.7{ 6500}	2.04
BL634		3 × 4				13.23	16.02	95.6{ 9750}	2.83
BL646		4 × 6				18.25	21.05	127{13000}	4.01
BL823	25.40	2 × 3	24.1	4.0	9.48	12.10	15.30	103{10500}	3.20
BL834		3 × 4				16.28	19.47	155{15800}	4.44
BL846		4 × 6				22.50	25.70	206{21000}	6.32
BL1023	31.75	2 × 3	30.1	4.8	11.04	14.45	18.15	141{14400}	4.69
BL1034		3 × 4				19.43	23.12	216{22000}	6.55
BL1046		4 × 6				26.85	30.55	282{28800}	9.29
BL1223	38.10	2 × 3	36.2	5.6	12.64	16.95	21.45	186{19000}	6.54
BL1234		3 × 4				22.75	27.25	299{30500}	9.10
BL1246		4 × 6				31.48	35.97	373{38000}	12.01
BL1423	44.45	2 × 3	42.2	6.4	14.21	19.10	24.10	235{24000}	9.06
BL1434		3 × 4				25.70	30.70	387{39500}	11.32
BL1446		4 × 6				35.63	40.62	471{48000}	18.00
BL1623	50.80	2 × 3	48.2	7.2	17.38	21.63	28.22	353{36000}	12.16
BL1634		3 × 4				29.20	35.80	554{56500}	16.95
BL1646		4 × 6				40.53	47.12	706{72000}	24.09

Before Use
 Standard Roller Chains
 Lubrication-Free Roller Chains
 Heavy Duty Roller Chains
 Corrosion Resistant Roller Chains
 Specialty Roller Chains
 Sprockets
 Pin Gear Drives
 Accessories
 Selection
 Handling

Leaf Chains

Clevises

Connecting links, end links, outer links, and inner links can all be used for Leaf Chain end links. When connecting end links (outer link, inner link), use the types of clevises shown below. Contact a Tsubaki representative with special requests.

Connecting Leaf Chain to a clevis

1. Connecting the chain end to a (1) connecting link, (2) end link, or (3) outer link.

Connect an outer-link clevis to the connecting link, end link, or outer link.

2. Connecting the chain end to an (4) inner link.

Connect an inner-link clevis to the end pin.

The end pin length varies according to the external width (W) of the clevis. When ordering, specify the W dimension.

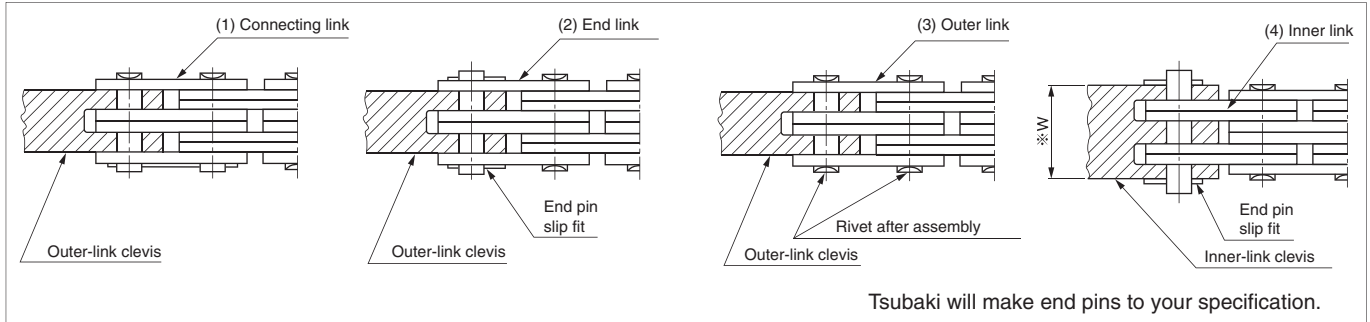

Clevis size and material

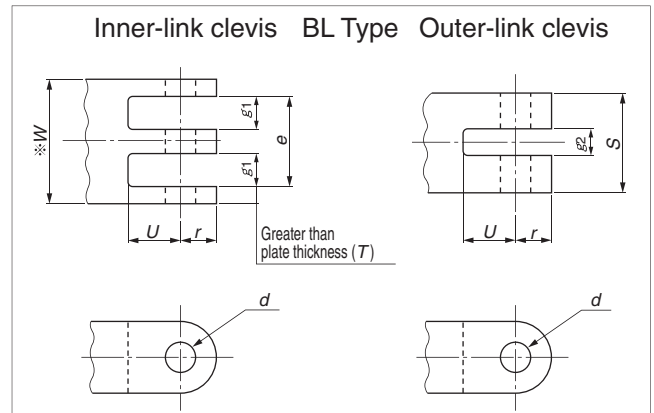
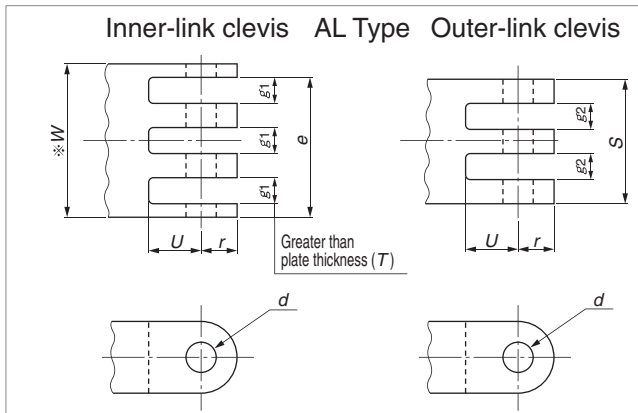

AL Leaf Chain Number	d	r (max.)	U (min.)	$\begin{smallmatrix} +0.2 \\ 0 \end{smallmatrix} e$	$\begin{smallmatrix} +0.1 \\ 0 \end{smallmatrix} \xi_1$	$\begin{smallmatrix} 0 \\ -0.2 \end{smallmatrix} s$	$\begin{smallmatrix} +0.1 \\ 0 \end{smallmatrix} \xi_2$
AL422	4.02	6.3	6.0	—	—	3.1	—
AL444				9.8	3.4	9.5	3.4
AL466				16.2	—	15.9	3.4
AL522	5.13	7.9	7.2	—	—	4.1	—
AL544				12.9	4.4	12.6	4.4
AL566				21.3	—	21.0	4.4
AL622	6.00	9.5	9.0	—	—	4.8	—
AL644				15.0	5.1	14.7	5.1
AL666				24.8	—	24.5	5.1
AL822	7.97	12.7	11.5	—	—	6.4	—
AL844				20.3	6.9	19.8	6.9
AL866				33.7	—	33.2	6.9
AL1022	9.57	15.8	14.5	—	—	8.0	—
AL1044				25.1	8.5	24.6	8.5
AL1066				41.7	—	41.2	8.5
AL1222	11.14	19.0	17.5	—	—	9.6	—
AL1244				29.9	10.1	29.4	10.1
AL1266				49.7	—	49.2	10.1
AL1444	12.74	22.2	20.0	35.1	11.9	34.5	11.9
AL1466				58.3	—	57.7	11.9
AL1644	14.32	25.4	23.0	39.9	13.5	39.2	13.5
AL1666				66.3	—	65.6	13.5

BL Leaf Chain Number	d	r (max.)	U (min.)	$\begin{smallmatrix} +0.2 \\ 0 \end{smallmatrix} e$	$\begin{smallmatrix} +0.1 \\ 0 \end{smallmatrix} \xi_1$	$\begin{smallmatrix} 0 \\ -0.2 \end{smallmatrix} s$	$\begin{smallmatrix} +0.1 \\ 0 \end{smallmatrix} \xi_2$
BL423	5.13	6.3	6.3	—	6.5	6.2	—
BL434				10.7	4.4	10.4	2.3
BL446				17.1	6.5	16.8	4.4
BL523	6.00	7.9	7.9	—	7.6	7.3	—
BL534				12.5	5.1	12.2	2.6
BL546				19.9	7.6	19.6	5.1
BL623	7.97	9.5	9.5	—	10.3	9.8	—
BL634				17.0	6.9	16.5	3.6
BL646				27.0	10.3	26.5	6.9
BL823	9.57	12.7	12.7	—	12.7	12.2	—
BL834				21.0	8.5	20.5	4.4
BL846				33.4	12.7	32.9	8.5
BL1023	11.14	15.8	15.8	—	15.1	14.6	—
BL1034				25.0	10.1	24.5	5.2
BL1046				39.8	15.1	39.3	10.1
BL1223	12.74	19.0	19.0	—	17.7	17.1	—
BL1234				29.3	11.9	28.7	6.1
BL1246				46.7	17.7	46.1	11.9
BL1423	14.32	22.2	22.2	—	20.1	19.4	—
BL1434				33.3	13.5	32.6	6.9
BL1446				53.1	20.1	52.4	13.5
BL1623	17.49	25.4	25.4	—	23.1	22.1	—
BL1634				38.2	15.6	37.2	8.0
BL1646				60.9	23.1	59.9	15.6

Use heat-treated alloy steel (SCM435, etc.) in order to obtain a hardness of HRC40 to 45. For clevises with screws, however, the hardness must be HRC30 to 35 in order to reduce any hazard due to delayed fractures.

Sheaves

Refer to the following chart when manufacturing sheaves.

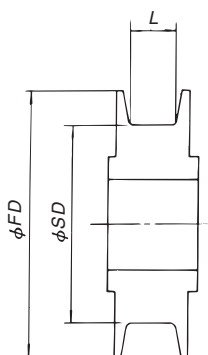

SD = Minimum external sheave diameter = chain pitch x 5
 L = Minimum groove width = pin length x 1.05
 FD = Flange external diameter
 = SD + maximum plate height (H)

AL Type

Chain Pitch	Minimum External Sheave Diameter SD	Flange External Diameter FD	Minimum Groove Width L		
			2 x 2	4 x 4	6 x 6
12.70	63.50	73.90	8.85	15.60	22.40
15.875	79.38	92.38	11.40	20.35	29.20
19.05	95.25	110.85	13.30	23.70	34.10
25.40	127.00	147.80	17.20	31.30	45.40
31.75	158.75	184.75	21.10	38.55	56.00
38.10	190.50	221.70	25.45	46.20	67.05
44.45	222.25	258.65	—	53.90	78.30
50.80	254.00	295.60	—	61.00	88.70

BL Type

Chain Pitch	Minimum External Sheave Diameter SD	Flange External Diameter FD	Minimum Groove Width L		
			2 x 3	3 x 4	4 x 6
12.70	63.50	75.50	13.60	18.10	24.80
15.875	79.38	94.38	15.90	21.15	28.90
19.05	95.25	113.35	20.75	27.80	38.35
25.40	127.00	151.10	25.45	34.20	47.25
31.75	158.75	188.85	30.35	40.80	56.40
38.10	190.50	226.70	35.60	47.80	66.10
44.45	222.25	264.45	40.15	54.00	74.85
50.80	254.00	302.20	45.45	61.35	85.15

- Dimensions for L in the table above assume that only the rivet pin is wound around the sheave. If a connecting pin is wound around the sheave, use $L \geq 2(L_2) \times 1.05$. Design L with an appropriate width while minding the installation precision of the sheave.
- Use sheaves made of machine-structural carbon copper. (S45C, etc.)
- Use heat-treated HRC (35 to 40) for high repetition applications.

Precautions for Use

- Lubricate regularly to prevent pin rotation and improve wear life.**
 Recommended lubrication: ISO VG 100 to 150 (SAE30 to SAE40)
 Lubrication method: With the chain loose, use a brush or oil stick to sufficiently lubricate the outer chain, making sure that oil also penetrates between plates.
 Lubrication period: Lubricate regularly so that sliding sections between pins and inner plates do not dry out.
- Avoid use in corrosive environments.**
 Wipe immediately when there is contact with water and lubricate well. When there is a possibility of corrosion, apply a large amount of grease to the surface of the chain. (To lubricate, wipe off grease and reapply after lubricating between plates.)
- Check for elongation.**
 Replace chain when elongation reaches allowable elongation limit (3%).

Guidelines for checking chain elongation

In order to prevent chain backlash, measure with slight tension on the chain.

Use calipers to measure the distance between the outside L1 and inside L2 of the pins for the portion of the chain articulating around the sheave as shown in the illustration to obtain

$$L = (L_1 + L_2) / 2$$

Obtain chain elongation percentage using the following formula.

$$\text{Chain elongation} = \frac{L - \text{Standard length}}{\text{Standard length}} \times 100(\%)$$

$$\text{Standard length} = \text{Chain pitch} \times \text{No. of links}$$

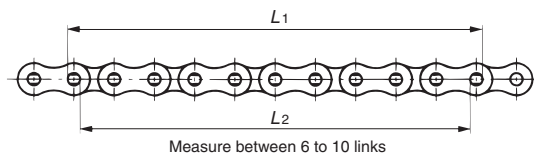

Note: Pitch elongation limit can be quickly checked with a chain elongation scale. For details, see pg. 120.

Ordering

Specify the chain number, number of links, chain end specifications, and link pin requirements.

- The following specifications exist for each end of the chain. Specify your preference.
 - Connecting link
 - End link (Outer and inner end link hole diameters are the same)
 - Outer link
 - Inner link
- If no chain end specification
 With orders for an odd number of links, each end will be given an inner link. With orders for an even number of links, one end will have an inner link and the other a connecting link.
- End pins are available.

Leaf Chains

■ Selection

1. Determine the following based on usage conditions.

- Chain speed
- Number of repetitions per day
- Work load (including inertia and impact strength)
When a chain speed of 30 m/min or 1,000 cycles/day is exceeded, Leaf Chains may be inappropriate due to wear. Use an RS Roller Chain.

2. Determine the type of chain.

- BL Type is recommended.
- Limit use of AL Type to applications with no impact load or wear considerations (under 100 cycles/day).

3. Determine chain size using the following formula.

$$\text{Work load} \times \text{Usage coefficient (Table 1)} \times \text{Safety ratio (Table 2)} \leq \text{Minimum tensile strength}$$

4. ⚠ It is dangerous to use below the safety ratio in Table 2 as it may result in pin rotation and a reduction in strength. In addition, even if the safety ratio in Table 2 is followed, insufficient lubrication may also cause the pins to rotate. Always lubricate the chain regularly.

Table 1 Usage coefficient

Type of impact	Applications	Usage coefficient
Smooth power transmission	Starts and stops are smooth, and load changes are slight (balance weight suspension, etc.)	1.0
Slight impact	Repeated starts and stops, load changes, and reverse operation (forklifts, etc.)	1.3
Impact	Violent starts and stops, load changes, and reverse operation (mining and construction, etc.)	1.5

Table 2 Safety ratio

		Safety ratio	
		2 × 2, 3 × 4 2 × 3, 4 × 4	4 × 6 6 × 6
BL Type	1,000 cycles/day or less	8 or more	9 or more
	10 cycles/day or less	8 or more	9 or more
AL Type	100 cycles/day or less	12 or more	11 or more

5. Where determining a chain's safety ratio is established by law, select a chain with some leeway using that method and this catalog.

RS Sprocket Line-up

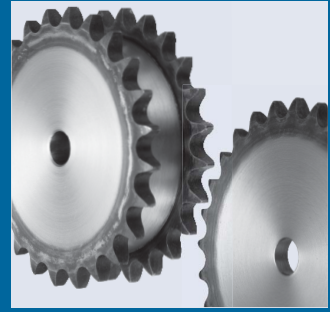

Index

- **RS Sprocket Standard Pilot Bore Series** (1B, 1C, 2B, 2C, and 1A types) — Starting from pg. 18
- **RS Sprocket Standard Pilot Bore Series** (2A type, Single-Dual type) — Pg. 98
- **Fit Bore Series** — Pg. 101
- **Lock Series** (S/N types) — Pg. 108
- **Corrosion Resistant Series** (Stainless Steel, Engineering Plastic, and Fit Bore types) — Pg. 122
- **Specialty Sprockets** — Pg. 133
- **Easy Bore Finishing Service** — Pg. 134
- **RS Sprocket Engineering Information** — Pg. 139

RS Sprocket Types

RS Sprocket types are determined by the following six items.

RS50-1B15T-SS- -

① Size of chain used

② No. of teeth



⑤ Bore type

⑥ Tooth hardening

③ Construction

④ Material

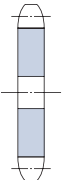
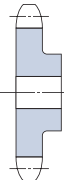
RS Sprockets come in the following four types

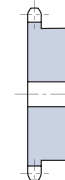

Type	A (Flat)	B (Single Hub)	C (Dual Hub)	SD (Single Dual)
Construction				
Specification	Flat structure with no hub (boss)	Flat structure with a hub (boss) on a single side	Flat structure with hubs (bosses) on both sides	Structure where two single strand chains can be mounted

RS Sprockets come standard in the following materials

Material	Specification	Code
Carbon steel	Standard specifications *Carbon steel for general engineering purposes (General rolled steel used on hubs and other areas)	Blank (no code)
Stainless steel	Corrosion resistant sprocket *Ni-Cr stainless steel	-SS
Plastic	Corrosion resistant, lube-free sprocket *Engineering plastic	-P
Sintered alloy	For RS25 chains *Ferrous sintered alloy	Blank (no code)

⑤ Bore type

RS Sprockets come with the following three types of bores for mounting on shafts.

Visual Appearance	Type	Code
	Pilot Bore sprocket Each sprocket is provided with a pilot bore that needs processing before use.	Blank (no code)
	Fit Bore sprocket Bore diameter is finished to an H7 tolerance, and the keyway tolerance is JIS Js9 tolerance. Includes holes for set screws. Can be used as is without further additional machining.	-H□□J Bore diameter
	Lock sprocket Tightening the bolts will create frictional force on the tapered sleeve that will tightly secure the sprocket to the shaft. No troublesome keyway machining is needed on the shaft side, making it easy to mount and align phases. Removal is also a snap.	Refer to each product page.

⑥ Tooth hardening

Material	Description
Hardened teeth	Use sprockets with hardened teeth when high tooth strength and increased wear life are required. Sprockets with small numbers of teeth and Strong Type RS Sprockets have hardened teeth.
Unhardened teeth	The sprocket teeth have not been hardened. RS Sprockets with large numbers of teeth have unhardened teeth.

List of RS Sprockets

Chain Used	Sprocket Type				
	Construction	Bore	Material	Tooth Hardening	
Drive Chain	Single strand	A Type	Pilot bore	Carbon steel	Hardened or unhardened
		B Type	Pilot bore Fit Bore Series Lock Series	Carbon steel Sintered alloy Stainless steel Engineering plastic	Hardened or unhardened
		C Type	Pilot bore	Carbon steel	Hardened or unhardened
	SD Type		Pilot bore	Carbon steel	Hardened
	Double strand	B Type	Pilot bore	Carbon steel	Hardened or unhardened
		C Type	Pilot bore	Carbon steel	Hardened or unhardened
BS/DIN Roller Chain	Uses a specialty sprocket (made-to-order)		Carbon steel	Hardened or unhardened	
Pin Gear Chain (See the Pin Gear Drive section for more information.)	Uses a specialty sprocket (made-to-order)		Carbon steel	Hardened	
Lambda Chain	Single strand	Can use standard drive sprockets			
	Double strand or greater	Uses a specialty sprocket (made-to-order)			

RS Sprocket 2A Type (Pilot bore or Strong Pilot bore types)

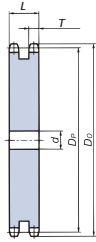

2A Sprocket Teeth and Lateral Width Dimensions

Type	Width L	Tolerance	Tooth Width T	Tolerance
RS40-2A	21.5	-0.052	7.1	-0.036
RS50-2A	26.8	-0.052	8.7	-0.036
RS60-2A	34.5	0.052	11.7	-0.043
RS80-2A	43.9	-0.052	14.6	-0.043
RS100-2A	53.4	-0.074	17.6	-0.043
RS120-2A	68.9	0.074	23.5	-0.052

Hanging hole dimensions
(Bore diameter: RS60/RS80: ϕ 30, RS100, RS120: ϕ 35)

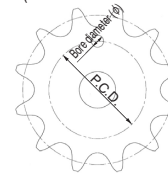

The phase relationship between hanging hole and teeth may differ from the drawing.

●RS40 2A Type

Model Number	Pitch Circle Diameter D_p	(Outer Diameter) (D_o)	Pilot Bore Diameter d	Approximate Mass (kg)	Material
RS40-2A35T	141.68	149	16	2.4	Machine-structural carbon steel, machined.
RS40-2A36T	145.72	153	16	2.5	
RS40-2A38T	153.79	161	16	2.8	
RS40-2A40T	161.87	169	16	3.1	
RS40-2A42T	169.94	177	16	3.5	
RS40-2A45T	182.06	189	18	4.0	
RS40-2A48T	194.18	201	18	4.6	
RS40-2A50T	202.26	209	18	5.0	
RS40-2A54T	218.42	226	18	5.8	
RS40-2A60T	242.66	250	18	7.3	

●RS60 2A Type

Model Number	Pitch Circle Diameter D_p	(Outer Diameter) (D_o)	Pilot Bore Diameter d	Approximate Mass (kg)	Material	Bore Phase (P.C.D.)
RS60-2A23T	139.90	150	18	3.5	Machine-structural carbon steel, machined.	
RS60-2A24T	145.95	156	18	3.8		
RS60-2A25T	151.99	162	18	4.2		
RS60-2A26T	158.04	168	18	4.6		
RS60-2A27T	164.09	174	18	4.9		
RS60-2A28T	170.14	180	18	5.4		
RS60-2A30T	182.25	193	18	6.2		
RS60-2A32T	194.35	205	18	7.1		
RS60-2A34T	206.46	217	18	8.1		
RS60-2A35T	212.52	223	18	8.6		
RS60-2A36T	218.57	229	18	9.1		
RS60-2A38T	230.69	241	18	10.2		
RS60-2A40T	242.80	253	18	11.4		
RS60-2A42T	254.92	266	23	12.6		
RS60-2A45T	273.09	284	23	14.5		
RS60-2A48T	291.27	302	23	16.6		
RS60-2A50T	303.39	314	23	18.1		
RS60-2A54T	327.63	338	23	21.2		
RS60-2A60T	363.99	375	23	26.2		

●RS100 2A Type

Model Number	Pitch Circle Diameter D_p	(Outer Diameter) (D_o)	Pilot Bore Diameter d	Approximate Mass (kg)	Material	Bore Phase (P.C.D.)
RS100-2A15T	152.71	168	28	5.8	Machine-structural carbon steel, machined.	
RS100-2A16T	162.75	179	28	6.8		
RS100-2A17T	172.79	189	28	7.8		
RS100-2A18T	182.84	199	28	8.8		
RS100-2A19T	192.90	209	28	10.0		
RS100-2A20T	202.96	220	28	11.2		
RS100-2A21T	213.03	230	28	12.4		
RS100-2A22T	223.10	240	33	13.7		
RS100-2A23T	233.17	250	33	15.0		
RS100-2A24T	243.25	260	33	16.5		
RS100-2A25T	253.32	270	33	18.1		
RS100-2A26T	263.41	281	33	19.7	Rolloled steel, machined.	
RS100-2A27T	273.49	291	33	21.3		
RS100-2A28T	283.57	301	33	23.0		
RS100-2A30T	303.75	321	33	26.8		
RS100-2A32T	323.92	341	33	30.3		
RS100-2A34T	344.10	362	33	34.5		
RS100-2A35T	354.20	372	33	36.7		
RS100-2A36T	364.29	382	33	38.9		
RS100-2A38T	384.48	402	33	43.7		
RS100-2A40T	404.67	422	33	48.7		
RS100-2A42T	424.86	443	33	53.9		
RS100-2A45T	455.15	473	33	62.4		
RS100-2A48T	485.45	503	33	71.4		
RS100-2A50T	505.65	524	33	77.7		
RS100-2A54T	546.05	564	33	91.2		
RS100-2A60T	606.66	625	33	113.4		

■Ordering Example

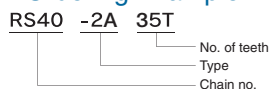

■Strong Type Sprocket Ordering Example

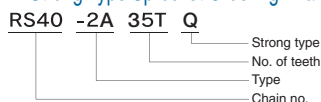

●RS50 2A Type

Model Number	Pitch Circle Diameter D_p	(Outer Diameter) (D_o)	Pilot Bore Diameter d	Approximate Mass (kg)	Material
RS50-2A26T	131.70	140	18	2.4	Machine-structural carbon steel, machined.
RS50-2A27T	136.74	145	18	2.6	
RS50-2A28T	141.79	150	18	2.8	
RS50-2A30T	151.87	161	18	3.3	
RS50-2A32T	161.96	171	18	3.8	
RS50-2A34T	172.05	181	18	4.3	
RS50-2A35T	177.10	186	18	4.6	
RS50-2A36T	182.15	191	18	4.9	
RS50-2A38T	192.24	201	18	5.5	
RS50-2A40T	202.33	211	23	6.0	
RS50-2A42T	212.43	221	23	6.7	
RS50-2A45T	227.58	237	23	7.7	
RS50-2A48T	242.73	252	23	8.9	
RS50-2A50T	252.82	262	23	9.7	
RS50-2A54T	273.03	282	23	11.3	
RS50-2A60T	303.33	312	23	14.1	

●RS80 2A Type

Model Number	Pitch Circle Diameter D_p	(Outer Diameter) (D_o)	Pilot Bore Diameter d	Approximate Mass (kg)	Material	Bore Phase (P.C.D.)
RS80-2A18T	146.27	159	23	4.6	Machine-structural carbon steel, machined.	
RS80-2A19T	154.32	167	23	5.2		
RS80-2A20T	162.37	176	23	5.8		
RS80-2A21T	170.42	184	23	6.5		
RS80-2A22T	178.48	192	28	7.1		
RS80-2A23T	186.54	200	28	7.9		
RS80-2A24T	194.60	208	28	8.6		
RS80-2A25T	202.66	216	28	9.4		
RS80-2A26T	210.72	224	28	10.2		
RS80-2A27T	218.79	233	28	11.1		
RS80-2A28T	226.86	241	28	12.0		
RS80-2A30T	243.00	257	28	14.0	Rolloled steel, machined.	
RS80-2A32T	259.14	273	28	16.0		
RS80-2A34T	275.28	289	28	18.2		
RS80-2A35T	283.36	297	28	19.4		
RS80-2A36T	291.43	306	28	20.6		
RS80-2A38T	307.58	322	28	23.0		
RS80-2A40T	323.74	338	33	25.4		
RS80-2A42T	339.89	354	33	28.1		
RS80-2A45T	364.12	378	33	32.5		
RS80-2A48T	388.36	403	33	37.3		
RS80-2A50T	404.52	419	33	40.6		
RS80-2A54T	436.84	451	33	47.7		
RS80-2A60T	485.33	500	33	59.4		

●RS120 2A Type

Model Number	Pitch Circle Diameter D_p	(Outer Diameter) (D_o)	Pilot Bore Diameter d	Approximate Mass (kg)	Material	Bore Phase (P.C.D.)
RS120-2A14T	171.22	190	28	9.6	Machine-structural carbon steel, machined.	
RS120-2A15T	183.25	202	33	11.1		
RS120-2A16T	195.29	214	33	12.9		
RS120-2A17T	207.35	227	33	14.7		
RS120-2A18T	219.41	239	33	16.7		
RS120-2A19T	231.48	251	33	18.8		
RS120-2A20T	243.55	263	33	21.1		
RS120-2A21T	255.63	276	33	23.5		
RS120-2A22T	267.72	288	33	25.9		
RS120-2A23T	279.80	300	33	28.5		
RS120-2A24T	291.90	312	33	31.3		
RS120-2A25T	303.99	324	33	34.2	Rolloled steel, machined.	
RS120-2A26T	316.09	337	33	37.2		
RS120-2A27T	328.19	349	33	40.3		
RS120-2A28T	340.29	361	33	43.5		
RS120-2A30T	364.49	385	33	49.9		
RS120-2A32T	388.71	410	33	57.2		
RS120-2A34T	412.93	434	33	65.0		
RS120-2A35T	425.04	446	33	69.1		
RS120-2A36T	437.15	458	38	73.2		
RS120-2A38T	461.37	483	38	82.1		
RS120-2A40T	285.60	507	38	91.3		
RS120-2A42T	509.83	531	38	101.2		
RS120-2A45T	546.19	568	38	116.9		
RS120-2A48T	582.54	604	38	133.6		
RS120-2A50T	606.78	628	38	145.5		
RS120-2A54T	655.26	677	38	170.6		
RS120-2A60T	727.99	750	38	212.0		

Note: 1. Maximum bore diameters shown are standard figures. Decide and confirm bore diameters and key surface pressures based on standard machinery design.
2. Sprockets shown with hole positions come with a hanging hole on the sprocket plate. Refer to the diagram above for hanging hole dimensions.
3. Strong Type sprockets, with teeth that can be hardened, are also available. (Made-to-order)

RS40~80 (SD: Single Dual)

RS40 SD Type

Applicable chain pitch : 12.70mm Roller dia : 7.92mm

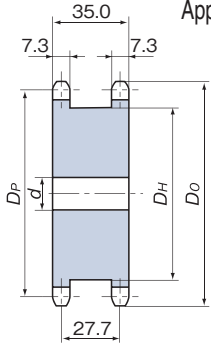

Model numbering example

RS40-SD-□□T

No. of teeth

● RS40 SD Type

All models have hardened teeth.

Model Number	Pitch Circle Dia. D_P	(Outer Dia.) (D_o)	d		Hub		Approximate Mass (kg)
			Pilot Bore	Max.	Diameter D_H	Length L	
RS40-SD-12T	49.07	55	9.5	19	34	35	0.34
RS40-SD-13T	53.07	59	12.7	22	38	35	0.40
RS40-SD-14T	57.07	63	12.7	24	42	35	0.48
RS40-SD-15T	61.08	67	12.7	27	46	35	0.56
RS40-SD-16T	65.10	71	12.7	31	50	35	0.66
RS40-SD-17T	69.12	76	12.7	34	54	35	0.76
RS40-SD-18T	73.14	80	12.7	38	59	35	0.88
RS40-SD-19T	77.16	84	12.7	41	63	35	0.99
RS40-SD-20T	81.18	88	12.7	44	67	35	1.12
RS40-SD-21T	85.21	92	12.7	47	71	35	1.24
RS40-SD-22T	89.24	96	12.7	50	75	35	1.38
RS40-SD-23T	93.27	100	12.7	51	78	35	1.50
RS40-SD-24T	97.30	104	12.7	55	83	35	1.67
RS40-SD-25T	101.33	108	12.7	58	87	35	1.83

Material/Specifications Machine-structural carbon steel, machined.

Contact a Tsubaki representative for teeth numbers not shown above.

RS50 SD Type

Applicable chain pitch : 15.875mm Roller dia : 10.16mm

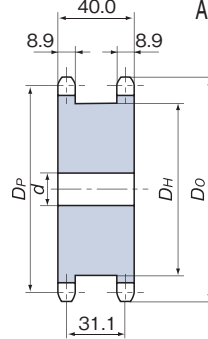

Model numbering example

RS50-SD-□□T

No. of teeth

● RS50 SD Type

All models have hardened teeth.

Model Number	Pitch Circle Dia. D_P	(Outer Dia.) (D_o)	d		Hub		Approximate Mass (kg)
			Pilot Bore	Max.	Diameter D_H	Length L	
RS50-SD-12T	61.34	69	12.7	25	43	40	0.62
RS50-SD-13T	66.33	74	12.7	29	48	40	0.75
RS50-SD-14T	71.34	79	12.7	33	53	40	0.90
RS50-SD-15T	76.35	84	12.7	37	58	40	1.05
RS50-SD-16T	81.37	89	12.7	41	63	40	1.22
RS50-SD-17T	86.39	94	12.7	44	68	40	1.40
RS50-SD-18T	91.42	100	12.7	48	73	40	1.60
RS50-SD-19T	96.45	105	15.9	52	79	40	1.80
RS50-SD-20T	101.48	110	15.9	56	84	40	2.02
RS50-SD-21T	106.51	115	15.9	60	89	40	2.25
RS50-SD-22T	111.55	120	15.9	62	92	40	2.44
RS50-SD-23T	116.59	125	15.9	67	99	40	2.75
RS50-SD-24T	121.62	130	15.9	70	102	40	2.96
RS50-SD-25T	126.66	135	15.9	75	109	40	3.30

Material/Specifications Machine-structural carbon steel, machined.

Contact a Tsubaki representative for teeth numbers not shown above.

RS60 SD Type

Applicable chain pitch : 19.05mm Roller dia : 11.91mm

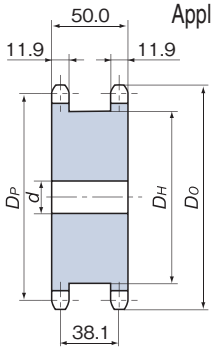

Model numbering example

RS60-SD-□□T

No. of teeth

● RS60 SD Type

All models have hardened teeth.

Model Number	Pitch Circle Dia. D_P	(Outer Dia.) (D_o)	d		Hub		Approximate Mass (kg)
			Pilot Bore	Max.	Diameter D_H	Length L	
RS60-SD-12T	73.60	83	12.7	31	51	50	1.16
RS60-SD-13T	79.60	89	15.9	36	57	50	1.37
RS60-SD-14T	85.61	95	15.9	42	64	50	1.65
RS60-SD-15T	91.63	101	15.9	46	70	50	1.93
RS60-SD-16T	97.65	107	15.9	50	76	50	2.24
RS60-SD-17T	103.67	113	15.9	55	82	50	2.57
RS60-SD-18T	109.70	119	15.9	59	88	50	2.92
RS60-SD-19T	115.74	126	15.9	64	94	50	3.29
RS60-SD-20T	121.78	132	15.9	68	100	50	3.69
RS60-SD-21T	127.82	138	15.9	74	107	50	4.14
RS60-SD-22T	133.86	144	15.9	78	113	50	4.58
RS60-SD-23T	139.90	150	18	82	119	50	5.02
RS60-SD-24T	145.95	156	18	87	125	50	5.51
RS60-SD-25T	151.99	162	18	91	130	50	5.98

Material/Specifications Machine-structural carbon steel, machined.

Contact a Tsubaki representative for teeth numbers not shown above.

RS80 SD Type

Applicable chain pitch : 25.40mm Roller dia : 15.88mm

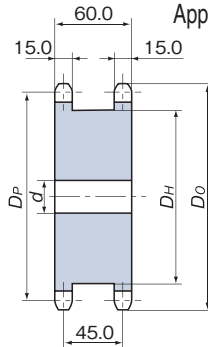

Model numbering example

RS80-SD-□□T

No. of teeth

● RS80 SD Type

All models have hardened teeth.

Model Number	Pitch Circle Dia. D_P	(Outer Dia.) (D_o)	d		Hub		Approximate Mass (kg)
			Pilot Bore	Max.	Diameter D_H	Length L	
RS80-SD-12T	98.14	110	20	45	69	60	2.5
RS80-SD-13T	106.14	118	20	50	77	60	3.0
RS80-SD-14T	114.15	127	20	55	85	60	3.6
RS80-SD-15T	122.17	135	20	63	93	60	4.2
RS80-SD-16T	130.20	143	20	70	102	60	4.9
RS80-SD-17T	138.23	151	20	74	110	60	5.6
RS80-SD-18T	146.27	159	20	80	118	60	6.4

Material/Specifications Machine-structural carbon steel, machined.

Contact a Tsubaki representative for teeth numbers not shown above.

Note: Maximum bore diameters shown are standard figures. Decide and confirm bore diameters and key surface pressures based on standard machinery design.

RS Sprocket Fit Bore (Machined Bore) Series



For RS35 – RS100 Type 1B sprockets.
The bore and keyway have been machined, and comes with two set screws.
Can be used as is with no additional troublesome machining.

Specifications

- Tooth hardening All models feature induction hardened teeth
- Bore Bore diameters in high demand for motors and reducers are available and finished to within H7 tolerances.
- Keyway Finished with a tooth root standard based on Js9 (standard parallel key class) of new JIS B1301-1976 standards.
Contact a Tsubaki representative if precise phase matching is required.
- Set screws All models come with two set screws on the keyway and 90° side, or 120° side if the finished bore diameter exceeds 40mm.

Bore Tolerance

Applicable Bore Diameter	Tolerance (H7)
6 and up to 10	+0.015 0
More than 10 and up to 18	+0.018 0
More than 18 and up to 30	+0.021 0
More than 30 and up to 50	+0.025 0
More than 50 and up to 65	+0.030 0

Keyway Dimensions and Set Screw Size

Applicable Bore Dia.	Keyway Width	Tolerance (Js9)	Keyway Depth	Tolerance	Set Screw Size
10 and up to 12	4	±0.0150	1.8	+0.1 0	M4
More than 12 and up to 17	5		2.3		M5
More than 17 and up to 22	6		2.8		M6
More than 22 and up to 30	8	±0.0180	3.3	+0.2 0	M8
More than 30 and up to 38	10				
More than 38 and up to 44	12	±0.0215	3.8		M10
More than 44 and up to 50	14		4.3		
More than 50 and up to 58	16		4.4		
More than 58 and up to 65	18				

Precautions

1. When using the set screws, be sure to tighten the set screws securely so that they will not loosen. Remove the set screws if they are not required.
2. Take appropriate measures, such as the use of a stopper plate, to prevent the sprocket from falling off the shaft.

RS Sprocket Fit Bore Ordering Guide

Include the product code and model number in your order.

Ordering Example

Product Code	Model Number	Quantity
G120381	RS40-1B20T-H15J	10

Model Numbering Example

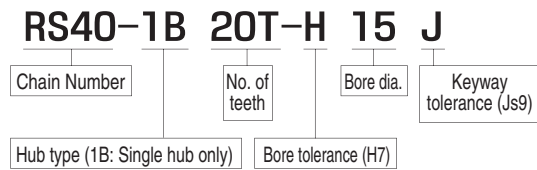

Other bore processing information

Tsubaki offers the following additional finishing for sprocket bores besides our Fit Bore Series (bore finished within H7 tolerances, keyway finished based on Js9 standards).

Use Tsubaki's **Easy Bore Finishing service (pg. 134)** if there is no Fit Bore Series for your desired sprocket.

Contact a Tsubaki representative regarding special bore finishing.

RS35 Fit Bore®

RS35 Fit Bore

Applicable chain pitch : 9.525mm Roller dia : 5.08mm

Hub with groove (9T – 13T)

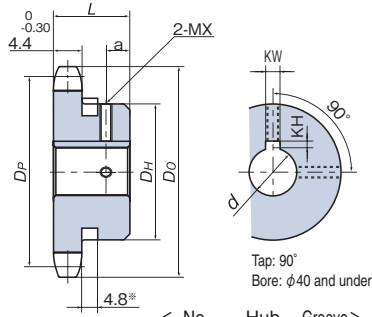

Hub without groove (14T and over)

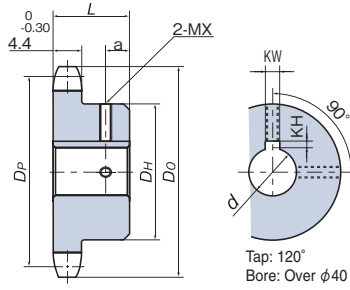

No. of teeth:	Hub dia :	Groove dia :
9T	: φ 22	: φ 16
10T	: φ 25	: φ 18
11T	: φ 27	: φ 22
12T	: φ 31	: φ 24
13T	: φ 32	: φ 28

Applicable Bore Dia.	Keyway Width	Tolerance (Js9)	Keyway Depth	Tolerance	Set Screw Size
10 and up to 12	4		1.8		M4
More than 12 and up to 17	5	±0.0150	2.3	+0.1 0	M5
More than 17 and up to 22	6		2.8		M6
More than 22 and up to 30	8	±0.0180	3.3		M8
More than 30 and up to 38	10		3.8	+0.2 0	M8
More than 38 and up to 44	12		4.3		M10
More than 44 and up to 50	14	±0.0215	4.4		M10
More than 50 and up to 58	16				
More than 58 and up to 65	18				

* Comes with two alloy steel set screws.

Model Numbering Example RS35-1B 20T – H 15 J

- Keyway tolerance (Js9)
- Bore dia.
- Bore tolerance (H7)
- No. of teeth
- Type
- Chain number

*The groove is provided on the perimeter of the hub to prevent interference with the chain.

Model Number	No. of Teeth	Pitch Circle Dia. DP	(Outer Dia.) (DO)	Hub Dia. DH	Hub Length L	Tap Position a	Finished Bore Dia. d										No. of Teeth	
							10	12	14	15	16	17	18	19	20	22		
RS35-1B 9T-H□□J	9	27.85	32	22	20	5	○											9
RS35-1B 10T-H□□J	10	30.82	35	25	20	5	○	○										10
RS35-1B 11T-H□□J	11	33.81	38	27	20	5	○	○	○									11
RS35-1B 12T-H□□J	12	36.80	41	31	20	5	○	○	○	○								12
RS35-1B 13T-H□□J	13	39.80	44	32	20	5	○	○	○	○	○							13
RS35-1B 14T-H□□J	14	42.81	47	30	20	8	○	○	○	○	○	○						14
RS35-1B 15T-H□□J	15	45.81	51	35	20	8	○	○	○	○	○	○	○					15
RS35-1B 16T-H□□J	16	48.82	54	37	20	8	○	○	○	○	○	○	○	○				16
RS35-1B 17T-H□□J	17	51.84	57	41	20	8	○	○	○	○	○	○	○	○	○		○	17
RS35-1B 18T-H□□J	18	54.85	60	44	20	8	○	○	○	○	○	○	○	○	○	○	○	18
RS35-1B 19T-H□□J	19	57.87	63	47	20	8	○	○	○	○	○	○	○	○	○	○	○	19
RS35-1B 20T-H□□J	20	60.89	66	50	20	8	○	○	○	○	○	○	○	○	○	○	○	20
RS35-1B 21T-H□□J	21	63.91	69	53	20	8	○	○	○	○	○	○	○	○	○	○	○	21
RS35-1B 22T-H□□J	22	66.93	72	53	20	8	○	○	○	○	○	○	○	○	○	○	○	22
RS35-1B 23T-H□□J	23	69.95	75	53	20	8	○	○	○	○	○	○	○	○	○	○	○	23
RS35-1B 24T-H□□J	24	72.97	78	53	22	10	○	○	○	○	○	○	○	○	○	○	○	24
RS35-1B 25T-H□□J	25	76.00	81	53	22	10	○	○	○	○	○	○	○	○	○	○	○	25
RS35-1B 26T-H□□J	26	79.02	84	53	22	10	○	○	○	○	○	○	○	○	○	○	○	26
RS35-1B 27T-H□□J	27	82.05	87	53	22	10	○	○	○	○	○	○	○	○	○	○	○	27
RS35-1B 28T-H□□J	28	85.07	90	53	22	10	○	○	○	○	○	○	○	○	○	○	○	28
RS35-1B 30T-H□□J	30	91.12	96	53	22	10	○	○	○	○	○	○	○	○	○	○	○	30
RS35-1B 32T-H□□J	32	97.18	102	53	22	10	○	○	○	○	○	○	○	○	○	○	○	32
RS35-1B 34T-H□□J	34	103.23	109	53	22	10	○	○	○	○	○	○	○	○	○	○	○	34
RS35-1B 35T-H□□J	35	106.26	112	53	22	10	○	○	○	○	○	○	○	○	○	○	○	35
RS35-1B 36T-H□□J	36	109.29	115	53	22	10	○	○	○	○	○	○	○	○	○	○	○	36
RS35-1B 38T-H□□J	38	115.34	121	63	25	10	○	○	○	○	○	○	○	○	○	○	○	38
RS35-1B 40T-H□□J	40	121.40	127	63	25	10	○	○	○	○	○	○	○	○	○	○	○	40

Model Number	No. of Teeth	Pitch Circle Dia. DP	(Outer Dia.) (DO)	Hub Dia. DH	Hub Length L	Tap Position a	Finished Bore Dia. d							No. of Teeth				
							24	25	28	30	32	35	38					
RS35-1B 17T-H□□J	17	51.84	57	41	20	8	○										17	
RS35-1B 18T-H□□J	18	54.85	60	44	20	8	○											18
RS35-1B 19T-H□□J	19	57.87	63	47	20	8	○	○		○								19
RS35-1B 20T-H□□J	20	60.89	66	50	20	8	○	○	○		○							20
RS35-1B 21T-H□□J	21	63.91	69	53	20	8	○	○	○	○		○						21
RS35-1B 22T-H□□J	22	66.93	72	53	20	8	○	○	○	○	○		○					22
RS35-1B 23T-H□□J	23	69.95	75	53	20	8	○	○	○	○	○	○		○				23
RS35-1B 24T-H□□J	24	72.97	78	53	22	7	○	○	○	○	○	○	○		○			24
RS35-1B 25T-H□□J	25	76.00	81	53	22	7	○	○	○	○	○	○	○	○		○		25
RS35-1B 26T-H□□J	26	79.02	84	53	22	7	○	○	○	○	○	○	○	○		○		26
RS35-1B 27T-H□□J	27	82.05	87	53	22	7	○	○	○	○	○	○	○	○	○		○	27
RS35-1B 28T-H□□J	28	85.07	90	53	22	7	○	○	○	○	○	○	○	○	○		○	28
RS35-1B 30T-H□□J	30	91.12	96	53	22	7	○	○	○	○	○	○	○	○	○		○	30
RS35-1B 32T-H□□J	32	97.18	102	53	22	7	○	○	○	○	○	○	○	○	○		○	32
RS35-1B 34T-H□□J	34	103.23	109	53	22	7	○	○	○	○	○	○	○	○	○		○	34
RS35-1B 35T-H□□J	35	106.26	112	53	22	7	○	○	○	○	○	○	○	○	○		○	35
RS35-1B 36T-H□□J	36	109.29	115	53	22	7	○	○	○	○	○	○	○	○	○		○	36
RS35-1B 38T-H□□J	38	115.34	121	63	25	10	○	○	○	○	○	○	○	○	○	○	○	38
RS35-1B 40T-H□□J	40	121.40	127	63	25	10	○	○	○	○	○	○	○	○	○	○	○	40

Enter the bore diameter for the □ found in the model numbers.

Before Use
 Standard Roller Chains
 Lubrication
 Heavy Duty Roller Chains
 Corrosion Resistant Roller Chains
 Specialty Roller Chains
 Sprockets
 Pin Gear Drives
 Accessories
 Selection
 Handling

RS40 Fit Bore®

RS40 Fit Bore

Applicable chain pitch : 12.70mm Roller dia : 7.92mm

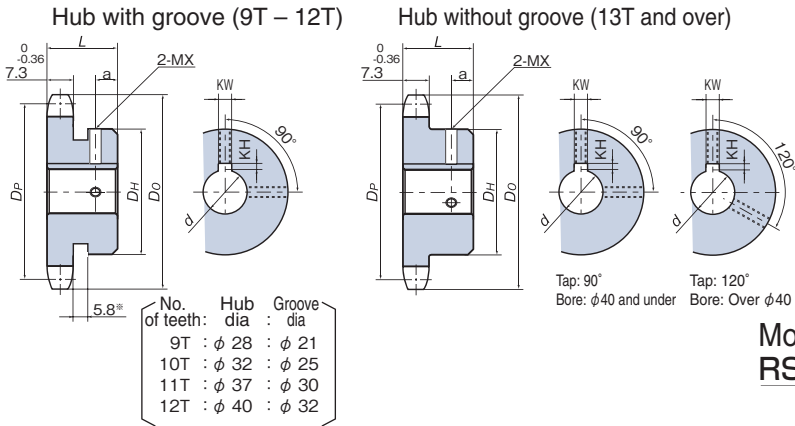

Applicable Bore Dia.	Keyway Width	Tolerance (Js9)	Keyway Depth	Tolerance	Set Screw Size
10 and up to 12	4		1.8		M4
More than 12 and up to 17	5	±0.0150	2.3	+0.1 0	M5
More than 17 and up to 22	6		2.8		M6
More than 22 and up to 30	8	±0.0180	3.3	+0.2 0	M8
More than 30 and up to 38	10				
More than 38 and up to 44	12	±0.0215	3.8		M10
More than 44 and up to 50	14		4.3		
More than 50 and up to 58	16		4.4		
More than 58 and up to 65	18				

• Comes with two alloy steel set screws.

Model Numbering Example RS40-1B 20T - H 15 J

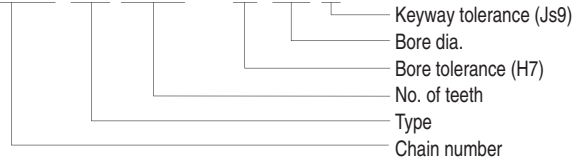

*The groove is provided on the perimeter of the hub to prevent interference with the chain.

Model Number	No. of Teeth	Pitch Circle Dia. D_P	(Outer Dia.) (D_o)	Hub Dia. D_H	Hub Length L	Tap Position a	Finished Bore Dia. d										No. of Teeth	
							10	12	14	15	16	17	18	19	20	22		
RS40-1B 9T-H□□J	9	37.13	43	28	22	5	○	○	○	○	○	○	○	○	○	○	○	9
RS40-1B10T-H□□J	10	41.10	47	32	22	5	○	○	○	○	○	○	○	○	○	○	○	10
RS40-1B11T-H□□J	11	45.08	51	37	22	5	○	○	○	○	○	○	○	○	○	○	○	11
RS40-1B12T-H□□J	12	49.07	55	40	22	5	○	○	○	○	○	○	○	○	○	○	○	12
RS40-1B13T-H□□J	13	53.07	59	37	22	7	○	○	○	○	○	○	○	○	○	○	○	13
RS40-1B14T-H□□J	14	57.07	63	42	22	7	○	○	○	○	○	○	○	○	○	○	○	14
RS40-1B15T-H□□J	15	61.08	67	46	22	7	○	○	○	○	○	○	○	○	○	○	○	15
RS40-1B16T-H□□J	16	65.10	71	50	22	7	○	○	○	○	○	○	○	○	○	○	○	16
RS40-1B17T-H□□J	17	69.12	76	54	22	7	○	○	○	○	○	○	○	○	○	○	○	17
RS40-1B18T-H□□J	18	73.14	80	57	22	7	○	○	○	○	○	○	○	○	○	○	○	18
RS40-1B19T-H□□J	19	77.16	84	62	22	7	○	○	○	○	○	○	○	○	○	○	○	19
RS40-1B20T-H□□J	20	81.18	88	67	25	7	○	○	○	○	○	○	○	○	○	○	○	20
RS40-1B21T-H□□J	21	85.21	92	71	25	7	○	○	○	○	○	○	○	○	○	○	○	21
RS40-1B22T-H□□J	22	89.24	96	75	25	7	○	○	○	○	○	○	○	○	○	○	○	22
RS40-1B23T-H□□J	23	93.27	100	77	25	7	○	○	○	○	○	○	○	○	○	○	○	23
RS40-1B24T-H□□J	24	97.30	104	63	25	7	○	○	○	○	○	○	○	○	○	○	○	24
RS40-1B25T-H□□J	25	101.33	108	63	25	7	○	○	○	○	○	○	○	○	○	○	○	25
RS40-1B26T-H□□J	26	105.36	112	63	25	7	○	○	○	○	○	○	○	○	○	○	○	26
RS40-1B27T-H□□J	27	109.40	116	63	25	7	○	○	○	○	○	○	○	○	○	○	○	27
RS40-1B28T-H□□J	28	113.43	120	63	25	7	○	○	○	○	○	○	○	○	○	○	○	28
RS40-1B30T-H□□J	30	121.50	128	63	25	7	○	○	○	○	○	○	○	○	○	○	○	30
RS40-1B32T-H□□J	32	129.57	137	68	28	8	○	○	○	○	○	○	○	○	○	○	○	32
RS40-1B34T-H□□J	34	137.64	145	68	28	8	○	○	○	○	○	○	○	○	○	○	○	34
RS40-1B35T-H□□J	35	141.68	149	68	28	8	○	○	○	○	○	○	○	○	○	○	○	35
RS40-1B36T-H□□J	36	145.72	153	68	28	8	○	○	○	○	○	○	○	○	○	○	○	36

Model Number	No. of Teeth	Pitch Circle Dia. D_P	(Outer Dia.) (D_o)	Hub Dia. D_H	Hub Length L	Tap Position a	Finished Bore Dia. d							No. of Teeth				
							24	25	28	30	32	35	38		40	42	45	
RS40-1B14T-H□□J	14	57.07	63	42	22	7	○	○	○	○	○	○	○	○	○	○	○	14
RS40-1B15T-H□□J	15	61.08	67	46	22	7	○	○	○	○	○	○	○	○	○	○	○	15
RS40-1B16T-H□□J	16	65.10	71	50	22	7	○	○	○	○	○	○	○	○	○	○	○	16
RS40-1B17T-H□□J	17	69.12	76	54	22	7	○	○	○	○	○	○	○	○	○	○	○	17
RS40-1B18T-H□□J	18	73.14	80	57	22	7	○	○	○	○	○	○	○	○	○	○	○	18
RS40-1B19T-H□□J	19	77.16	84	62	22	7	○	○	○	○	○	○	○	○	○	○	○	19
RS40-1B20T-H□□J	20	81.18	88	67	25	7	○	○	○	○	○	○	○	○	○	○	○	20
RS40-1B21T-H□□J	21	85.21	92	71	25	7	○	○	○	○	○	○	○	○	○	○	○	21
RS40-1B22T-H□□J	22	89.24	96	75	25	7	○	○	○	○	○	○	○	○	○	○	○	22
RS40-1B23T-H□□J	23	93.27	100	77	25	7	○	○	○	○	○	○	○	○	○	○	○	23
RS40-1B24T-H□□J	24	97.30	104	63	25	7	○	○	○	○	○	○	○	○	○	○	○	24
RS40-1B25T-H□□J	25	101.33	108	63	25	7	○	○	○	○	○	○	○	○	○	○	○	25
RS40-1B26T-H□□J	26	105.36	112	63	25	7	○	○	○	○	○	○	○	○	○	○	○	26
RS40-1B27T-H□□J	27	109.40	116	63	25	7	○	○	○	○	○	○	○	○	○	○	○	27
RS40-1B28T-H□□J	28	113.43	120	63	25	7	○	○	○	○	○	○	○	○	○	○	○	28
RS40-1B30T-H□□J	30	121.50	128	63	25	7	○	○	○	○	○	○	○	○	○	○	○	30
RS40-1B32T-H□□J	32	129.57	137	68	28	8	○	○	○	○	○	○	○	○	○	○	○	32
RS40-1B34T-H□□J	34	137.64	145	68	28	8	○	○	○	○	○	○	○	○	○	○	○	34
RS40-1B35T-H□□J	35	141.68	149	68	28	8	○	○	○	○	○	○	○	○	○	○	○	35
RS40-1B36T-H□□J	36	145.72	153	68	28	8	○	○	○	○	○	○	○	○	○	○	○	36
RS40-1B38T-H□□J	38	153.79	161	68	28	8	○	○	○	○	○	○	○	○	○	○	○	38
RS40-1B40T-H□□J	40	161.87	169	68	28	8	○	○	○	○	○	○	○	○	○	○	○	40

Enter the bore diameter for the □ found in the model numbers.

RS50 Fit Bore®

RS50 Fit Bore

Applicable chain pitch : 15.875mm Roller dia : 10.16mm

Hub with groove (9T – 13T)

Hub without groove (14T and over)

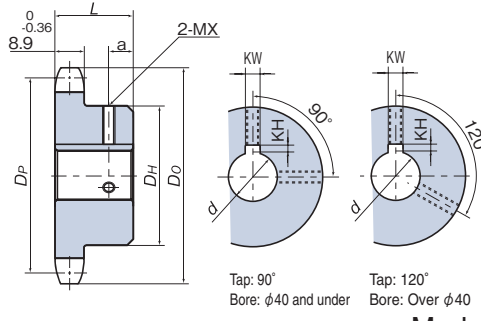
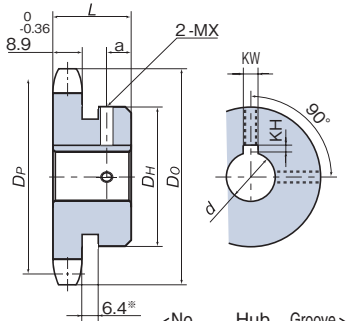

No. of teeth	Hub dia	Groove dia
9T	φ 34	φ 27
10T	φ 40	φ 32
11T	φ 46	φ 37
12T	φ 51	φ 42
13T	φ 51	φ 47

Applicable Bore Dia.	Keyway Width	Tolerance (Js9)	Keyway Depth	Tolerance	Set Screw Size
10 and up to 12	4		1.8		M4
More than 12 and up to 17	5	±0.0150	2.3	+0.1 0	M5
More than 17 and up to 22	6		2.8		M6
More than 22 and up to 30	8				
More than 30 and up to 38	10	±0.0180	3.3		M8
More than 38 and up to 44	12				
More than 44 and up to 50	14		3.8	+0.2 0	
More than 50 and up to 58	16	±0.0215	4.3		M10
More than 58 and up to 65	18		4.4		

• Comes with two alloy steel set screws.

Model Numbering Example RS50-1B 20T – H 15 J

- Keyway tolerance (Js9)
- Bore dia.
- Bore tolerance (H7)
- No. of teeth
- Type
- Chain number

*The groove is provided on the perimeter of the hub to prevent interference with the chain.

Model Number	No. of Teeth	Pitch Circle Dia. DP	Outer Dia. (DO)	Hub Dia. DH	Hub Length L	Tap Position a	Finished Bore Dia. d								No. of Teeth		
							14	15	16	17	18	19	20	22		24	
RS50-1B 9T-H□□J	9	46.42	53	34	25	6											9
RS50-1B 10T-H□□J	10	51.37	58	40	25	6											10
RS50-1B 11T-H□□J	11	56.35	64	46	25	6											11
RS50-1B 12T-H□□J	12	61.34	69	51	25	6											12
RS50-1B 13T-H□□J	13	66.33	74	51	25	6											13
RS50-1B 14T-H□□J	14	71.34	79	52	25	7											14
RS50-1B 15T-H□□J	15	76.35	84	57	25	7											15
RS50-1B 16T-H□□J	16	81.37	89	62	25	7											16
RS50-1B 17T-H□□J	17	86.39	94	67	25	7											17
RS50-1B 18T-H□□J	18	91.42	100	72	28	8											18
RS50-1B 19T-H□□J	19	96.45	105	73	28	8											19
RS50-1B 20T-H□□J	20	101.48	110	73	28	8											20
RS50-1B 21T-H□□J	21	106.51	115	73	28	8											21
RS50-1B 22T-H□□J	22	111.55	120	73	28	8											22
RS50-1B 23T-H□□J	23	116.59	125	73	28	8											23
RS50-1B 24T-H□□J	24	121.62	130	73	28	8											24
RS50-1B 25T-H□□J	25	126.66	135	73	28	8											25
Model Number	No. of Teeth	Pitch Circle Dia. DP	Outer Dia. (DO)	Hub Dia. DH	Hub Length L	Tap Position a	Finished Bore Dia. d								No. of Teeth		
							25	28	30	32	35	38	40	42		45	
RS50-1B 11T-H□□J	11	56.35	64	46	25	6											11
RS50-1B 12T-H□□J	12	61.34	69	51	25	6											12
RS50-1B 13T-H□□J	13	66.33	74	51	25	6											13
RS50-1B 14T-H□□J	14	71.34	79	52	25	7											14
RS50-1B 15T-H□□J	15	76.35	84	57	25	7											15
RS50-1B 16T-H□□J	16	81.37	89	62	25	7											16
RS50-1B 17T-H□□J	17	86.39	94	67	25	7											17
RS50-1B 18T-H□□J	18	91.42	100	72	28	8											18
RS50-1B 19T-H□□J	19	96.45	105	73	28	8											19
RS50-1B 20T-H□□J	20	101.48	110	73	28	8											20
RS50-1B 21T-H□□J	21	106.51	115	73	28	8											21
RS50-1B 22T-H□□J	22	111.55	120	73	28	8											22
RS50-1B 23T-H□□J	23	116.59	125	73	28	8											23
RS50-1B 24T-H□□J	24	121.62	130	73	28	8											24
RS50-1B 25T-H□□J	25	126.66	135	73	28	8											25
RS50-1B 26T-H□□J	26	131.70	140	73	28	8											26
RS50-1B 27T-H□□J	27	136.74	145	73	28	8											27
RS50-1B 28T-H□□J	28	141.79	150	73	28	8											28
RS50-1B 30T-H□□J	30	151.87	161	73	28	8											30
RS50-1B 32T-H□□J	32	161.96	171	73	28	8											32
RS50-1B 34T-H□□J	34	172.05	181	73	28	8											34
RS50-1B 35T-H□□J	35	177.10	186	73	28	8											35

Enter the bore diameter for the □ found in the model numbers.

Before Use | Standard Roller Chains | Lube-Free Roller Chains | Heavy Duty Roller Chains | Corrosion Resistant Roller Chains | Specialty Roller Chains | Sprockets | Pin Gear Drives | Accessories | Selection | Handling

RS60 Fit Bore®

RS60 Fit Bore

Applicable chain pitch : 19.05mm Roller dia : 11.91mm

Hub with groove (9T – 11T)

Hub without groove (12T and over)

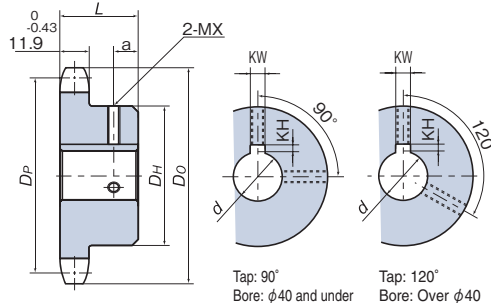
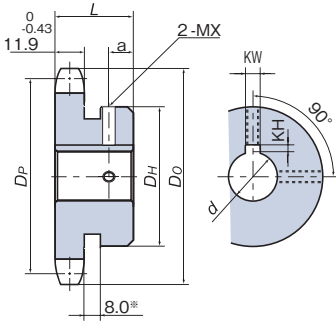

No. of teeth:	Hub dia :	Groove dia :
9T	: phi 43	: phi 32
10T	: phi 49	: phi 37
11T	: phi 51	: phi 45

*The groove is provided on the perimeter of the hub to prevent interference with the chain.

Applicable Bore Dia.	Keyway Width	Tolerance (Js9)	Keyway Depth	Tolerance	Set Screw Size
10 and up to 12	4		1.8		M4
More than 12 and up to 17	5	±0.0150	2.3	+0.1 0	M5
More than 17 and up to 22	6		2.8		M6
More than 22 and up to 30	8	±0.0180	3.3		M8
More than 30 and up to 38	10		3.8	+0.2 0	M8
More than 38 and up to 44	12		4.3		M10
More than 44 and up to 50	14	±0.0215	4.4		M10
More than 50 and up to 58	16				M10
More than 58 and up to 65	18				M10

• Comes with two alloy steel set screws.

Model Numbering Example RS60-1B 20T – H 19 J

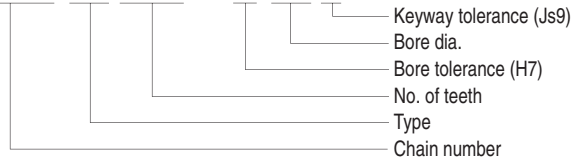

Model Number	No. of Teeth	Pitch Circle Dia. D_P	(Outer Dia.) (D_o)	Hub Dia. D_H	Hub Length L	Tap Position a	Finished Bore Dia. d								No. of Teeth	
							19	20	22	24	25	28	30	32		
RS60-1B 9T-H□□J	9	55.70	64	43	32	6		○	○	○	○	○	○	○	○	9
RS60-1B10T-H□□J	10	61.65	70	49	32	6	○	○	○	○	○	○	○	○	○	10
RS60-1B11T-H□□J	11	67.62	76	51	32	6	○	○	○	○	○	○	○	○	○	11
RS60-1B12T-H□□J	12	73.60	83	51	32	12	○	○	○	○	○	○	○	○	○	12
RS60-1B13T-H□□J	13	79.60	89	57	32	12	○	○	○	○	○	○	○	○	○	13
RS60-1B14T-H□□J	14	85.61	95	62	32	12	○	○	○	○	○	○	○	○	○	14
RS60-1B15T-H□□J	15	91.63	101	68	32	12	○	○	○	○	○	○	○	○	○	15
RS60-1B16T-H□□J	16	97.65	107	73	32	12	○	○	○	○	○	○	○	○	○	16
RS60-1B17T-H□□J	17	103.67	113	73	32	12	○	○	○	○	○	○	○	○	○	17
RS60-1B18T-H□□J	18	109.70	119	83	40	12	○	○	○	○	○	○	○	○	○	18
RS60-1B19T-H□□J	19	115.74	126	83	40	12	○	○	○	○	○	○	○	○	○	19
RS60-1B20T-H□□J	20	121.78	132	83	40	12	○	○	○	○	○	○	○	○	○	20
RS60-1B21T-H□□J	21	127.82	138	83	40	12		○	○	○	○	○	○	○	○	21
RS60-1B22T-H□□J	22	133.86	144	83	40	12		○	○	○	○	○	○	○	○	22
RS60-1B23T-H□□J	23	139.90	150	83	40	12		○	○	○	○	○	○	○	○	23
RS60-1B24T-H□□J	24	145.95	156	83	40	12		○	○	○	○	○	○	○	○	24
RS60-1B25T-H□□J	25	151.99	162	83	40	12		○	○	○	○	○	○	○	○	25
RS60-1B26T-H□□J	26	158.04	168	83	40	12		○	○	○	○	○	○	○	○	26
RS60-1B27T-H□□J	27	164.09	174	83	40	12		○	○	○	○	○	○	○	○	27
RS60-1B28T-H□□J	28	170.14	180	83	40	12		○	○	○	○	○	○	○	○	28
RS60-1B30T-H□□J	30	182.25	193	83	40	12		○	○	○	○	○	○	○	○	30

Model Number	No. of Teeth	Pitch Circle Dia. D_P	(Outer Dia.) (D_o)	Hub Dia. D_H	Hub Length L	Tap Position a	Finished Bore Dia. d								No. of Teeth	
							35	38	40	42	45	48	50	55		
RS60-1B13T-H□□J	13	79.60	89	57	32	12	○									13
RS60-1B14T-H□□J	14	85.61	95	62	32	12	○	○								14
RS60-1B15T-H□□J	15	91.63	101	68	32	12	○	○	○							15
RS60-1B16T-H□□J	16	97.65	107	73	32	12	○	○	○	○						16
RS60-1B17T-H□□J	17	103.67	113	73	32	12	○	○	○	○	○					17
RS60-1B18T-H□□J	18	109.70	119	83	40	12	○	○	○	○	○	○				18
RS60-1B19T-H□□J	19	115.74	126	83	40	12	○	○	○	○	○	○	○			19
RS60-1B20T-H□□J	20	121.78	132	83	40	12	○	○	○	○	○	○	○	○		20
RS60-1B21T-H□□J	21	127.82	138	83	40	12	○	○	○	○	○	○	○	○	○	21
RS60-1B22T-H□□J	22	133.86	144	83	40	12	○	○	○	○	○	○	○	○	○	22
RS60-1B23T-H□□J	23	139.90	150	83	40	12	○	○	○	○	○	○	○	○	○	23
RS60-1B24T-H□□J	24	145.95	156	83	40	12	○	○	○	○	○	○	○	○	○	24
RS60-1B25T-H□□J	25	151.99	162	83	40	12	○	○	○	○	○	○	○	○	○	25
RS60-1B26T-H□□J	26	158.04	168	83	40	12	○	○	○	○	○	○	○	○	○	26
RS60-1B27T-H□□J	27	164.09	174	83	40	12	○	○	○	○	○	○	○	○	○	27
RS60-1B28T-H□□J	28	170.14	180	83	40	12	○	○	○	○	○	○	○	○	○	28
RS60-1B30T-H□□J	30	182.25	193	83	40	12	○	○	○	○	○	○	○	○	○	30

Enter the bore diameter for the □ found in the model numbers.

Before Use | Standard Roller Chains | Lubrication | Heavy Duty Roller Chains | Corrosion Resistant Roller Chains | Specialty Roller Chains | Sprockets | Pin Gear Drives | Accessories | Selection | Handling

RS80 Fit Bore®

RS80 Fit Bore

Applicable chain pitch : 25.40mm Roller dia : 15.88mm

Hub with groove (9T)

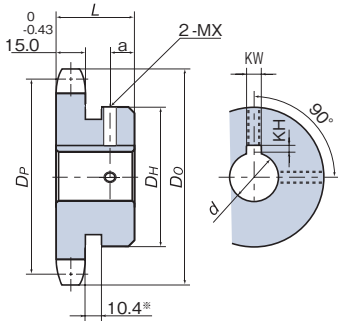

Hub without groove (10T and over)

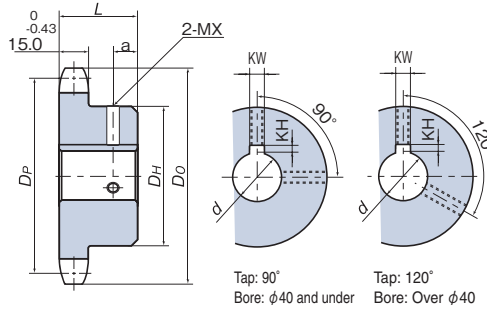

Applicable Bore Dia.	Keyway Width	Tolerance (Js9)	Keyway Depth	Tolerance	Set Screw Size
10 and up to 12	4	±0.0150	1.8	+0.1 0	M4
More than 12 and up to 17	5		2.3		M5
More than 17 and up to 22	6		2.8		M6
More than 22 and up to 30	8	±0.0180	3.3	+0.2 0	M8
More than 30 and up to 38	10				
More than 38 and up to 44	12	±0.0215	3.8		
More than 44 and up to 50	14		4.3		
More than 50 and up to 58	16		4.4		
More than 58 and up to 65	18			M10	

• Comes with two alloy steel set screws.

No. of teeth : 9T
Hub dia : φ 58
Groove dia : φ 44

*The groove is provided on the perimeter of the hub to prevent interference with the chain.

Model Numbering Example

RS80-1B 20T – H 25 J

Keyway tolerance (Js9)
Bore dia.
Bore tolerance (H7)
No. of teeth
Type
Chain number

Model Number	No. of Teeth	Pitch Circle Dia. D_P	(Outer Dia.) (D_o)	Hub Dia. D_H	Hub Length L	Tap Position a	Finished Bore Dia. d						No. of Teeth
							25	28	30	32	35	38	
RS80-1B 9T-H□□J	9	74.26	85	58	40	8	○	○	○	○	○	○	9
RS80-1B 10T-H□□J	10	82.20	93	52	40	12	○	○	○	○	○	○	10
RS80-1B 11T-H□□J	11	90.16	102	60	40	12	○	○	○	○	○	○	11
RS80-1B 12T-H□□J	12	98.14	110	67	40	12	○	○	○	○	○	○	12
RS80-1B 13T-H□□J	13	106.14	118	77	40	12	○	○	○	○	○	○	13
RS80-1B 14T-H□□J	14	114.15	127	77	40	12	○	○	○	○	○	○	14
RS80-1B 15T-H□□J	15	122.17	135	93	40	12	○	○	○	○	○	○	15
RS80-1B 16T-H□□J	16	130.20	143	93	40	12	○	○	○	○	○	○	16
RS80-1B 17T-H□□J	17	138.23	151	93	40	12	○	○	○	○	○	○	17
RS80-1B 18T-H□□J	18	146.27	159	93	40	12	○	○	○	○	○	○	18
RS80-1B 19T-H□□J	19	154.32	167	93	40	12	○	○	○	○	○	○	19
RS80-1B 20T-H□□J	20	162.37	176	93	40	12	○	○	○	○	○	○	20
RS80-1B 21T-H□□J	21	170.42	184	93	40	12	○	○	○	○	○	○	21

Model Number	No. of Teeth	Pitch Circle Dia. D_P	(Outer Dia.) (D_o)	Hub Dia. D_H	Hub Length L	Tap Position a	Finished Bore Dia. d						No. of Teeth
							40	42	45	48	50	55	
RS80-1B 12T-H□□J	12	98.14	110		40	12	○	○	○	○	○	○	12
RS80-1B 13T-H□□J	13	106.14	118		40	12	○	○	○	○	○	○	13
RS80-1B 14T-H□□J	14	114.15	127		40	12	○	○	○	○	○	○	14
RS80-1B 15T-H□□J	15	122.17	135		40	12	○	○	○	○	○	○	15
RS80-1B 16T-H□□J	16	130.20	143		40	12	○	○	○	○	○	○	16
RS80-1B 17T-H□□J	17	138.23	151		40	12	○	○	○	○	○	○	17
RS80-1B 18T-H□□J	18	146.27	159		40	12	○	○	○	○	○	○	18
RS80-1B 19T-H□□J	19	154.32	167		40	12	○	○	○	○	○	○	19
RS80-1B 20T-H□□J	20	162.37	176		40	12	○	○	○	○	○	○	20
RS80-1B 21T-H□□J	21	170.42	184		40	12	○	○	○	○	○	○	21

Enter the bore diameter for the □ found in the model numbers.

RS100 Fit Bore®

Applicable chain pitch : 31.75mm Roller dia : 19.05mm

RS100 Fit Bore

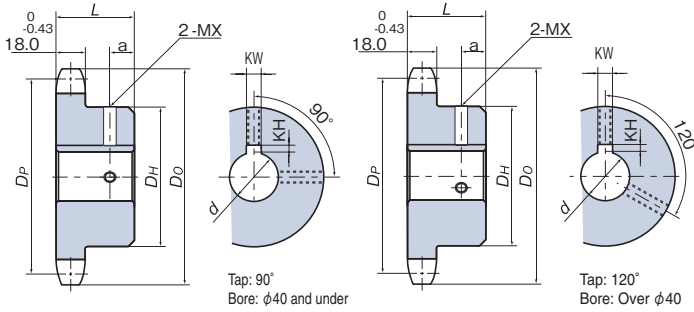

Applicable Bore Dia.	Keyway Width	Tolerance (Js9)	Keyway Depth	Tolerance	Set Screw Size
10 and up to 12	4		1.8		M4
More than 12 and up to 17	5	±0.0150	2.3	+0.1 0	M5
More than 17 and up to 22	6		2.8		M6
More than 22 and up to 30	8	±0.0180	3.3	+0.2 0	M8
More than 30 and up to 38	10				
More than 38 and up to 44	12	±0.0215	3.8		
More than 44 and up to 50	14		4.3		M10
More than 50 and up to 58	16	4.4			
More than 58 and up to 65	18				

• Comes with two alloy steel set screws.

Model Numbering Example RS100-1B 20T – H 38 J

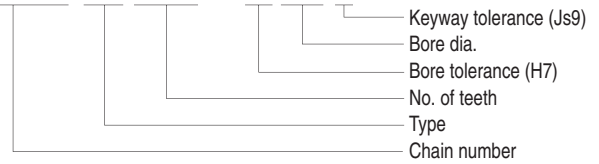

Model Number	No. of Teeth	Pitch Circle Dia. D_P	(Outer Dia.) (D_o)	Hub Dia. D_H	Hub Length L	Tap Position a	Finished Bore Dia. d						No. of Teeth	
							25	28	30	32	35	38		
RS100-1B10T-H□□J	10	102.75	117	65	50	15	○	○	○	○	○	○	○	10
RS100-1B11T-H□□J	11	112.70	127	75	50	15	○	○	○	○	○	○	○	11
RS100-1B12T-H□□J	12	122.67	138	86	50	15	○	○	○	○	⊙	○	○	12
RS100-1B13T-H□□J	13	132.67	148	88	50	15	○	○	○	○	○	⊙	○	13
RS100-1B14T-H□□J	14	142.68	158	88	50	15	○	○	○	○	○	○	○	14
RS100-1B15T-H□□J	15	152.71	168	98	50	15	○	○	○	○	⊙	○	○	15
RS100-1B16T-H□□J	16	162.75	179	98	50	15							○	16
RS100-1B17T-H□□J	17	172.79	189	107	50	15							○	17
RS100-1B18T-H□□J	18	182.84	199	107	50	15							○	18
RS100-1B19T-H□□J	19	192.90	209	107	50	15							○	19
RS100-1B20T-H□□J	20	202.96	220	107	50	15							○	20

Model Number	No. of Teeth	Pitch Circle Dia. D_P	(Outer Dia.) (D_o)	Hub Dia. D_H	Hub Length L	Tap Position a	Finished Bore Dia. d						No. of Teeth	
							40	42	45	48	50	55		60
RS100-1B10T-H□□J	10	102.75	117	65	50	15	○	○						10
RS100-1B11T-H□□J	11	112.70	127	75	50	15	○	○	○	○	○			11
RS100-1B12T-H□□J	12	122.67	138	86	50	15	○	○	○	○	⊙	⊙		12
RS100-1B13T-H□□J	13	132.67	148	88	50	15	○	○	○	○	⊙	⊙		13
RS100-1B14T-H□□J	14	142.68	158	88	50	15	○	○	○	○	○	⊙		14
RS100-1B15T-H□□J	15	152.71	168	98	50	15	○	○	○	○	⊙	⊙	⊙	15
RS100-1B16T-H□□J	16	162.75	179	98	50	15				○	⊙	⊙	⊙	16
RS100-1B17T-H□□J	17	172.79	189	107	50	15				○	○	○	⊙	17
RS100-1B18T-H□□J	18	182.84	199	107	50	15				○	⊙	⊙	⊙	18
RS100-1B19T-H□□J	19	192.90	209	107	50	15				○	○	⊙	⊙	19
RS100-1B20T-H□□J	20	202.96	220	107	50	15				○	○	○	⊙	20
RS100-1B21T-H□□J	21	213.03	230	107	50	15				○	○	○	⊙	21

Enter the bore diameter for the □ found in the model numbers.

Lock Series (with Tightening Device) S Type

Applicable models: RS35 – RS100 1B Type RS Sprockets

Allows RS standard sprockets to be mounted to shafts without using keys.

■ Features



Lock Series

1. No wobbling after mounting (tightening)
2. Easy phase alignment
3. Easy mounting and dismounting
4. No retainers required

■ Tightening Principle

The inner diameter of the sprocket and the outer diameter of the lock sleeve are tapered. When the mounting bolts are tightened, the sprocket will slide and move up on the tapered surface. A wedge action will generate force P and force P' in the radial direction to press on the shaft and tapered inner side, and frictional force will tightly secure the sprocket and shaft.

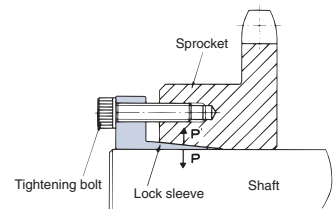

■ Bolt Tightening Positions

The same sleeve is used for all models, so some holes may not be used. Check the installation guide that comes with the product before attaching the mounting bolts for use.

■ Direction of Sprocket Movement when Tightening Bolts

When mounting a Lock Series S Type sprocket, the sprocket will move 0.5mm – 1.0mm in the direction of the shaft between the time the sprocket is initially secured and the time the sprocket is tightened. Therefore, take this movement into consideration when centering the sprocket. The amount of sprocket movement varies with the type. (See the illustration on the right.)

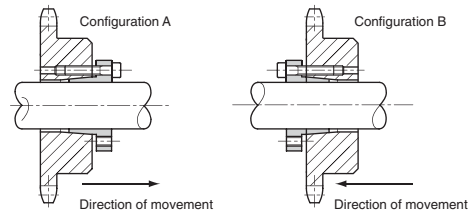

■ General Precautions

- 1) Allowable transmission torque
Ensure that the load torque does not exceed the specified transmission torque in the dimension table.
- 2) Shaft diameter tolerance and surface roughness
Use a shaft diameter tolerance of h8 and a surface roughness degree of 12S as your standards.
- 3) Mounting to shafts provided with keyways or D-shaped shafts
The allowable transmission torque will decrease by 10% when mounting the sprocket to a shaft provided with a finished keyway, such as a motor shaft, or to a D-shaped shaft.
- 4) Mounting to cold finished carbon steel bars
The allowable transmission torque will decrease by 10% when mounting the sprocket to a cold finished carbon steel bar (drawn steel with an allowable diameter of 8 – 10 class).
- 5) Ensure that the shaft is a solid shaft using S35C grade or higher steel.
- 6) Operating temperature range: -20°C to 200°C
- 7) Always use a torque wrench when tightening the bolts. (Refer to the torque wrench operation manual for proper use.)

Ordering Lock Series S Type Sprockets

Please include the product code and model number in your order.

■ Ordering Example

Product Code	Model Number	No. of Pieces	Unit
G110218	RS40-1B21T-S4825A	10	K (pcs)

■ Sleeve Mounting Configuration

Configuration A Configuration B

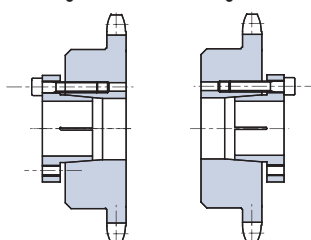

*Caution regarding sleeve mounting:
RS35-1B19T-S33□□□
RS40-1B15T-S33□□□
The above models can use configuration A only, as configuration B will cause interference with the chain.

■ Model Numbering Example

RS40-1B21T-S4825A

Chain number No. of teeth Configuration
Hub type (1B: single hub only)

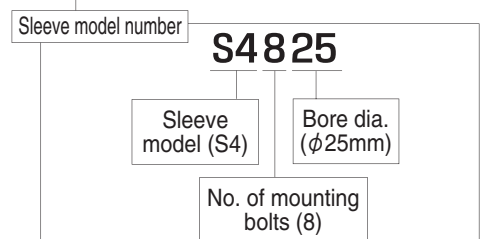

RS35 Lock Series (S Type)

RS35 Lock Series S Type, Configurations A & B

● Applicable chain pitch : 9.525mm ● Roller dia : 5.08mm

Configuration A

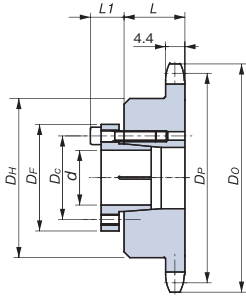

Configuration B

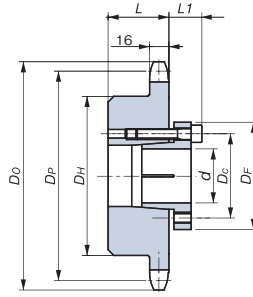

Lock Series S Type dimensions

Sleeve Model	ϕD_f (mm)	ϕD_c (mm)	L_1 (mm)	Bolt Size (M x S)	Tightening Torque (N·m)
S1	32.0	24.0	12.0	M4 x 16	4.2
S2	42.0	32.0	14.0	M5 x 18	8.3
S3	48.0	38.5	15.5	M5 x 20	8.3
S4	56.0	46.0	15.5	M5 x 20	8.3
S5	66.0	56.0	17.5	M5 x 22	8.3
S6	80.0	68.0	21.0	M6 x 25	16.8
S7	101.0	86.0	24.5	M8 x 30	40.5

Ordering Example

Example: RS35-1B, No. of teeth: 15, Sleeve configuration: A, Bore dia.: 10mm

Product Code	Model Number
G131001	RS35-1B15T-S1410A

Model Numbering Example

RS35-1B23T-S1616

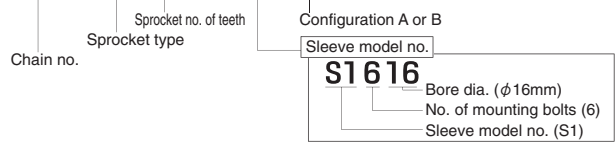

Dimensions

All models feature hardened teeth.

Model Number	Pitch Circle Dia. D_p	(Outer Dia.) (D_o)	Hub Dia. D_H	Hub Length L	Applicable Bore Dia. d											No. of Teeth	
					10	11	12	14	15	16	17	18	19	20	22		
RS35-1B15T-S14	45.81	51	35	20	●	●	●	●	●	●							15
RS35-1B16T-S14	48.82	54	37	20	●	●	●	●	●	●							16
RS35-1B17T-S14	51.84	57	41	20	●	●	●	●	●	●							17
RS35-1B17T-S24	51.84	57	41	20							●	●	●	●	●		17
RS35-1B18T-S14	54.85	60	44	20		●	●	●	●	●							18
RS35-1B18T-S24	54.85	60	44	20							●	●	●	●	●		18
RS35-1B19T-S14	57.87	63	47	20		●	●	●	●	●							19
RS35-1B19T-S24	57.87	63	47	20							●	●	●	●	●		19
RS35-1B20T-S14	60.89	66	50	20			●	●	●	●							20
RS35-1B20T-S24	60.89	66	50	20							●	●	●	●	●		20
RS35-1B21T-S16	63.91	69	53	20				●	●	●							21
RS35-1B21T-S24	63.91	69	53	20							●	●	●	●	●		21
RS35-1B22T-S16	66.93	72	53	20				●	●	●							22
RS35-1B22T-S24	66.93	72	53	20							●	●	●	●	●		22
RS35-1B23T-S16	69.95	75	53	20				●	●	●							23
RS35-1B23T-S24	69.95	75	53	20							●	●	●	●	●		23
RS35-1B24T-S16	72.97	78	53	20				●	●	●							24
RS35-1B24T-S24	72.97	78	53	20							●	●	●	●	●		24
RS35-1B25T-S16	76.00	81	53	20				●	●	●							25
RS35-1B25T-S24	76.00	81	53	20							●	●	●	●	●		25
RS35-1B26T-S16	79.02	84	53	22				●	●	●							26
RS35-1B26T-S24	79.02	84	53	22							●	●	●	●	●		26
RS35-1B27T-S16	82.05	87	53	22				●	●	●							27
RS35-1B27T-S24	82.05	87	53	22							●	●	●	●	●		27
RS35-1B28T-S16	85.07	90	53	22				●	●	●							28
RS35-1B28T-S24	85.07	90	53	22							●	●	●	●	●		28
RS35-1B30T-S16	91.12	96	53	22				●	●	●							30
RS35-1B30T-S24	91.12	96	53	22							●	●	●	●	●		30
RS35-1B32T-S16	97.18	102	53	22				●	●	●							32
RS35-1B32T-S24	97.18	102	53	22							●	●	●	●	●		32
RS35-1B34T-S16	103.23	109	53	22				●	●	●							34
RS35-1B34T-S24	103.23	109	53	22							●	●	●	●	●		34
RS35-1B35T-S16	106.26	112	53	22				●	●	●							35
RS35-1B35T-S24	106.26	112	53	22							●	●	●	●	●		35
RS35-1B36T-S16	109.29	115	53	22				●	●	●							36
RS35-1B36T-S24	109.29	115	53	22							●	●	●	●	●		36
RS35-1B38T-S16	115.34	121	63	25				●	●	●							38
RS35-1B38T-S24	115.34	121	63	25							●	●	●	●	●		38
RS35-1B40T-S16	121.40	127	63	25				●	●	●							40
RS35-1B40T-S24	121.40	127	63	25							●	●	●	●	●		40

Input the bore diameter in the white □□ boxes after the model number, and configuration A or B in the black ■ box. ● circles indicate applicable bore diameters.

RS35 Lock Series (S Type)

Dimensions

All models feature hardened teeth.

Model Number	Pitch Circle Dia. D_P	(Outer Dia.) (D_o)	Hub Dia. D_H	Hub Length L	Applicable Bore Dia. d						No. of Teeth
					24	25	28	30	32	35	
※RS35-1B19T-S33□□A	57.87	63	47	20	●	●	●				19
RS35-1B20T-S33□□■	60.89	66	50	20	●	●	●				20
RS35-1B21T-S34□□■	63.91	69	53	20	●	●	●				21
RS35-1B22T-S44□□■	66.93	72	53	20	●	●	●	●	●	●	22
RS35-1B23T-S44□□■	69.95	75	53	20	●	●	●	●	●	●	23
RS35-1B24T-S44□□■	72.97	78	53	20	●	●	●	●	●	●	24
RS35-1B25T-S44□□■	76.00	81	53	20	●	●	●	●	●	●	25
RS35-1B26T-S44□□■	79.02	84	53	22	●	●	●	●	●	●	26
RS35-1B27T-S44□□■	82.05	87	53	22	●	●	●	●	●	●	27
RS35-1B28T-S44□□■	85.07	90	53	22	●	●	●	●	●	●	28
RS35-1B30T-S44□□■	91.12	96	53	22	●	●	●	●	●	●	30
RS35-1B32T-S44□□■	97.18	102	53	22	●	●	●	●	●	●	32
RS35-1B34T-S44□□■	103.23	109	53	22	●	●	●	●	●	●	34
RS35-1B35T-S44□□■	106.26	112	53	22	●	●	●	●	●	●	35
RS35-1B36T-S44□□■	109.29	115	53	22	●	●	●	●	●	●	36
RS35-1B38T-S44□□■	115.34	121	63	25	●	●	●	●	●	●	38
RS35-1B40T-S44□□■	121.40	127	63	25	●	●	●	●	●	●	40

Input the bore diameter in the white □□ boxes after the model number, and configuration A or B in the black ■ box. ● circles indicate applicable bore diameters.
Note: Models with asterisks * indicate that only configuration A is available.

RS35 Lock Series (S Type) Maximum Allowable Torque

(Unit: N·m)

Bore dia. No. of teeth	10	11	12	14	15	16	17	18	19	20	22	24	25	28	30	32	35
	15T																
16T	58																
17T		63															
18T			69	81	86	92											
19T							158	167	177	186	205	167	174	195			
20T																	
21T				121	130	138						223	232	260			
22-40T															279	298	325

RS40 Lock Series (S Type)

RS40 Lock Series S Type, Configurations A & B

● Applicable chain pitch : 12.7mm ● Roller dia : 7.92mm

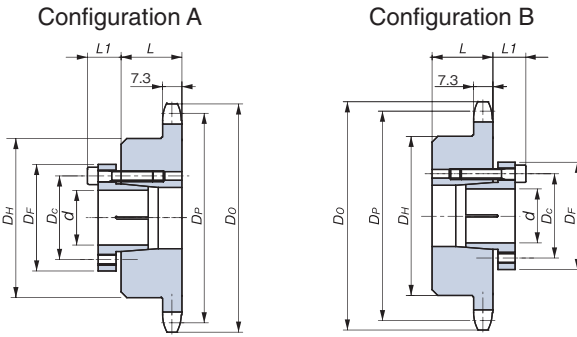

Lock Series S Type dimensions

Sleeve Model	ϕD_F (mm)	ϕD_C (mm)	L_1 (mm)	Bolt Size (M x S)	Tightening Torque (N·m)
S1	32.0	24.0	12.0	M4 × 16	4.2
S2	42.0	32.0	14.0	M5 × 18	8.3
S3	48.0	38.5	15.5	M5 × 20	8.3
S4	56.0	46.0	15.5	M5 × 20	8.3
S5	66.0	56.0	17.5	M5 × 22	8.3
S6	80.0	68.0	21.0	M6 × 25	16.8
S7	101.0	86.0	24.5	M8 × 30	40.5

Ordering Example

Example: RS40-1B, No. of teeth: 14, Sleeve configuration: A, Bore dia.: 14mm

Product Code	Model Number
G131266	RS40-1B14T-S1614A

Model Numbering Example

RS40-1B21T-S4825

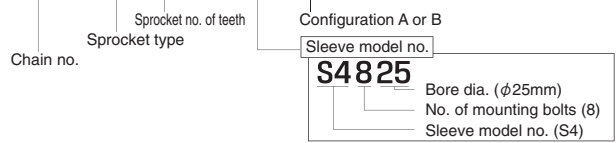

Dimensions

All models feature hardened teeth.

Model Number	Pitch Circle Dia. D_P	(Outer Dia.) (D_o)	Hub Dia. D_H	Hub Length L	Applicable Bore Dia. d								No. of Teeth	
					14	15	16	17	18	19	20	22		
RS40-1B14T-S16□□■	57.07	63	42	22	●									14
RS40-1B14T-S24□□■						●								14
RS40-1B15T-S16□□■	61.08	67	46	22	●									15
RS40-1B15T-S24□□■						●								15
RS40-1B16T-S16□□■	65.10	71	50	22	●									16
RS40-1B16T-S24□□■						●								16
RS40-1B17T-S24□□■	69.12	76	54	22		●								17
RS40-1B18T-S24□□■	73.14	80	57	22		●								18
RS40-1B19T-S24□□■	77.16	84	62	22		●								19
RS40-1B20T-S25□□■	81.18	88	67	25		●								20
RS40-1B21T-S25□□■	85.21	92	71	25		●								21
RS40-1B22T-S25□□■	89.24	96	75	25		●								22
RS40-1B23T-S25□□■	93.27	100	77	25		●								23
RS40-1B24T-S25□□■	97.30	104	63	25		●								24
RS40-1B25T-S25□□■	101.33	108	63	25			●							25
RS40-1B26T-S25□□■	105.36	112	63	25				●						26
RS40-1B27T-S25□□■	109.40	116	63	25				●						27
RS40-1B28T-S25□□■	113.43	120	63	25				●						28
RS40-1B30T-S25□□■	121.50	128	63	25					●					30
RS40-1B32T-S25□□■	129.57	137	68	28						●				32

Input the bore diameter in the white □□ boxes after the model number, and configuration A or B in the black ■ box. ● circles indicate applicable bore diameters.

RS40 Lock Series (S Type)

■ Dimensions

All models feature hardened teeth.

Model Number	Pitch Circle Dia. D_P	(Outer Dia.) (D_o)	Hub Dia. D_H	Hub Length L	Applicable Bore Dia. d										No. of Teeth	
					24	25	28	30	32	35	38	40	42	45		
※RS40-1B15T-S33□□□A	61.08	67	46	22	●	●	●									15
RS40-1B16T-S33□□□■	65.10	71	50	22	●	●	●									16
RS40-1B17T-S44□□□■	69.12	76	54	22	●	●	●	●	●	●						17
RS40-1B18T-S44□□□■	73.14	80	57	22	●	●	●	●	●	●						18
RS40-1B19T-S44□□□■	77.16	84	62	22	●	●	●	●	●	●						19
RS40-1B20T-S48□□□■	81.18	88	67	25	●	●	●	●	●	●						20
RS40-1B20T-S56□□□■											●	●	●	●		
RS40-1B21T-S48□□□■	85.21	92	71	25	●	●	●	●	●	●						21
RS40-1B21T-S56□□□■												●	●	●	●	
RS40-1B22T-S48□□□■	89.24	96	75	25	●	●	●	●	●	●						22
RS40-1B22T-S56□□□■													●	●	●	●
RS40-1B23T-S48□□□■	93.27	100	77	25	●	●	●	●	●	●						23
RS40-1B23T-S56□□□■														●	●	●
RS40-1B24T-S48□□□■	97.30	104	63	25	●	●	●	●	●	●						24
RS40-1B24T-S56□□□■														●	●	●
RS40-1B25T-S48□□□■	101.33	108	63	25	●	●	●	●	●	●						25
RS40-1B25T-S56□□□■														●	●	●
RS40-1B26T-S48□□□■	105.36	112	63	25	●	●	●	●	●	●						26
RS40-1B26T-S56□□□■														●	●	●
RS40-1B27T-S48□□□■	109.40	116	63	25	●	●	●	●	●	●						27
RS40-1B27T-S56□□□■														●	●	●
RS40-1B28T-S48□□□■	113.43	120	63	25	●	●	●	●	●	●						28
RS40-1B28T-S56□□□■														●	●	●
RS40-1B30T-S48□□□■	121.50	128	63	25	●	●	●	●	●	●						30
RS40-1B30T-S56□□□■														●	●	●
RS40-1B32T-S48□□□■	129.57	137	68	28	●	●	●	●	●	●						32
RS40-1B32T-S56□□□■														●	●	●
RS40-1B34T-S48□□□■	137.64	145	68	28	●	●	●	●	●	●						34
RS40-1B34T-S56□□□■														●	●	●
RS40-1B35T-S48□□□■	141.68	149	68	28	●	●	●	●	●	●						35
RS40-1B35T-S56□□□■														●	●	●
RS40-1B36T-S48□□□■	145.72	153	68	28	●	●	●	●	●	●						36
RS40-1B36T-S56□□□■														●	●	●
RS40-1B38T-S48□□□■	153.79	161	68	28	●	●	●	●	●	●						38
RS40-1B38T-S56□□□■														●	●	●
RS40-1B40T-S48□□□■	161.87	169	68	28	●	●	●	●	●	●						40
RS40-1B40T-S56□□□■														●	●	●

Input the bore diameter in the white □□ boxes after the model number, and configuration A or B in the black ■ box. ● circles indicate applicable bore diameters. Note: Models with asterisks * indicate that only configuration A is available.

■ RS40 Lock Series (S Type) Maximum Allowable Torque (Unit: N·m)

Bore dia. No. of teeth	14	15	16	17	18	19	20	22	24	25	28	30	32	35	38	40	42	45
14T																		
15T	121																	
16T		139	149						167	174	195							
17T				158	167	177	186	205										
18T									223	232	260	279	298	325				
19T																		
20T																		
21T																		
22T		174																
23T			186															
24T				198	209	221	232	256										
25T									446	465	521	558	595	651	530	558	586	628
26T																		
27T																		
28T																		
30T																		
32T																		
34-40T																		

RS50 Lock Series (S Type)

RS50 Lock Series S Type, Configurations A & B

● Applicable chain pitch : 15.875mm ● Roller dia : 10.16mm

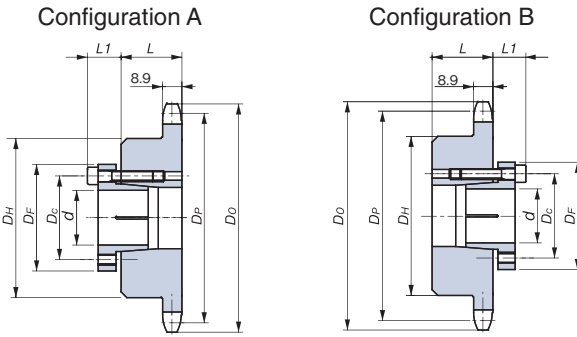

Lock Series S Type dimensions

Sleeve Model	ϕD_F (mm)	ϕD_C (mm)	L_1 (mm)	Bolt Size (M x S)	Tightening Torque (N·m)
S1	32.0	24.0	12.0	M4 x 16	4.2
S2	42.0	32.0	14.0	M5 x 18	8.3
S3	48.0	38.5	15.5	M5 x 20	8.3
S4	56.0	46.0	15.5	M5 x 20	8.3
S5	66.0	56.0	17.5	M5 x 22	8.3
S6	80.0	68.0	21.0	M6 x 25	16.8
S7	101.0	86.0	24.5	M8 x 30	40.5

Ordering Example

Example: RS50-1B, No. of teeth: 14, Sleeve configuration: A, Bore dia.: 15mm

Product Code	Model Number
G131562	RS50-1B14T-S2515A

Model Numbering Example

RS50-1B20T-S4828

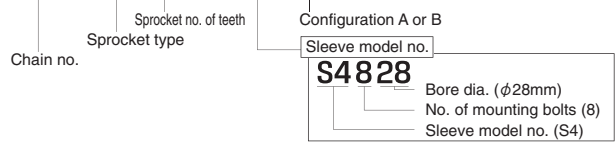

Dimensions

Teeth hardened up to 35T.

Model Number	Pitch Circle Dia. D_P	(Outer Dia.) (D_o)	Hub Dia. D_H	Hub Length L	Applicable Bore Dia. d										No. of Teeth			
					15	16	17	18	19	20	22	24	25	28		30		
RS50-1B14T-S25	71.34	79	52	25	●	●											14	
RS50-1B14T-S26					●	●	●	●	●	●								15
RS50-1B15T-S25	76.35	84	57	25			●	●	●	●								16
RS50-1B15T-S26							●	●	●	●	●							17
RS50-1B15T-S44												●	●	●	●			18
RS50-1B16T-S25	81.37	89	62	25	●	●												19
RS50-1B16T-S26							●	●	●	●	●							20
RS50-1B16T-S44												●	●	●	●			21
RS50-1B17T-S26	86.39	94	67	25						●	●							22
RS50-1B17T-S48												●	●	●	●			23
RS50-1B18T-S26	91.42	100	72	28							●							24
RS50-1B18T-S48												●	●	●	●			25
RS50-1B19T-S26	96.45	105	73	28							●							26
RS50-1B19T-S48												●	●	●	●			27
RS50-1B20T-S48	101.48	110	73	28								●	●	●	●			28
RS50-1B21T-S48	106.51	115	73	28								●	●	●	●			29
RS50-1B22T-S48	111.55	120	73	28								●	●	●	●			30
RS50-1B23T-S48	116.59	125	73	28								●	●	●	●			31
RS50-1B24T-S48	121.62	130	73	28								●	●	●	●			32
RS50-1B25T-S48	126.66	135	73	28								●	●	●	●			33
RS50-1B26T-S48	131.70	140	73	28								●	●	●	●			34
RS50-1B27T-S48	136.74	145	73	28								●	●	●	●			
RS50-1B28T-S48	141.79	150	73	28									●	●	●			
RS50-1B30T-S48	151.87	161	73	28										●	●			
RS50-1B32T-S48	161.96	171	73	28											●	●		
RS50-1B34T-S48	172.05	181	73	28												●	●	

Input the bore diameter in the white □□ boxes after the model number, and configuration A or B in the black ■ box. ● circles indicate applicable bore diameters.

RS50 Lock Series (S Type)

■ Dimensions

Teeth hardened up to 35T.

Model Number	Pitch Circle Dia. D_P	(Outer Dia.) (D_o)	Hub Dia. D_H	Hub Length L	Applicable Bore Dia. d									No. of Teeth						
					32	35	38	40	42	45	48	50	55							
RS50-1B15T-S44 <input type="checkbox"/> <input type="checkbox"/> <input type="checkbox"/> <input type="checkbox"/>	76.35	84	57	25	●	●														15
RS50-1B16T-S44 <input type="checkbox"/> <input type="checkbox"/> <input type="checkbox"/> <input type="checkbox"/>	81.37	89	62	25	●	●														16
RS50-1B17T-S48 <input type="checkbox"/> <input type="checkbox"/> <input type="checkbox"/> <input type="checkbox"/>	86.39	94	67	25	●	●														17
RS50-1B17T-S56 <input type="checkbox"/> <input type="checkbox"/> <input type="checkbox"/> <input type="checkbox"/>						●	●													
RS50-1B18T-S48 <input type="checkbox"/> <input type="checkbox"/> <input type="checkbox"/> <input type="checkbox"/>	91.42	100	72	28	●	●														18
RS50-1B18T-S56 <input type="checkbox"/> <input type="checkbox"/> <input type="checkbox"/> <input type="checkbox"/>						●	●													
RS50-1B19T-S48 <input type="checkbox"/> <input type="checkbox"/> <input type="checkbox"/> <input type="checkbox"/>	96.45	105	73	28	●	●														19
RS50-1B19T-S56 <input type="checkbox"/> <input type="checkbox"/> <input type="checkbox"/> <input type="checkbox"/>						●	●													
RS50-1B20T-S48 <input type="checkbox"/> <input type="checkbox"/> <input type="checkbox"/> <input type="checkbox"/>	101.48	110	73	28	●	●														20
RS50-1B20T-S56 <input type="checkbox"/> <input type="checkbox"/> <input type="checkbox"/> <input type="checkbox"/>						●	●													
RS50-1B21T-S48 <input type="checkbox"/> <input type="checkbox"/> <input type="checkbox"/> <input type="checkbox"/>	106.51	115	73	28	●	●														21
RS50-1B21T-S56 <input type="checkbox"/> <input type="checkbox"/> <input type="checkbox"/> <input type="checkbox"/>						●	●													
RS50-1B22T-S48 <input type="checkbox"/> <input type="checkbox"/> <input type="checkbox"/> <input type="checkbox"/>	111.55	120	73	28	●	●														22
RS50-1B22T-S56 <input type="checkbox"/> <input type="checkbox"/> <input type="checkbox"/> <input type="checkbox"/>						●	●													
RS50-1B23T-S48 <input type="checkbox"/> <input type="checkbox"/> <input type="checkbox"/> <input type="checkbox"/>	116.59	125	73	28	●	●														23
RS50-1B23T-S56 <input type="checkbox"/> <input type="checkbox"/> <input type="checkbox"/> <input type="checkbox"/>						●	●													
RS50-1B24T-S48 <input type="checkbox"/> <input type="checkbox"/> <input type="checkbox"/> <input type="checkbox"/>	121.62	130	73	28	●	●														24
RS50-1B24T-S56 <input type="checkbox"/> <input type="checkbox"/> <input type="checkbox"/> <input type="checkbox"/>						●	●													
RS50-1B25T-S48 <input type="checkbox"/> <input type="checkbox"/> <input type="checkbox"/> <input type="checkbox"/>	126.66	135	73	28	●	●														25
RS50-1B25T-S56 <input type="checkbox"/> <input type="checkbox"/> <input type="checkbox"/> <input type="checkbox"/>						●	●													
RS50-1B26T-S48 <input type="checkbox"/> <input type="checkbox"/> <input type="checkbox"/> <input type="checkbox"/>	131.70	140	73	28	●	●														26
RS50-1B26T-S56 <input type="checkbox"/> <input type="checkbox"/> <input type="checkbox"/> <input type="checkbox"/>						●	●													
RS50-1B27T-S48 <input type="checkbox"/> <input type="checkbox"/> <input type="checkbox"/> <input type="checkbox"/>	136.74	145	73	28	●	●														27
RS50-1B27T-S56 <input type="checkbox"/> <input type="checkbox"/> <input type="checkbox"/> <input type="checkbox"/>						●	●													
RS50-1B28T-S48 <input type="checkbox"/> <input type="checkbox"/> <input type="checkbox"/> <input type="checkbox"/>	141.79	150	73	28	●	●														28
RS50-1B28T-S56 <input type="checkbox"/> <input type="checkbox"/> <input type="checkbox"/> <input type="checkbox"/>						●	●													
RS50-1B30T-S48 <input type="checkbox"/> <input type="checkbox"/> <input type="checkbox"/> <input type="checkbox"/>	151.87	161	73	28	●	●														30
RS50-1B30T-S56 <input type="checkbox"/> <input type="checkbox"/> <input type="checkbox"/> <input type="checkbox"/>						●	●													
RS50-1B32T-S48 <input type="checkbox"/> <input type="checkbox"/> <input type="checkbox"/> <input type="checkbox"/>	161.96	171	73	28	●	●														32
RS50-1B32T-S56 <input type="checkbox"/> <input type="checkbox"/> <input type="checkbox"/> <input type="checkbox"/>						●	●													
RS50-1B34T-S48 <input type="checkbox"/> <input type="checkbox"/> <input type="checkbox"/> <input type="checkbox"/>	172.05	181	73	28	●	●														34
RS50-1B34T-S56 <input type="checkbox"/> <input type="checkbox"/> <input type="checkbox"/> <input type="checkbox"/>						●	●													
RS50-1B35T-S48 <input type="checkbox"/> <input type="checkbox"/> <input type="checkbox"/> <input type="checkbox"/>	177.10	186	73	28	●	●														35
RS50-1B35T-S56 <input type="checkbox"/> <input type="checkbox"/> <input type="checkbox"/> <input type="checkbox"/>						●	●													
RS50-1B36T-S510 <input type="checkbox"/> <input type="checkbox"/> <input type="checkbox"/> <input type="checkbox"/>	182.15	191	83	35				●	●	●	●									36
RS50-1B36T-S66 <input type="checkbox"/> <input type="checkbox"/> <input type="checkbox"/> <input type="checkbox"/>																				
RS50-1B38T-S510 <input type="checkbox"/> <input type="checkbox"/> <input type="checkbox"/> <input type="checkbox"/>	192.24	201	83	35				●	●	●	●									38
RS50-1B38T-S66 <input type="checkbox"/> <input type="checkbox"/> <input type="checkbox"/> <input type="checkbox"/>																				
RS50-1B40T-S510 <input type="checkbox"/> <input type="checkbox"/> <input type="checkbox"/> <input type="checkbox"/>	202.33	211	83	35				●	●	●	●									40
RS50-1B40T-S66 <input type="checkbox"/> <input type="checkbox"/> <input type="checkbox"/> <input type="checkbox"/>																				

Input the bore diameter in the white boxes after the model number, and configuration A or B in the black box. ● circles indicate applicable bore diameters.

■ RS50 Lock Series (S Type) Maximum Allowable Torque

(Unit: N·m)

Bore dia. No. of teeth	No. of teeth																			
	15	16	17	18	19	20	22	24	25	28	30	32	35	38	40	42	45	48	50	55
14T																				
15T	174	186	237	251	265	279		223	232	260	279	298	325							
16T							307													
17T																				
18T																				
19T																				
20T																				
21T																				
22T								446												
23T																				
24T									465	521	558	595	651	530	558	586	628			
25T																				
26T																				
27T																				
28T																				
30T																				
32T																				
34T																				
35T																				
36-40T														883	930	976	1046	1116	1162	1279

Before Use
Standard Roller Chains
Lube-Free Roller Chains
Heavy Duty Roller Chains
Corrosion Resistant Roller Chains
Specialty Roller Chains
Sprockets
Pin Gear Drives
Accessories
Selection
Handling

RS60 Lock Series (S Type)

RS60 Lock Series S Type, Configurations A & B

● Applicable chain pitch : 19.05mm ● Roller dia : 11.91mm

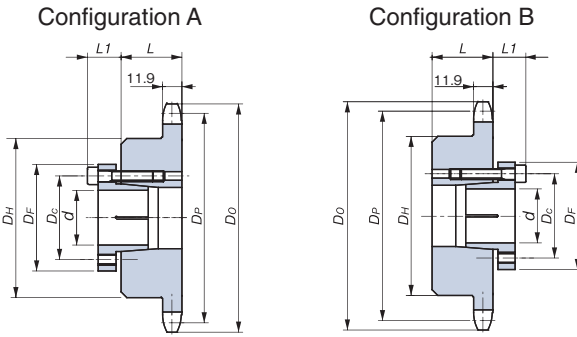

Lock Series S Type dimensions

Sleeve Model	ϕD_F (mm)	ϕD_C (mm)	L_1 (mm)	Bolt Size (M x S)	Tightening Torque (N·m)
S1	32.0	24.0	12.0	M4 x 16	4.2
S2	42.0	32.0	14.0	M5 x 18	8.3
S3	48.0	38.5	15.5	M5 x 20	8.3
S4	56.0	46.0	15.5	M5 x 20	8.3
S5	66.0	56.0	17.5	M5 x 22	8.3
S6	80.0	68.0	21.0	M6 x 25	16.8
S7	101.0	86.0	24.5	M8 x 30	40.5

Ordering Example

Example: RS60-1B, No. of teeth: 12, Sleeve configuration: A, Bore dia.: 18mm

Product Code	Model Number
G131765	RS60-1B12T-S2618A

Model Numbering Example

RS60-1B16T-S4828

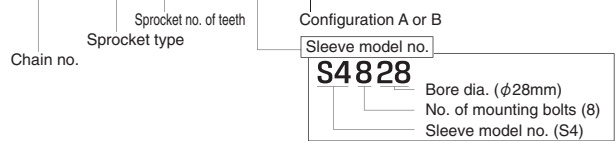

Dimensions

Teeth hardened up to 30T.

Model Number	Pitch Circle Dia. D_P	(Outer Dia.) (D_o)	Hub Dia. D_H	Hub Length L	Applicable Bore Dia. d										No. of Teeth	
					18	19	20	22	24	25	28	30	32	35		
RS60-1B12T-S26 <input type="checkbox"/> <input type="checkbox"/> <input checked="" type="checkbox"/>	73.60	83	51	32	●	●	●	●								12
RS60-1B13T-S26 <input type="checkbox"/> <input type="checkbox"/> <input checked="" type="checkbox"/>	79.60	89	57	32	●	●	●	●								13
RS60-1B13T-S46 <input type="checkbox"/> <input type="checkbox"/> <input checked="" type="checkbox"/>									●	●	●	●	●	●		13
RS60-1B14T-S26 <input type="checkbox"/> <input type="checkbox"/> <input checked="" type="checkbox"/>	85.61	95	62	32	●	●	●	●								14
RS60-1B14T-S46 <input type="checkbox"/> <input type="checkbox"/> <input checked="" type="checkbox"/>									●	●	●	●	●	●		14
RS60-1B15T-S48 <input type="checkbox"/> <input type="checkbox"/> <input checked="" type="checkbox"/>	91.63	101	68	32					●	●	●	●	●	●		15
RS60-1B16T-S48 <input type="checkbox"/> <input type="checkbox"/> <input checked="" type="checkbox"/>	97.65	107	73	32					●	●	●	●	●	●		16
RS60-1B17T-S48 <input type="checkbox"/> <input type="checkbox"/> <input checked="" type="checkbox"/>	103.67	113	73	32						●	●	●	●	●		17
RS60-1B18T-S48 <input type="checkbox"/> <input type="checkbox"/> <input checked="" type="checkbox"/>	109.70	119	83	40							●	●	●	●		18
RS60-1B19T-S48 <input type="checkbox"/> <input type="checkbox"/> <input checked="" type="checkbox"/>	115.74	126	83	40							●	●	●	●		19
RS60-1B20T-S48 <input type="checkbox"/> <input type="checkbox"/> <input checked="" type="checkbox"/>	121.78	132	83	40								●	●	●		20
RS60-1B21T-S48 <input type="checkbox"/> <input type="checkbox"/> <input checked="" type="checkbox"/>	127.82	138	83	40									●	●		21
RS60-1B22T-S48 <input type="checkbox"/> <input type="checkbox"/> <input checked="" type="checkbox"/>	133.86	144	83	40										●		22
RS60-1B23T-S48 <input type="checkbox"/> <input type="checkbox"/> <input checked="" type="checkbox"/>	139.90	150	83	40											●	23
RS60-1B24T-S48 <input type="checkbox"/> <input type="checkbox"/> <input checked="" type="checkbox"/>	145.95	156	83	40											●	24
RS60-1B25T-S48 <input type="checkbox"/> <input type="checkbox"/> <input checked="" type="checkbox"/>	151.99	162	83	40											●	25

Input the bore diameter in the white boxes after the model number, and configuration A or B in the black box. ● circles indicate applicable bore diameters.

RS60 Lock Series (S Type)

■ Dimensions

Teeth hardened up to 30T.

Model Number	Pitch Circle Dia. <i>D_P</i>	(Outer Dia.) <i>(D_O)</i>	Hub Dia. <i>D_H</i>	Hub Length <i>L</i>	Applicable Bore Dia. <i>d</i>							No. of Teeth
					38	40	42	45	48	50	55	
RS60-1B15T-S56□□■	91.63	101	68	32	●	●	●	●				15
RS60-1B16T-S56□□■	97.65	107	73	32	●	●	●	●				16
RS60-1B17T-S56□□■	103.67	113	73	32	●	●	●	●				17
RS60-1B18T-S510□□■	109.70	119	83	40	●	●	●	●				18
RS60-1B18T-S66□□■									●	●	●	
RS60-1B19T-S510□□■	115.74	126	83	40	●	●	●	●				19
RS60-1B19T-S66□□■									●	●	●	
RS60-1B20T-S510□□■	121.78	132	83	40	●	●	●	●				20
RS60-1B20T-S66□□■									●	●	●	
RS60-1B21T-S510□□■	127.82	138	83	40	●	●	●	●				21
RS60-1B21T-S66□□■									●	●	●	
RS60-1B22T-S510□□■	133.86	144	83	40	●	●	●	●				22
RS60-1B22T-S66□□■									●	●	●	
RS60-1B23T-S510□□■	139.90	150	83	40	●	●	●	●				23
RS60-1B23T-S66□□■									●	●	●	
RS60-1B24T-S510□□■	145.95	156	83	40	●	●	●	●				24
RS60-1B24T-S66□□■									●	●	●	
RS60-1B25T-S510□□■	151.99	162	83	40	●	●	●	●				25
RS60-1B25T-S66□□■									●	●	●	
RS60-1B26T-S510□□■	158.04	168	83	40	●	●	●	●				26
RS60-1B26T-S66□□■									●	●	●	
RS60-1B27T-S510□□■	164.09	174	83	40	●	●	●	●				27
RS60-1B27T-S66□□■									●	●	●	
RS60-1B28T-S510□□■	170.14	180	83	40	●	●	●	●				28
RS60-1B28T-S66□□■									●	●	●	
RS60-1B30T-S510□□■	182.25	193	83	40	●	●	●	●				30
RS60-1B30T-S66□□■									●	●	●	
RS60-1B32T-S510□□■	194.35	205	83	40	●	●	●	●				32
RS60-1B32T-S66□□■									●	●	●	
RS60-1B34T-S510□□■	206.46	217	83	40		●	●	●				34
RS60-1B34T-S66□□■										●	●	
RS60-1B35T-S510□□■	212.52	223	83	40				●				35
RS60-1B35T-S66□□■											●	
RS60-1B36T-S510□□■	218.57	229	83	40				●				36
RS60-1B36T-S66□□■											●	
RS60-1B38T-S510□□■	230.69	241	83	40				●				38
RS60-1B38T-S66□□■											●	
RS60-1B40T-S66□□■	242.80	253	83	40				●	●	●		40

Input the bore diameter in the white □□ boxes after the model number, and configuration A or B in the black ■ box. ● circles indicate applicable bore diameters.

■ RS60 Lock Series (S Type) Maximum Allowable Torque

(Unit: N·m)

Bore No. of teeth	18	19	20	22	24	25	28	30	32	35	38	40	42	45	48	50	55
12T																	
13T	251	265	279	307													
14T					335	349	391	418	446	488							
15T																	
16T					446	465					530	558	586	628			
17T							521	558									
18T									595								
19T										651							
20T																	
21T																	
22T																	
23T											883						
24T												930	976				
25T																	
26T														1046			
27T															1116	1162	1279
28T																	
30T																	
32T																	
34T																	
35T																	
36T																	
38T																	
40T																	

Before Use
 Standard Roller Chains
 Lube-Free Roller Chains
 Heavy Duty Roller Chains
 Corrosion Resistant Roller Chains
 Specialty Roller Chains
 Sprockets
 Pin Gear Drives
 Accessories
 Selection
 Handling

RS80 Lock Series (S Type)

RS80 Lock Series S Type, Configurations A & B

● Applicable chain pitch : 25.4mm ● Roller dia : 15.88mm

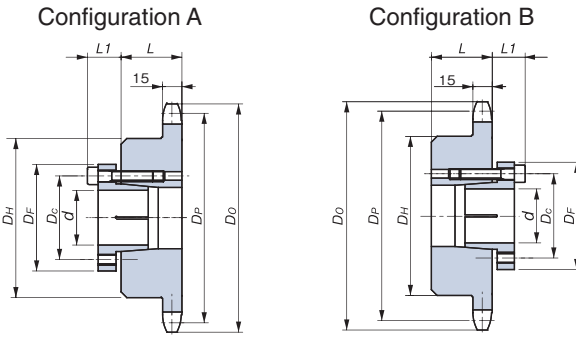

Lock Series S Type dimensions

Sleeve Model	ϕD_F (mm)	ϕD_C (mm)	L_1 (mm)	Bolt Size (M x S)	Tightening Torque (N·m)
S1	32.0	24.0	12.0	M4 x 16	4.2
S2	42.0	32.0	14.0	M5 x 18	8.3
S3	48.0	38.5	15.5	M5 x 20	8.3
S4	56.0	46.0	15.5	M5 x 20	8.3
S5	66.0	56.0	17.5	M5 x 22	8.3
S6	80.0	68.0	21.0	M6 x 25	16.8
S7	101.0	86.0	24.5	M8 x 30	40.5

Ordering Example

Example: RS80-1B, No. of teeth: 12, Sleeve configuration: A, Bore dia.: 24mm

Product Code	Model Number
G133001	RS80-1B12T-S4824A

Model Numbering Example

RS80-1B18T-S51038

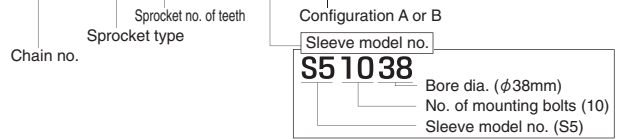

Dimensions

Teeth hardened up to 21T.

Model Number	Pitch Circle Dia. D_P	(Outer Dia.) (D_O)	Hub Dia. D_H	Hub Length L	Applicable Bore Dia. d										No. of Teeth	
					24	25	28	30	32	35	38	40	42	45		
RS80-1B12T-S48□□■	98.14	110	67	40	●	●	●	●	●	●						12
RS80-1B13T-S48□□■	106.14	118	77	40	●	●	●	●	●	●						13
RS80-1B13T-S510□□■										●	●	●	●			
RS80-1B14T-S48□□■	114.15	127	77	40	●	●	●	●	●							14
RS80-1B14T-S510□□■												●	●	●	●	●
RS80-1B15T-S510□□■	122.17	135	93	40						●	●	●	●	●		15
RS80-1B16T-S510□□■	130.20	143	93	40						●	●	●	●	●		16
RS80-1B17T-S510□□■	138.23	151	93	40						●	●	●	●	●		17
RS80-1B18T-S510□□■	146.27	159	93	40						●	●	●	●	●		18
RS80-1B19T-S510□□■	154.32	167	93	40						●	●	●	●	●		19
RS80-1B20T-S510□□■	162.37	176	93	40						●	●	●	●	●		20
RS80-1B21T-S510□□■	170.42	184	93	40						●	●	●	●	●		21

Input the bore diameter in the white □□ boxes after the model number, and configuration A or B in the black ■ box. ● circles indicate applicable bore diameters.

RS80 Lock Series (S Type)

■ Dimensions

Teeth hardened up to 21T.

Model Number	Pitch Circle Dia. D_P	(Outer Dia.) (D_o)	Hub Dia. D_H	Hub Length L	Applicable Bore Dia. d						No. of Teeth
					48	50	55	60	65	70	
RS80-1B15T-S66□□■	122.17	135	93	40	●	●	●				15
RS80-1B16T-S66□□■	130.20	143	93	40	●	●	●				16
RS80-1B17T-S66□□■	138.23	151	93	40	●	●	●				17
RS80-1B18T-S66□□■	146.27	159	93	40	●	●	●				18
RS80-1B19T-S66□□■	154.32	167	93	40	●	●	●				19
RS80-1B20T-S68□□■	162.37	176	93	40	●	●	●				20
RS80-1B21T-S68□□■	170.42	184	93	40	●	●	●				21
RS80-1B22T-S612□□■	178.48	192	107	45	●	●	●				22
RS80-1B22T-S75□□■								●	●	●	
RS80-1B23T-S612□□■	186.54	200	107	45	●	●	●				23
RS80-1B23T-S75□□■								●	●	●	
RS80-1B24T-S612□□■	194.60	208	107	45	●	●	●				24
RS80-1B24T-S75□□■								●	●	●	
RS80-1B25T-S612□□■	202.66	216	107	45	●	●	●				25
RS80-1B25T-S75□□■								●	●	●	
RS80-1B26T-S612□□■	210.72	224	107	45	●	●	●				26
RS80-1B26T-S75□□■								●	●	●	
RS80-1B27T-S612□□■	218.79	233	107	45	●	●	●				27
RS80-1B27T-S75□□■								●	●	●	
RS80-1B28T-S612□□■	226.86	241	107	45	●	●	●				28
RS80-1B28T-S75□□■								●	●	●	
RS80-1B30T-S612□□■	243.00	257	107	45	●	●	●				30
RS80-1B30T-S75□□■								●	●	●	
RS80-1B32T-S612□□■	259.14	273	107	45	●	●	●				32
RS80-1B32T-S75□□■								●	●	●	
RS80-1B34T-S612□□■	275.28	289	107	45	●	●	●				34
RS80-1B34T-S75□□■								●	●	●	
RS80-1B35T-S612□□■	283.36	297	107	45	●	●	●				35
RS80-1B35T-S75□□■								●	●	●	

Input the bore diameter in the white □□ boxes after the model number, and configuration A or B in the black ■ box. ● circles indicate applicable bore diameters.

■ RS80 Lock Series (S Type) Maximum Allowable Torque

(Unit: N·m)

Bore dia. No. of teeth	24	25	28	30	32	35	38	40	42	45	48	50	55	60	65	70
12T																
13T	446	465	521	558	595	651										
14T																
15T																
16T																
17T							883	930	976	1046	1116	1162	1279			
18T						814										
19T																
20T																
21T											1275	1329	1461			
22-35T											2232	2325	2557	2140	2319	2497

RS100 Lock Series (S Type)

RS100 Lock Series S Type, Configurations A & B

● Applicable chain pitch : 31.75mm ● Roller dia : 19.05mm

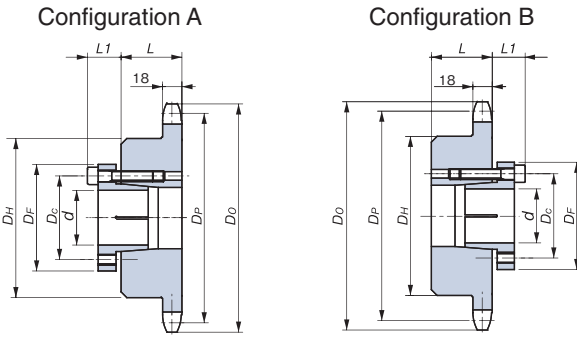

Lock Series S Type dimensions

Sleeve Model	ϕD_F (mm)	ϕD_C (mm)	L_1 (mm)	Bolt Size (M x S)	Tightening Torque (N·m)
S1	32.0	24.0	12.0	M4 x 16	4.2
S2	42.0	32.0	14.0	M5 x 18	8.3
S3	48.0	38.5	15.5	M5 x 20	8.3
S4	56.0	46.0	15.5	M5 x 20	8.3
S5	66.0	56.0	17.5	M5 x 22	8.3
S6	80.0	68.0	21.0	M6 x 25	16.8
S7	101.0	86.0	24.5	M8 x 30	40.5

Ordering Example

Example: RS100-1B, No. of teeth: 13, Sleeve configuration: A, Bore dia.: 48mm

Product Code	Model Number
G133149	RS100-B13T-S6848A

Model Numbering Example

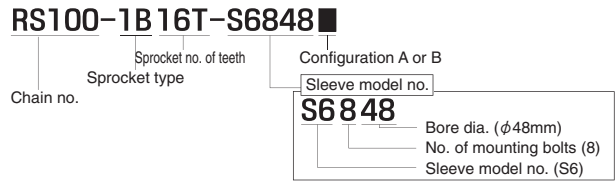

Dimensions

All models feature hardened teeth.

Model Number	Pitch Circle Dia. D_P	(Outer Dia.) (D_O)	Hub Dia. D_H	Hub Length L	Applicable Bore Dia. d						No. of Teeth
					48	50	55	60	65	70	
RS100-1B13T-S68	132.67	148	88	50	●	●	●				13
RS100-1B14T-S68	142.68	158	88	50	●	●	●				14
RS100-1B15T-S68	152.71	168	98	50	●	●	●				15
RS100-1B16T-S68	162.75	179	98	50	●	●	●				16
RS100-1B17T-S612	172.79	189	107	50	●	●	●				17
RS100-1B17T-S75								●	●	●	
RS100-1B18T-S612	182.84	199	107	50	●	●	●				18
RS100-1B18T-S75								●	●	●	
RS100-1B19T-S612	192.90	209	107	50	●	●	●				19
RS100-1B19T-S75								●	●	●	
RS100-1B20T-S612	202.96	220	107	50	●	●	●				20
RS100-1B20T-S75								●	●	●	
RS100-1B21T-S612	213.03	230	107	50	●	●	●				21
RS100-1B21T-S75								●	●	●	

Input the bore diameter in the white boxes after the model number, and configuration A or B in the black box. ● circles indicate applicable bore diameters.

RS100 Lock Series (S Type) Maximum Allowable Torque (Unit: N·m)

No. of teeth	48	50	55	60	65	70
13T						
14T	1488	1550	1705			
15T						
16T						
17T	2232	2325	2257	2140	2319	2497
18T						
19T						
20T						
21T						

Lock Series (with Tightening Device) N Type

Applicable models: RS35 – RS60 1B Type RS Sprockets
 Allows RS standard sprockets to be mounted to shafts without using keys.



■ Features

- 1. Greatly increases work efficiency**
 Unlike conventional products that require a number of tightening bolts, this type can be simply tightened with a nut and coupled to a shaft with ease. Furthermore, it can be easily dismounted for fine-adjustment and mounted again.
- 2. Suitable for small shaft diameters**
 Tsubaki offers standard models with diameters ranging from 7 – 28mm to match a wide-variety of customer needs.
- 3. Compact design**
 Features a compact design with strength calculations that take the maximum allowable load of the chain in mind while eliminating any waste.

■ General Precautions

- 1) Allowable transmission torque
 Ensure that the load torque does not exceed the specified transmission torque in the dimension table.
- 2) Shaft diameter tolerance and surface roughness
 Use a shaft diameter tolerance of h8 and a surface roughness degree of 12S as your standards.
- 3) Mounting to shafts provided with keyways or D-shaped shafts
 The allowable transmission torque will decrease by 10% when mounting the sprocket to a shaft provided with a finished keyway, such as a motor shaft, or to a D-shaped shaft.
- 4) Mounting to cold finished carbon steel bars
 The allowable transmission torque will decrease by 10% when mounting the sprocket to a cold finished carbon steel bar (drawn steel with an allowable diameter of 8 – 10 class).
- 5) Ensure that the shaft is a solid shaft using S35C grade or higher steel.
- 6) Operating temperature range: -20°C to 200°C
- 7) Always use a torque wrench when tightening the bolts. (Refer to the torque wrench operation manual for proper use.)

Ordering Lock Series N Type Sprockets

Please include the product code and model number in your order.

■ Ordering Example

Model Number	No. of Pieces	Unit
RS40-1B21T-N417A	10	K (pcs)

■ Ordering Example

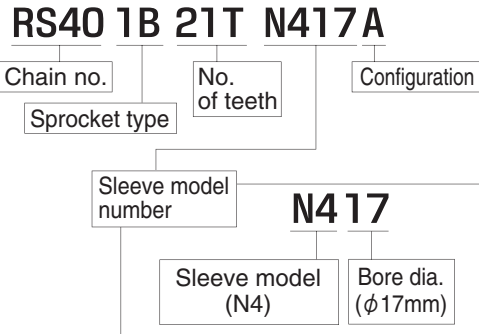

■ Sleeve Mounting Configuration

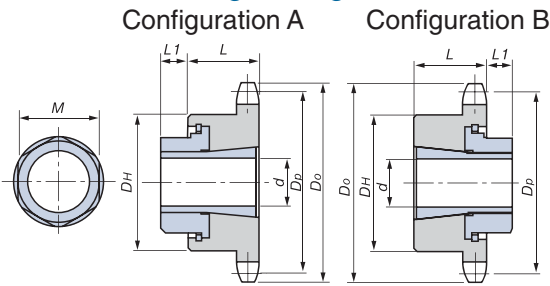

■ RS35 Lock Series N Type

● Applicable chain pitch : 9.525mm ● Roller dia : 5.08mm
 All models feature hardened teeth.

No. of Teeth	Basic Dimensions		Hub		Bore dia. d Max. Allowable Transmission Torque (N·m)	7	8	9	10	11	12	14	15	16	17	18	19	
	Pitch Circle Dia. D_p	Outer Dia. D_o	Dia. D_H	Length L		23	26	29	42	46	50	104	111	119	161	171	180	
12	36.80	41	31	20	Suitable sleeve model and dimensions	※	※	※										
13	39.80	44	32	20														
14	42.80	47	30	20		N1XX												
15	45.81	51	35	20														
16	48.82	54	37	20														
17	51.84	57	41	20														
18	54.85	60	44	20														
19	57.87	63	47	20														
20	60.89	66	50	20														
21	63.91	69	53	20														
22	66.93	72	53	20														
23	69.95	75	53	20														
24	72.97	78	53	22														
25	76.00	81	53	22														
26	79.02	84	53	22														
27	82.05	87	53	22														
28	85.07	90	53	22														
30	91.12	96	53	22														
32	97.18	102	53	22														
34	103.23	109	53	22														
35	106.26	112	53	22														
36	109.29	115	53	22														
38	115.34	121	63	25														
40	121.40	127	63	25														
												N3XX						
																N4XX		

Models with 12T and asterisks * indicate that only configuration A is available.

● Understanding the table (Ex.) RS35 chain, Required no. of teeth: 15, Required bore dia.: 11mm
 Use an N211 sleeve. "XX" in the table refers to bore diameter. Maximum transmission torque will be 46N·m.

RS35 – RS60 Lock Series (N Type)

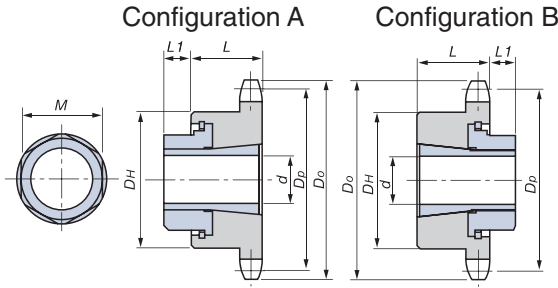

Lock Series N Type dimensions

Sleeve Model	Sleeve Protrusion L1	Nut Width Across Flats (M x S)	Nut Tightening Torque (N·m)
N1	5	18	18
N2	6	22	28
N3	8	30	65
N4	10	36	100
N5	11	41	130
N6	11	46	200

RS40 Lock Series N Type

●Applicable chain pitch : 12.7mm ●Roller dia : 7.92mm
All models feature hardened teeth.

No. of Teeth	Basic Dimensions		Hub		Bore dia. d Max. Allowable Transmission Torque (N·m)	10	11	12	14	15	16	17	18	19	20	22	24	
	Pitch Circle Dia. Dp	Outer Dia. Do	Dia. DH	Length L		42	46	50	104	111	119	161	171	180	214	236	257	
11	45.08	51	37	22	Suitable sleeve model and dimensions	**	**	**										
12	49.07	55	40	22		N2XX												
13	53.07	59	37	22														
14	57.07	63	42	22														
15	61.08	67	46	22														
16	65.10	71	50	22														
17	69.12	76	54	22														
18	73.14	80	57	22														
19	77.16	84	62	22														
20	81.18	88	67	25														
21	85.21	92	71	25														
22	89.24	96	75	25														
23	93.27	100	77	25														
24	97.30	104	63	25														
25	101.33	108	63	25														
26	105.36	112	63	25														
27	109.40	116	63	25														
28	113.43	120	63	25														
30	121.50	128	63	25														
32	129.57	137	68	28														
34	137.64	145	68	28														
35	141.68	149	68	28														
36	145.72	153	68	28														
38	153.79	161	68	28														
40	161.87	169	68	28														

Models with 11 and 12T and asterisks * indicate that only configuration A is available.

RS50 Lock Series N Type

●Applicable chain pitch : 15.875mm ●Roller dia : 10.16mm
All models feature hardened teeth.

No. of Teeth	Basic Dimensions		Hub		Bore dia. d Max. Allowable Transmission Torque (N·m)	14	15	16	17	18	19	20	22	24
	Pitch Circle Dia. Dp	Outer Dia. Do	Dia. DH	Length L		104	111	119	161	171	180	214	236	257
11	56.35	64	46	25	Suitable sleeve model and dimensions	**	**	**						
12	61.34	69	51	25		N3XX								
13	66.33	74	51	25										
14	71.34	79	52	25										
15	76.35	84	57	25										
16	81.37	89	62	25										
17	86.39	94	67	25										
18	91.42	100	72	28										
19	96.45	105	73	28										
20	101.48	110	73	28										
21	106.51	115	73	28										
22	111.55	120	73	28										
23	116.59	125	73	28										
24	121.62	130	73	28										
25	126.66	135	73	28										

Models with 11, 12, and 13T and asterisks * indicate that only configuration A is available.

RS60 Lock Series N Type

●Applicable chain pitch : 19.05mm ●Roller dia : 11.91mm
All models feature hardened teeth.

No. of Teeth	Basic Dimensions		Hub		Bore dia. d Max. Allowable Transmission Torque (N·m)	14	15	16	17	18	19	20	22	24	25	26	28
	Pitch Circle Dia. Dp	Outer Dia. Do	Dia. DH	Length L		104	111	119	161	171	180	214	236	257	370	385	415
9	55.70	64	43	32	Suitable sleeve model and dimensions	**	**	**									
10	61.65	70	49	32		N3XX											
11	67.62	76	51	32													
12	73.60	83	51	32													
13	79.60	89	57	32													
14	85.61	95	62	32													
15	91.63	101	68	32													
16	97.65	107	73	32													
17	103.67	113	73	32													
18	109.70	119	83	40													
19	115.74	126	83	40													
20	121.78	132	83	40													
21	127.82	138	83	40													
22	133.86	144	83	40													
23	139.90	150	83	40													
24	145.95	156	83	40													
25	151.99	162	83	40													

Models with 9, 10, and 11T and asterisks * indicate that only configuration A is available.

RS Sprocket Corrosion Resistant Series

Includes our stainless steel pilot bore series with excellent corrosion resistance and our engineering plastic series that can be operated with no lubrication. *See pg. 189 for a table of corrosion resistance.



Stainless steel pilot bore series

Uses stainless steel for excellent corrosion resistance. These sprockets are also highly heat and cold resistant and can be used in special environments as well. Tsubaki has a stock of single-strand 1B type sprockets (single-hub type) for RS11 – RS80 chain sizes.

Engineering plastic pilot bore series

Made of special MC901 nylon (dark blue), these sprockets can be operated without lubrication. Chain speed should not exceed 70m/min, but chain speeds up to 150m/min are possible with additional lubrication. Tsubaki has a limited stock of single-strand 1B type sprockets (single-hub type) for RS35 – RS60 chain sizes.

Ordering Standard Pilot Bore Series Sprockets

Please indicate product code and model number on your order.

Ordering Example

Stainless steel

Product Code	Model No.	Quantity	Unit
G140001	RS25-1B10T-SS	10	(pcs)

Engineering plastic

Product Code	Model No.	Quantity	Unit
G140157	RS35-1B13T-P	10	(pcs)

Model Numbering Example

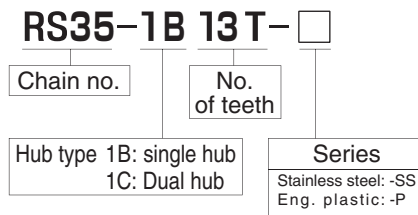

RS11 (Corrosion Resistant Stainless Steel)

See pg. 79 for Tsubaki's corrosion resistant chain series

RS11 1B Type with stainless steel pilot bore

Applicable chain pitch: 3.7465mm Roller dia.: 2.285mm

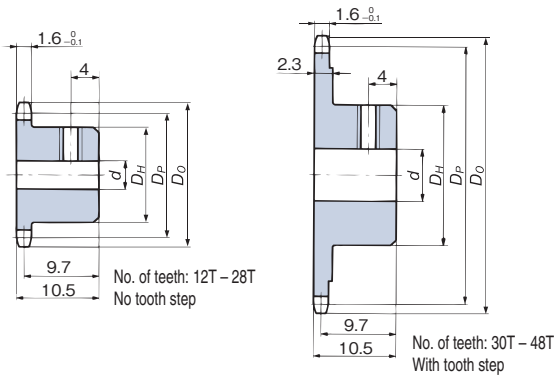

RS11 1C Type with stainless steel pilot bore

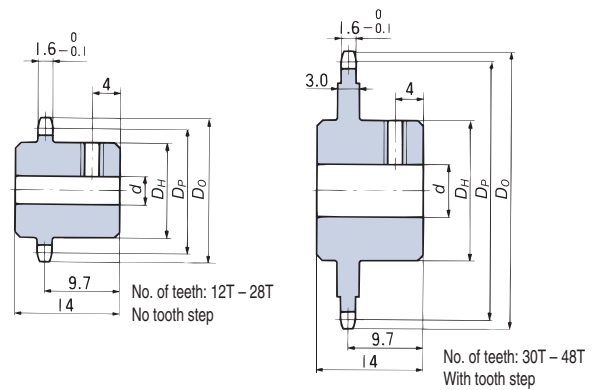

(Be aware that no set screws are provided.)

Model No.	No. of Teeth	Pitch Circle Dia. D_p	(Outer Dia.) (D_o)	Bore Dia. d		Hub Dia. D_H	Set Screw Hole	1B Approx. Mass (g)	1C Approx. Mass (g)
				Pilot bore	Max.				
RS11-1 ■12T-SS	12	14.475	16.2	4	6	9.4	M3×0.5	5.9	7.4
RS11-1 ■15T-SS	15	18.020	19.9	4	9	13		11.5	14.7
RS11-1 ■16T-SS	16	19.204	21.1	4	9	14		13.5	17.3
RS11-1 ■18T-SS	18	21.575	23.5	4	11	16		17.7	22.8
RS11-1 ■20T-SS	20	23.949	25.9	6	13	19		23.3	30.8
RS11-1 ■24T-SS	24	28.703	30.7	6	13	19		25.7	32.7
RS11-1 ■28T-SS	28	33.462	35.5	6	13	19	28.7	35.7	
RS11-1 ■30T-SS	30	35.842	37.9	6	13	19	M4×0.7	29.7	39.3
RS11-1 ■34T-SS	34	40.604	42.7	6	13	19		37.9	48.9
RS11-1 ■36T-SS	36	42.986	45.1	6	13	19		40.7	52.4
RS11-1 ■40T-SS	40	47.751	49.8	6	13	19		46.5	59.9
RS11-1 ■48T-SS	48	57.283	59.4	6	13	19		60.5	77.8

Material/Specifications

Machined stainless steel

Indicate type (B or C) in the ■ in the table above.

Contact a Tsubaki representative regarding numbers of teeth other than those above.

Note: Max. shaft bore diameter shown is for general situations. Please decide or confirm shaft bore diameter and key contact stress based on general machine design.

Before Use Standard Roller Chains Lube-Free Roller Chains Heavy Duty Roller Chains Corrosion Resistant Roller Chains Specialty Roller Chains Sprockets Pin Gear Drives Accessories Selection Handling

RS25 · RS35 (Corrosion Resistant Stainless Steel)

RS25 1B Type with stainless steel pilot bore

Applicable chain pitch: 6.35mm Roller dia.: 3.3mm

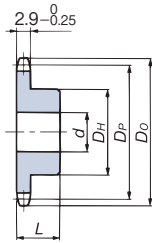

RS35 1B Type with stainless steel pilot bore

Applicable chain pitch: 9.525mm Roller dia.: 5.08mm

Hub with groove (10T – 13T)

Hub without groove (14T and over)

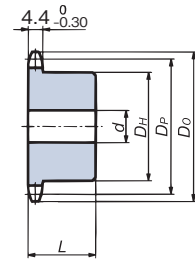
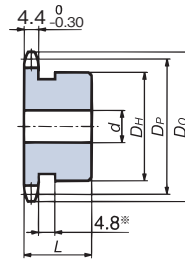

No. of teeth	Hub dia.	Groove dia.
10T	: φ 25	: φ 18
11T	: φ 27	: φ 22
12T	: φ 31	: φ 24
13T	: φ 32	: φ 28

*The groove is provided on the hub perimeter to prevent sprocket – chain interference.

RS25 1B Type with stainless steel pilot bore

Model No.	No. of Teeth	Pitch Circle Dia. D_P	(Outer Dia.) (D_o)	Bore Dia. d		Hub Dia.		Approx. Mass (kg)
				Pilot bore	Max.	Pilot bore D_H	Max. L	
RS25-1B10T-SS	10	20.55	23	6	9	14	15	0.02
RS25-1B11T-SS	11	22.54	25	6	10	16	15	0.03
RS25-1B12T-SS	12	24.53	28	6	11	18	15	0.04
RS25-1B13T-SS	13	26.53	30	6	12	20	15	0.05
RS25-1B14T-SS	14	28.54	32	6	12	20	15	0.06
RS25-1B15T-SS	15	30.54	34	6	12	20	20	0.07
RS25-1B16T-SS	16	32.55	36	8	15	25	20	0.08
RS25-1B17T-SS	17	34.56	38	8	15	25	20	0.09
RS25-1B18T-SS	18	36.57	40	8	15	25	20	0.10
RS25-1B19T-SS	19	38.58	42	8	15	25	20	0.10
RS25-1B20T-SS	20	40.59	44	8	15	25	20	0.10
RS25-1B21T-SS	21	42.61	46	10	18	30	20	0.12
RS25-1B22T-SS	22	44.62	48	10	18	30	20	0.13
RS25-1B23T-SS	23	46.63	50	10	18	30	20	0.13
RS25-1B24T-SS	24	48.65	52	10	21	35	20	0.15
RS25-1B25T-SS	25	50.66	54	10	21	35	20	0.16
RS25-1B26T-SS	26	52.68	56	10	25	40	20	0.17
RS25-1B27T-SS	27	54.70	58	10	25	40	20	0.20
RS25-1B28T-SS	28	56.71	60	10	25	40	20	0.21
RS25-1B30T-SS	30	60.75	64	12	28	45	20	0.23
RS25-1B32T-SS	32	64.78	68	12	31	50	20	0.40
RS25-1B34T-SS	34	68.82	72	12	31	50	20	0.41
RS25-1B35T-SS	35	70.84	74	12	31	50	20	0.41
RS25-1B36T-SS	36	72.86	76	12	31	50	20	0.42
RS25-1B38T-SS	38	76.90	80	12	31	50	22	0.43
RS25-1B40T-SS	40	80.93	84	12	31	50	22	0.45

Material/Specifications: Machined stainless steel

RS35 1B Type with stainless steel pilot bore

Model No.	No. of Teeth	Pitch Circle Dia. D_P	(Outer Dia.) (D_o)	Bore Dia. d		Hub Dia.		Approx. Mass (kg)
				Pilot bore	Max.	Pilot bore D_H	Max. L	
RS35-1B10T-SS	10	30.82	35	8	12	25	20	0.08
RS35-1B11T-SS	11	33.81	38	8	14	27	20	0.09
RS35-1B12T-SS	12	36.80	41	8	16.5	31	20	0.12
RS35-1B13T-SS	13	39.80	44	9.5	18	32	20	0.12
RS35-1B14T-SS	14	42.80	47	9.5	16.5	30	20	0.12
RS35-1B15T-SS	15	45.81	51	9.5	19	35	20	0.16
RS35-1B16T-SS	16	48.82	54	9.5	20	37	20	0.19
RS35-1B17T-SS	17	51.84	57	9.5	24	41	20	0.22
RS35-1B18T-SS	18	54.85	60	9.5	24.5	44	20	0.25
RS35-1B19T-SS	19	57.87	63	9.5	28.5	47	20	0.28
RS35-1B20T-SS	20	60.89	66	9.5	30	50	20	0.32
RS35-1B21T-SS	21	63.91	69	9.5	32	53	20	0.36
RS35-1B22T-SS	22	66.93	72	9.5	32	53	20	0.37
RS35-1B23T-SS	23	69.95	75	9.5	32	53	20	0.40
RS35-1B24T-SS	24	72.97	78	9.5	32	53	22	0.43
RS35-1B25T-SS	25	76.00	81	12.7	32	53	22	0.44
RS35-1B26T-SS	26	79.02	84	12.7	32	53	22	0.45
RS35-1B27T-SS	27	82.05	87	12.7	32	53	22	0.46
RS35-1B28T-SS	28	85.07	90	12.7	32	53	22	0.48
RS35-1B30T-SS	30	91.12	96	12.7	32	53	22	0.51
RS35-1B32T-SS	32	97.18	102	12.7	32	53	22	0.54
RS35-1B34T-SS	34	103.23	109	12.7	32	53	22	0.57
RS35-1B35T-SS	35	106.26	112	12.7	32	53	22	0.59
RS35-1B36T-SS	36	109.29	115	12.7	32	53	22	0.61
RS35-1B38T-SS	38	115.34	121	13	42	63	25	0.82
RS35-1B40T-SS	40	121.40	127	13	42	63	25	0.85

Material/Specifications: Machined stainless steel

Contact a Tsubaki representative regarding numbers of teeth other than those above.

Contact a Tsubaki representative regarding numbers of teeth other than those above.

RS40 · RS50 (Corrosion Resistant Stainless Steel)

RS40 1B Type with stainless steel pilot bore

Applicable chain pitch: 12.70mm Roller dia.: 7.92mm

Hub with groove (10T – 12T)

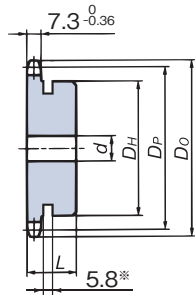

Hub without groove (13T and over)

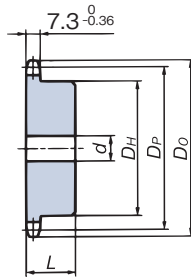

No. of teeth	Hub dia.	Groove dia.
10T	φ 32	φ 25
11T	φ 37	φ 30
12T	φ 40	φ 32

*The groove is provided on the hub perimeter to prevent sprocket – chain interference.

RS50 1B Type with stainless steel pilot bore

Applicable chain pitch: 15.875mm Roller dia.: 10.16mm

Hub with groove (10T – 13T)

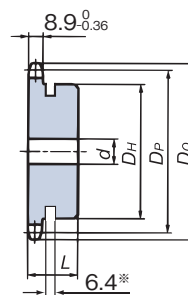

Hub without groove (14T – 40T)

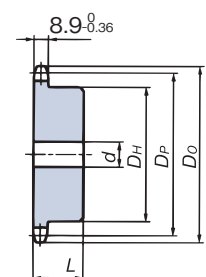

No. of teeth	Hub dia.	Groove dia.
10T	φ 40	φ 32
11T	φ 46	φ 37
12T	φ 51	φ 42
13T	φ 51	φ 47

*The groove is provided on the hub perimeter to prevent sprocket – chain interference.

RS40 1B Type with stainless steel pilot bore

Model No.	No. of Teeth	Pitch Circle Dia. D_P	Outer Dia. (D_O)	Bore Dia. d		Hub Dia.		Approx. Mass (kg)
				Pilot bore	Max.	Pilot bore D_H	Max. L	
RS40-1B10T-SS	10	41.10	47	9.5	16.5	32	22	0.14
RS40-1B11T-SS	11	45.08	51	9.5	20	37	22	0.19
RS40-1B12T-SS	12	49.07	55	9.5	22	40	22	0.22
RS40-1B13T-SS	13	53.07	59	9.5	20	37	22	0.23
RS40-1B14T-SS	14	57.07	63	9.5	24	42	22	0.28
RS40-1B15T-SS	15	61.08	67	9.5	28.5	46	22	0.34
RS40-1B16T-SS	16	65.10	71	12.7	30	50	22	0.40
RS40-1B17T-SS	17	69.12	76	12.7	32	54	22	0.46
RS40-1B18T-SS	18	73.14	80	12.7	35	57	22	0.51
RS40-1B19T-SS	19	77.16	84	12.7	39.5	62	22	0.59
RS40-1B20T-SS	20	81.18	88	12.7	45.5	67	25	0.76
RS40-1B21T-SS	21	85.21	92	12.7	45.5	71	25	0.85
RS40-1B22T-SS	22	89.24	96	12.7	50	75	25	0.95
RS40-1B23T-SS	23	93.27	100	12.7	50	77	25	1.0
RS40-1B24T-SS	24	97.30	104	12.7	42	63	25	0.84
RS40-1B25T-SS	25	101.33	108	12.7	42	63	25	0.88
RS40-1B26T-SS	26	105.36	112	12.7	42	63	25	0.92
RS40-1B27T-SS	27	109.40	116	12.7	42	63	25	0.96
RS40-1B28T-SS	28	113.43	120	12.7	42	63	25	1.0
RS40-1B30T-SS	30	121.50	128	12.7	42	63	25	1.1
RS40-1B32T-SS	32	129.57	137	16	45	68	28	1.3
RS40-1B34T-SS	34	137.64	145	16	45	68	28	1.3
RS40-1B35T-SS	35	141.68	149	16	45	68	28	1.4
RS40-1B36T-SS	36	145.72	153	16	45	68	28	1.4
RS40-1B38T-SS	38	153.79	161	16	45	68	28	1.5
RS40-1B40T-SS	40	161.87	169	16	45	68	28	1.6

Material/Specifications Machined stainless steel

Contact a Tsubaki representative regarding numbers of teeth other than those above.

RS50 1B Type with stainless steel pilot bore

Model No.	No. of Teeth	Pitch Circle Dia. D_P	Outer Dia. (D_O)	Bore Dia. d		Hub Dia.		Approx. Mass (kg)
				Pilot bore	Max.	Pilot bore D_H	Max. L	
RS50-1B10T-SS	10	51.37	58	9.5	22	40	25	0.27
RS50-1B11T-SS	11	56.35	64	12.7	25	46	25	0.33
RS50-1B12T-SS	12	61.34	69	12.7	32	51	25	0.41
RS50-1B13T-SS	13	66.33	74	12.7	32	51	25	0.46
RS50-1B14T-SS	14	71.34	79	12.7	32	52	25	0.52
RS50-1B15T-SS	15	76.35	84	12.7	35	57	25	0.62
RS50-1B16T-SS	16	81.37	89	12.7	40	62	25	0.72
RS50-1B17T-SS	17	86.39	94	12.7	45.5	67	25	0.83
RS50-1B18T-SS	18	91.42	100	12.7	47.5	72	28	1.0
RS50-1B19T-SS	19	96.45	105	12.7	47.5	73	28	1.1
RS50-1B20T-SS	20	101.48	110	12.7	47.5	73	28	1.2
RS50-1B21T-SS	21	106.51	115	15.9	47.5	73	28	1.2
RS50-1B22T-SS	22	111.55	120	15.9	47.5	73	28	1.3
RS50-1B23T-SS	23	116.59	125	15.9	47.5	73	28	1.3
RS50-1B24T-SS	24	121.62	130	15.9	47.5	73	28	1.4
RS50-1B25T-SS	25	126.66	135	15.9	47.5	73	28	1.5
RS50-1B26T-SS	26	131.70	140	18	48	73	28	1.5
RS50-1B27T-SS	27	136.74	145	18	48	73	28	1.5
RS50-1B28T-SS	28	141.79	150	18	48	73	28	1.6
RS50-1B30T-SS	30	151.87	161	18	48	73	28	1.8
RS50-1B32T-SS	32	161.96	171	18	48	73	28	1.9
RS50-1B34T-SS	34	172.05	181	18	48	73	28	2.1
RS50-1B35T-SS	35	177.10	186	18	48	73	28	2.2
RS50-1B36T-SS	36	182.15	191	23	55	83	35	2.7
RS50-1B38T-SS	38	192.24	201	23	55	83	35	2.9
RS50-1B40T-SS	40	202.33	211	23	55	83	35	3.1

Material/Specifications Machined stainless steel

Contact a Tsubaki representative regarding numbers of teeth other than those above.

RS60 · RS80 (Corrosion Resistant Stainless Steel)

RS60 1B Type with stainless steel pilot bore

Applicable chain pitch: 19.05mm Roller dia.: 11.91mm

RS80 1B Type with stainless steel pilot bore

Applicable chain pitch: 25.40mm Roller dia.: 15.88mm

Hub with groove (10T – 11T)

Hub without groove (12T – 30T)

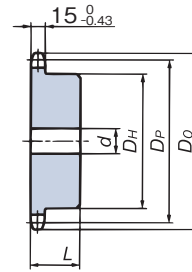
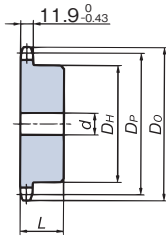
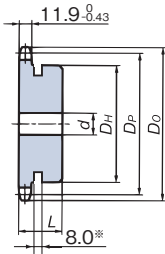

No. of teeth	Hub dia.	Groove dia.
10T	φ 49	φ 37
11T	φ 51	φ 45

*The groove is provided on the hub perimeter to prevent sprocket – chain interference.

RS60 1B Type with stainless steel pilot bore

Model No.	No. of Teeth	Pitch Circle Dia. D_P	Outer Dia. (D_0)	Bore Dia. d		Hub Dia.		Approx. Mass (kg)
				Pilot bore	Max.	Pilot bore D_H	Max. L	
RS60-1B10T-SS	10	61.65	70	12.7	30	49	32	0.49
RS60-1B11T-SS	11	67.62	76	12.7	32	51	32	0.60
RS60-1B12T-SS	12	73.60	83	12.7	32	51	32	0.69
RS60-1B13T-SS	13	79.60	89	15.9	35	57	32	0.81
RS60-1B14T-SS	14	85.61	95	15.9	39.5	62	32	0.96
RS60-1B15T-SS	15	91.63	101	15.9	45.5	68	32	1.1
RS60-1B16T-SS	16	97.65	107	15.9	47.5	73	32	1.3
RS60-1B17T-SS	17	103.67	113	15.9	47.5	73	32	1.4
RS60-1B18T-SS	18	109.70	119	15.9	55	83	40	2.0
RS60-1B19T-SS	19	115.74	126	15.9	55	83	40	2.1
RS60-1B20T-SS	20	121.78	132	15.9	55	83	40	2.2
RS60-1B21T-SS	21	127.82	138	15.9	55	83	40	2.3
RS60-1B22T-SS	22	133.86	144	15.9	55	83	40	2.5
RS60-1B23T-SS	23	139.90	150	18	55	83	40	2.5
RS60-1B24T-SS	24	145.95	156	18	55	83	40	2.6
RS60-1B25T-SS	25	151.99	162	18	55	83	40	2.7
RS60-1B26T-SS	26	158.04	168	18	55	83	40	2.9
RS60-1B27T-SS	27	164.09	174	18	55	83	40	3.0
RS60-1B28T-SS	28	170.14	180	18	55	83	40	3.1
RS60-1B30T-SS	30	182.25	193	18	55	83	40	3.4

Material/Specifications: Machined stainless steel

Contact a Tsubaki representative regarding numbers of teeth other than those above.

RS80 1B Type with stainless steel pilot bore

Model No.	No. of Teeth	Pitch Circle Dia. D_P	Outer Dia. (D_0)	Bore Dia. d		Hub Dia.		Approx. Mass (kg)
				Pilot bore	Max.	Pilot bore D_H	Max. L	
RS80-1B10T-SS	10	82.20	93	15.9	32	52	40	0.97
RS80-1B11T-SS	11	90.16	102	15.9	38	60	40	1.2
RS80-1B12T-SS	12	98.14	110	19	45	67	40	1.5
RS80-1B13T-SS	13	106.14	118	19	50	77	40	1.9
RS80-1B14T-SS	14	114.15	127	19	50	77	40	2.0
RS80-1B15T-SS	15	122.17	135	19	63	93	40	2.6
RS80-1B16T-SS	16	130.20	143	19	63	93	40	2.8
RS80-1B17T-SS	17	138.23	151	19	63	93	40	3.0
RS80-1B18T-SS	18	146.27	159	19	63	93	40	3.2
RS80-1B19T-SS	19	154.32	167	23	63	93	40	3.4
RS80-1B20T-SS	20	162.37	176	23	63	93	40	3.6
RS80-1B21T-SS	21	170.42	184	23	63	93	40	3.8
RS80-1B22T-SS	22	178.48	192	28	75	107	45	4.8
RS80-1B23T-SS	23	186.54	200	28	75	107	45	5.1
RS80-1B24T-SS	24	194.60	208	28	75	107	45	5.4
RS80-1B25T-SS	25	202.66	216	28	75	107	45	5.6

Material/Specifications: Machined stainless steel

Contact a Tsubaki representative regarding numbers of teeth other than those above.

RS35 – RS60 (Corrosion Resistant Engineering Plastic)

Corrosion Resistant Engineering Plastic Pilot Bore Series

Operating Conditions

Operating temperature : -10°C to 60°C

Permissible speed : Recommended at a circumferential speed of 70m/min or below (lube-free operation)
(Can be used up to 150m/min in lubed or pre-lubed operation.)

Material : Special MC901 nylon (dark blue)



RS35 Engineering plastic pilot bore sprocket

Hub with groove (13T)

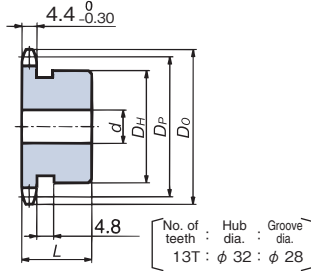

Hub without groove (14T and over)

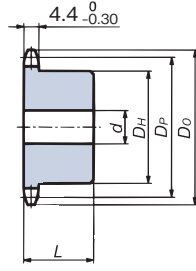

Model No.	No. of Teeth	Allowable Transmission Torque N · m	Pitch Circle Dia. D _P	(Outer Dia.) (D _O)	Bore Dia. d		Hub Dia.		Approx. Mass (kg)
					Pilot bore	Max.	Pilot bore D _H	Max. L	
RS35-1B13T-P	13	5.30	39.80	44	9.5	14	32	20	0.02
RS35-1B14T-P	14	5.69	42.80	46	9.5	15	30	20	0.02
RS35-1B15T-P	15	6.08	45.81	51	9.5	17	35	20	0.02
RS35-1B16T-P	16	6.47	48.82	53	9.5	19	37	20	0.03
RS35-1B17T-P	17	6.86	51.84	57	9.5	22	41	20	0.03
RS35-1B18T-P	18	7.26	54.85	60	12.7	22	44	20	0.04
RS35-1B20T-P	20	8.04	60.89	66	12.7	27	50	20	0.05
RS35-1B22T-P	22	8.83	66.93	72	12.7	28	53	20	0.06
RS35-1B24T-P	24	9.71	72.97	78	12.7	32	53	22	0.08
RS35-1B25T-P	25	10.1	76.00	81	12.7	32	53	22	0.08
RS35-1B26T-P	26	10.5	79.02	83	12.7	35	53	22	0.09
RS35-1B28T-P	28	11.3	85.07	90	12.7	40	53	22	0.10
RS35-1B30T-P	30	12.1	91.12	96	12.7	42	53	22	0.12

RS40 Engineering plastic pilot bore sprocket

Hub with groove (12T)

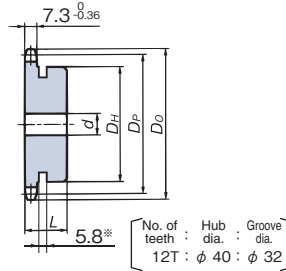

Hub without groove (13T and over)

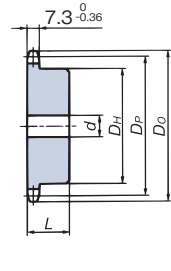

Model No.	No. of Teeth	Allowable Transmission Torque N · m	Pitch Circle Dia. D _P	(Outer Dia.) (D _O)	Bore Dia. d		Hub Dia.		Approx. Mass (kg)
					Pilot bore	Max.	Pilot bore D _H	Max. L	
RS40-1B12T-P	12	10.8	49.07	53	9.5	16	40	22	0.03
RS40-1B13T-P	13	11.7	53.07	58	12.7	18	37	22	0.04
RS40-1B14T-P	14	12.6	57.07	63	12.7	22	42	22	0.04
RS40-1B15T-P	15	13.4	61.08	67	12.7	25	46	22	0.05
RS40-1B16T-P	16	14.3	65.10	71	12.7	27	50	22	0.06
RS40-1B17T-P	17	15.3	69.12	75	12.7	28	54	22	0.07
RS40-1B18T-P	18	16.2	73.14	78	12.7	30	57	22	0.08
RS40-1B20T-P	20	17.9	81.18	88	12.7	35	67	25	0.11
RS40-1B22T-P	22	19.6	89.24	96	12.7	42	75	25	0.14
RS40-1B24T-P	24	21.5	97.30	104	12.7	50	80	25	0.16
RS40-1B25T-P	25	22.4	101.33	108	12.7	50	80	25	0.17
RS40-1B26T-P	26	23.2	105.36	112	12.7	52	85	25	0.18
RS40-1B28T-P	28	25.0	113.43	120	12.7	55	90	25	0.21
RS40-1B30T-P	30	26.8	121.50	128	12.7	60	100	25	0.26

RS50 Engineering plastic pilot bore sprocket

Hub with groove (13T)

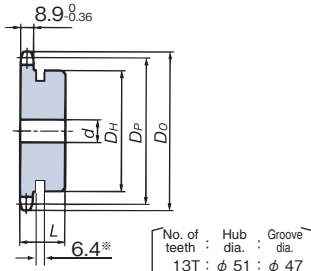

Hub without groove (14T and over)

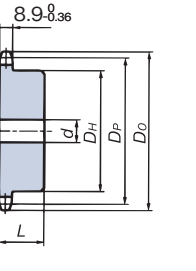

Model No.	No. of Teeth	Allowable Transmission Torque N · m	Pitch Circle Dia. D _P	(Outer Dia.) (D _O)	Bore Dia. d		Hub Dia.		Approx. Mass (kg)
					Pilot bore	Max.	Pilot bore D _H	Max. L	
RS50-1B13T-P	13	22.8	66.34	73	12.7	25	51	25	0.07
RS50-1B14T-P	14	24.5	71.34	78	12.7	28	52	25	0.08
RS50-1B15T-P	15	26.2	76.35	83	12.7	30	57	25	0.09
RS50-1B16T-P	16	27.9	81.37	89	12.7	32	62	25	0.11
RS50-1B17T-P	17	29.6	86.39	93	12.7	35	67	25	0.12
RS50-1B18T-P	18	31.4	91.42	98	12.7	40	72	28	0.15
RS50-1B20T-P	20	34.8	101.48	110	15.9	50	80	28	0.20
RS50-1B22T-P	22	38.2	111.55	120	15.9	55	90	28	0.24
RS50-1B24T-P	24	41.8	121.62	130	15.9	60	100	28	0.29
RS50-1B25T-P	25	43.4	126.66	135	15.9	60	100	28	0.31
RS50-1B26T-P	26	45.2	131.70	140	18	65	110	28	0.34
RS50-1B28T-P	28	48.6	141.79	150	18	70	120	28	0.40
RS50-1B30T-P	30	52.2	151.87	161	18	70	120	28	0.43

RS60 Engineering plastic pilot bore sprocket

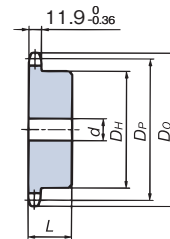

Model No.	No. of Teeth	Allowable Transmission Torque N · m	Pitch Circle Dia. D _P	(Outer Dia.) (D _O)	Bore Dia. d		Hub Dia.		Approx. Mass (kg)
					Pilot bore	Max.	Pilot bore D _H	Max. L	
RS60-1B13T-P	13	41.0	79.60	88	15.9	30	57	32	0.12
RS60-1B14T-P	14	44.1	85.61	93	15.9	32	62	32	0.14
RS60-1B15T-P	15	47.2	91.62	99	15.9	35	68	32	0.16
RS60-1B16T-P	16	50.3	97.65	107	15.9	42	73	32	0.19
RS60-1B17T-P	17	53.3	103.67	113	15.9	50	80	32	0.21
RS60-1B18T-P	18	56.5	109.71	119	15.9	52	85	40	0.30
RS60-1B20T-P	20	62.7	121.78	132	15.9	60	95	40	0.38
RS60-1B22T-P	22	68.9	133.86	144	15.9	65	110	40	0.51
RS60-1B24T-P	24	75.1	145.95	156	18	70	120	40	0.57
RS60-1B25T-P	25	78.3	151.99	162	18	70	120	40	0.59
RS60-1B26T-P	26	81.4	158.04	168	18	70	120	40	0.62
RS60-1B28T-P	28	87.6	170.14	180	18	70	120	40	0.65
RS60-1B30T-P	30	93.8	182.25	193	18	70	120	40	0.70

Bold lettering indicates stock items.

Before Use
 Standard Roller Chains
 Lube-Free Roller Chains
 Heavy Duty Roller Chains
 Corrosion Resistant Roller Chains
 Specialty Roller Chains
 Sprockets
 Pin Gear Drives
 Accessories
 Selection
 Handling

RS Sprocket Corrosion Resistant Fit Bore® Series



■ Stainless steel fit bore sprockets

Applicable models: RS25 – RS80 1B Type stainless steel sprockets

Each model is provided with a finished bore, keyway, and two set screws (RS25 has no keyway and only one set screw).

Can be used as is without additional machining.

Applicable bore processing specifications

Applicable bore dia. : 06 – 65mm Keyway specifications : New JIS standards (JIS B 1301 – 1996), normal type parallel key
 Bore tolerance : H7 Keyway tolerance : Js9
 (RS25 has a bore tolerance of H8 with no keyway)

Ordering Corrosion Resistant Stainless Steel Fit Bore Sprockets

Please indicate product code and model number on your order.

■ Ordering Example

Product Code	Model No.	Quantity	Unit
G150001	RS25-1B10T-SS-H08	10	(pcs)

■ Model Numbering Example

RS35-1B 10T-SS-H10 J

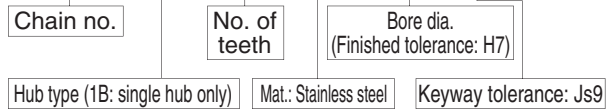

RS25 Stainless Steel Fit Bore® Sprockets

See pg. 79 for Tsubaki's corrosion resistant chain series

■ RS25 Stainless Steel Fit Bore Sprockets

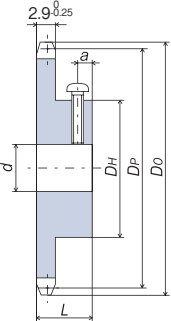

Model Numbering Example

RS25 - 1B 10T - SS - H □ □

Bore dia. : Finished tolerance of H8
 (Put a zero (0) first if the finished diameter is a single-digit value.)
 Stainless steel : SS
 No. of teeth
 Hub type (1B: Single hub only)
 Chain no.

Set screw size

Bore dia. d	Bolt size
06	M3
08~15	M4

Comes with one stainless steel round Philips head screw.

Specifications: Bore tolerance of H8 provided with no keyway and one set screw.

Model No.	No. of Teeth	Basic Dimensions		Hub		Tap position a	Finished bore dia. d Tolerance H8				
		Pitch Circle Dia. DP	(Outer Dia.) (DO)	Dia. DH	Length L		06	08	10	12	15
RS25-1B10T-SS-H□□	10	20.55	23	14	15	5	●	●			
RS25-1B11T-SS-H□□	11	22.54	25	16	15	5	●	●			
RS25-1B12T-SS-H□□	12	24.53	28	18	15	5	●	●	●		
RS25-1B13T-SS-H□□	13	26.53	30	20	15	5	●	●	●		
RS25-1B14T-SS-H□□	14	28.54	32	20	15	5	●	●	●		
RS25-1B15T-SS-H□□	15	30.54	34	20	20	7	●	●	●		
RS25-1B16T-SS-H□□	16	32.55	36	25	20	7		●	●		
RS25-1B17T-SS-H□□	17	34.56	38	25	20	7		●	●		
RS25-1B18T-SS-H□□	18	36.57	40	25	20	7		●	●		
RS25-1B19T-SS-H□□	19	38.58	42	25	20	7		●	●		
RS25-1B20T-SS-H□□	20	40.59	44	25	20	7		●	●		
RS25-1B21T-SS-H□□	21	42.61	46	30	20	7			●	●	
RS25-1B22T-SS-H□□	22	44.62	48	30	20	7			●	●	
RS25-1B23T-SS-H□□	23	46.63	50	30	20	7			●	●	
RS25-1B24T-SS-H□□	24	48.65	52	35	20	7			●	●	
RS25-1B25T-SS-H□□	25	50.66	54	35	20	7			●	●	
RS25-1B26T-SS-H□□	26	52.68	56	40	20	7			●	●	
RS25-1B27T-SS-H□□	27	54.70	58	40	20	7			●	●	
RS25-1B28T-SS-H□□	28	56.71	60	40	20	7			●	●	
RS25-1B30T-SS-H□□	30	60.75	64	45	20	7				●	●
RS25-1B32T-SS-H□□	32	64.78	68	50	20	7				●	●

● Circles indicate permissible bore diameters.

RS35 Stainless Steel Fit Bore® Sprockets

RS35 Stainless Steel Fit Bore Sprockets

Applicable chain pitch: 9.525mm Roller dia.: 5.08mm

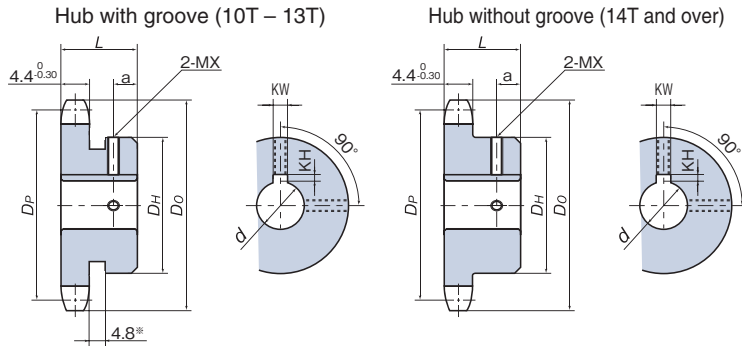

No. of teeth	Hub dia.	Groove dia.
10T	φ 25	φ 18
11T	φ 27	φ 22
12T	φ 31	φ 24
13T	φ 32	φ 28

*The groove is provided on the hub perimeter to prevent sprocket - chain interference.

Applicable Bore Dia.	Keyway Width KW	Tolerance (Js9)	Keyway Depth KH	Tolerance	Set Screw Size MX
10 and up to 12	4		1.8		M4
More than 12 and up to 17	5	±0.0150	2.3	+0.10	M5
More than 17 and up to 22	6		2.8		M6
More than 22 and up to 30	8	±0.0180	3.3		M8
More than 30 and up to 38	10		3.8	+0.20	M8
More than 38 and up to 44	12		3.8		M8
More than 44 and up to 50	14	±0.0215	4.3		M10
More than 50 and up to 58	16		4.4		M10
More than 58 and up to 65	18		4.4		M10

Provided with two stainless steel set screws.

Model Numbering Example

RS35 - 1B 20T - SS - H □ □ J

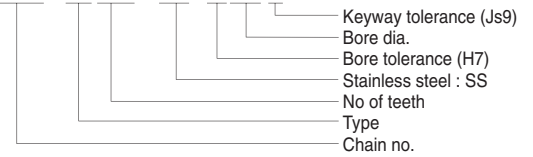

Model No.	No. of Teeth	Basic Dimensions		Hub		Tap position a	Finished bore dia. d Tolerance H7															
		Pitch Circle Dia. DP	(Outer Dia.) (DO)	Dia. DH	Length L		10	12	14	15	16	17	18	19	20	22	24	25	28	30	32	
RS35-1B10T-SS-H□□J	10	30.82	35	25	20	5	●	●														
RS35-1B11T-SS-H□□J	11	33.81	38	27	20	5	●	●	●													
RS35-1B12T-SS-H□□J	12	36.80	41	31	20	5	●	●	●	●												
RS35-1B13T-SS-H□□J	13	39.80	44	32	20	5	●	●	●	●	●											
RS35-1B14T-SS-H□□J	14	42.81	47	30	20	8	●	●	●	●	●	●										
RS35-1B15T-SS-H□□J	15	45.81	51	35	20	8	●	●	●	●	●	●	●									
RS35-1B16T-SS-H□□J	16	48.82	54	37	20	8	●	●	●	●	●	●	●	●								
RS35-1B17T-SS-H□□J	17	51.84	57	41	20	8		●	●	●	●	●	●	●	●							
RS35-1B18T-SS-H□□J	18	54.85	60	44	20	8			●	●	●	●	●	●	●	●						
RS35-1B19T-SS-H□□J	19	57.87	63	47	20	8			●	●	●	●	●	●	●	●	●					
RS35-1B20T-SS-H□□J	20	60.89	66	50	20	8			●	●	●	●	●	●	●	●	●	●				
RS35-1B21T-SS-H□□J	21	63.91	69	53	20	8				●	●	●	●	●	●	●	●	●	●			
RS35-1B22T-SS-H□□J	22	66.93	72	53	20	8				●	●	●	●	●	●	●	●	●	●	●		
RS35-1B23T-SS-H□□J	23	69.95	75	53	20	8				●	●	●	●	●	●	●	●	●	●	●	●	
RS35-1B24T-SS-H□□J	24	72.97	78	53	22	10/7**				●	●	●	●	●	●	●	○	○	○	○	○	○
RS35-1B25T-SS-H□□J	25	76.00	81	53	22	10/7**				●	●	●	●	●	●	○	○	○	○	○	○	○
RS35-1B26T-SS-H□□J	26	79.02	84	53	22	10/7**				●	●	●	●	●	○	○	○	○	○	○	○	○
RS35-1B27T-SS-H□□J	27	82.05	87	53	22	10/7**				●	●	●	●	○	○	○	○	○	○	○	○	○
RS35-1B28T-SS-H□□J	28	85.07	90	53	22	10/7**				●	●	●	○	○	○	○	○	○	○	○	○	○
RS35-1B30T-SS-H□□J	30	91.12	96	53	22	10/7**				●	●	○	○	○	○	○	○	○	○	○	○	○

● circles indicate applicable bore diameters.
○ circles indicate that the tap position is at 7mm for applicable bore diameters.

Before Use Standard Roller Chains Lube-Free Roller Chains Heavy Duty Roller Chains Corrosion Resistant Roller Chains Specialty Roller Chains Sprockets Pin Gear Drives Accessories Selection Handling

RS40 Stainless Steel Fit Bore® Sprockets

RS40 Stainless Steel Fit Bore Sprockets

Applicable chain pitch: 12.70mm Roller dia.: 7.92mm

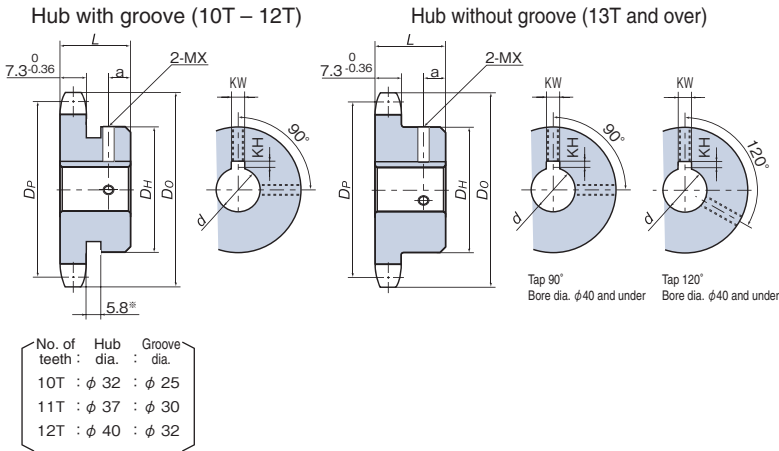

Applicable Bore Dia.	Keyway Width KW	Tolerance (Js9)	Keyway Depth KH	Tolerance	Set Screw Size MX
10 and up to 12	4		1.8		M4
More than 12 and up to 17	5	±0.0150	2.3	+0.10	M5
More than 17 and up to 22	6		2.8		M6
More than 22 and up to 30	8	±0.0180	3.3		M8
More than 30 and up to 38	10		3.8	+0.20	M8
More than 38 and up to 44	12		4.3		M10
More than 44 and up to 50	14	±0.0215	4.4		M10
More than 50 and up to 58	16				
More than 58 and up to 65	18				

Provided with two stainless steel set screws.

Model Numbering Example

RS40 - 1B 20T - SS - H □ □ J

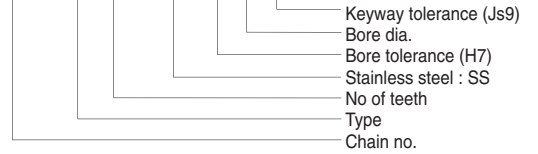

*The groove is provided on the hub perimeter to prevent sprocket – chain interference.

Model No.	No. of Teeth	Basic Dimensions		Hub		Tap position a	Finished bore dia. d Tolerance H7																				
		Pitch Circle Dia. (DP)	(Outer Dia.) (DO)	Dia. (DH)	Length (L)		10	12	14	15	16	17	18	19	20	22	24	25	28	30	32	35	38	40	42	45	48
RS40-1B10T-SS-H□□J	10	41.10	47	32	22	5	●	●	●	●	●																
RS40-1B11T-SS-H□□J	11	45.08	51	37	22	5	●	●	●	●	●	●	●														
RS40-1B12T-SS-H□□J	12	49.07	55	40	22	5	●	●	●	●	●	●	●	●													
RS40-1B13T-SS-H□□J	13	53.07	59	37	22	7			●	●	●	●	●	●	●												
RS40-1B14T-SS-H□□J	14	57.07	63	42	22	7			●	●	●	●	●	●	●	●											
RS40-1B15T-SS-H□□J	15	61.08	67	46	22	7			●	●	●	●	●	●	●	●	●										
RS40-1B16T-SS-H□□J	16	65.10	71	50	22	7			●	●	●	●	●	●	●	●	●	●									
RS40-1B17T-SS-H□□J	17	69.12	76	54	22	7			●	●	●	●	●	●	●	●	●	●	●								
RS40-1B18T-SS-H□□J	18	73.14	80	57	22	7			●	●	●	●	●	●	●	●	●	●	●	●							
RS40-1B19T-SS-H□□J	19	77.16	84	62	22	7			●	●	●	●	●	●	●	●	●	●	●	●	●						
RS40-1B20T-SS-H□□J	20	81.18	88	67	25	7			●	●	●	●	●	●	●	●	●	●	●	●	●	●					
RS40-1B21T-SS-H□□J	21	85.21	92	71	25	7			●	●	●	●	●	●	●	●	●	●	●	●	●	●	●				
RS40-1B22T-SS-H□□J	22	89.24	96	75	25	7			●	●	●	●	●	●	●	●	●	●	●	●	●	●	●	●			
RS40-1B23T-SS-H□□J	23	93.27	100	77	25	7			●	●	●	●	●	●	●	●	●	●	●	●	●	●	●	●	●		
RS40-1B24T-SS-H□□J	24	97.30	104	63	25	7			●	●	●	●	●	●	●	●	●	●	●	●	●	●	●	●	●	●	
RS40-1B25T-SS-H□□J	25	101.33	108	63	25	7			●	●	●	●	●	●	●	●	●	●	●	●	●	●	●	●	●	●	
RS40-1B26T-SS-H□□J	26	105.36	112	63	25	7			●	●	●	●	●	●	●	●	●	●	●	●	●	●	●	●	●	●	
RS40-1B27T-SS-H□□J	27	109.40	116	63	25	7			●	●	●	●	●	●	●	●	●	●	●	●	●	●	●	●	●	●	
RS40-1B28T-SS-H□□J	28	113.43	120	63	25	7			●	●	●	●	●	●	●	●	●	●	●	●	●	●	●	●	●	●	
RS40-1B30T-SS-H□□J	30	121.50	128	63	25	7			●	●	●	●	●	●	●	●	●	●	●	●	●	●	●	●	●	●	

● Circles indicate permissible bore diameters.

RS50 Stainless Steel Fit Bore® Sprockets

RS50 Stainless Steel Fit Bore Sprockets

Applicable chain pitch: 15.875mm Roller dia.: 10.16mm

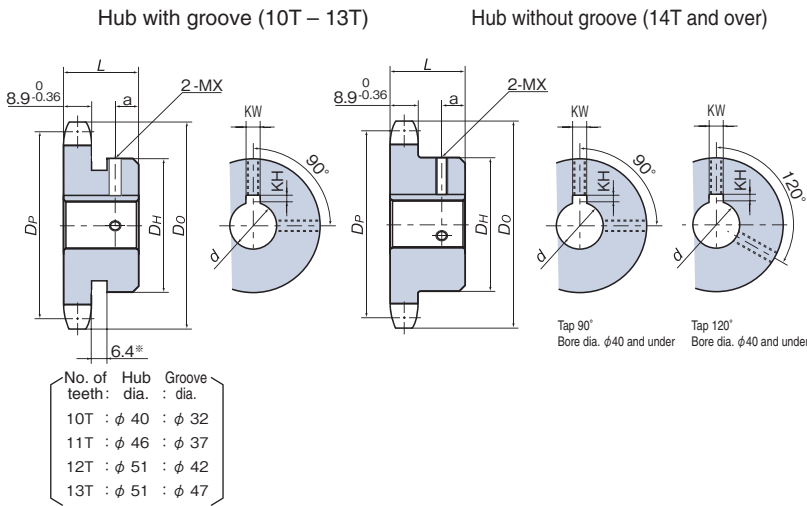

*The groove is provided on the hub perimeter to prevent sprocket – chain interference.

Applicable Bore Dia.	Keyway Width KW	Tolerance (Js9)	Keyway Depth KH	Tolerance	Set Screw Size MX
10 and up to 12	4		1.8		M4
More than 12 and up to 17	5	±0.0150	2.3	+0.1 0	M5
More than 17 and up to 22	6		2.8		M6
More than 22 and up to 30	8	±0.0180	3.3		M8
More than 30 and up to 38	10		3.8	+0.2 0	M8
More than 38 and up to 44	12		4.3		M10
More than 44 and up to 50	14	±0.0215	4.4		M10
More than 50 and up to 58	16				
More than 58 and up to 65	18				

Provided with two stainless steel set screws.

Model Numbering Example

RS50 – 1B 20T – SS – H □ □ J



Model No.	No. of Teeth	Basic Dimensions		Hub		Tap position	Finished bore dia. d Tolerance H7																							
		Pitch Circle Dia. DP	(Outer Dia.) (Do)	Dia. DH	Length L		a	10	12	14	15	16	17	18	19	20	22	24	25	28	30	32	35	38	40	42	45	48		
RS50-1B10T-SS-H□□J	10	51.37	58	40	25	6	●	●	●	●	●	●	●	●	●	●	●	●	●	●	●	●	●	●	●	●	●	●		
RS50-1B11T-SS-H□□J	11	56.35	64	46	25	6			●	●	●	●	●	●	●	●	●	●	●	●	●	●	●	●	●	●	●	●		
RS50-1B12T-SS-H□□J	12	61.34	69	51	25	6			●	●	●	●	●	●	●	●	●	●	●	●	●	●	●	●	●	●	●	●		
RS50-1B13T-SS-H□□J	13	66.34	74	51	25	6			●	●	●	●	●	●	●	●	●	●	●	●	●	●	●	●	●	●	●	●		
RS50-1B14T-SS-H□□J	14	71.34	79	52	25	7			●	●	●	●	●	●	●	●	●	●	●	●	●	●	●	●	●	●	●	●		
RS50-1B15T-SS-H□□J	15	76.35	84	57	25	7			●	●	●	●	●	●	●	●	●	●	●	●	●	●	●	●	●	●	●	●		
RS50-1B16T-SS-H□□J	16	81.37	89	62	25	7			●	●	●	●	●	●	●	●	●	●	●	●	●	●	●	●	●	●	●	●		
RS50-1B17T-SS-H□□J	17	86.39	94	67	25	7			●	●	●	●	●	●	●	●	●	●	●	●	●	●	●	●	●	●	●	●		
RS50-1B18T-SS-H□□J	18	91.41	100	72	28	8			●	●	●	●	●	●	●	●	●	●	●	●	●	●	●	●	●	●	●	●		
RS50-1B19T-SS-H□□J	19	96.45	105	73	28	8			●	●	●	●	●	●	●	●	●	●	●	●	●	●	●	●	●	●	●	●		
RS50-1B20T-SS-H□□J	20	101.48	110	73	28	8			●	●	●	●	●	●	●	●	●	●	●	●	●	●	●	●	●	●	●	●		
RS50-1B21T-SS-H□□J	21	106.51	115	73	28	8			●	●	●	●	●	●	●	●	●	●	●	●	●	●	●	●	●	●	●	●		
RS50-1B22T-SS-H□□J	22	111.55	120	73	28	8			●	●	●	●	●	●	●	●	●	●	●	●	●	●	●	●	●	●	●	●		
RS50-1B23T-SS-H□□J	23	116.58	125	73	28	8			●	●	●	●	●	●	●	●	●	●	●	●	●	●	●	●	●	●	●	●		
RS50-1B24T-SS-H□□J	24	121.62	130	73	28	8			●	●	●	●	●	●	●	●	●	●	●	●	●	●	●	●	●	●	●	●		
RS50-1B25T-SS-H□□J	25	126.66	135	73	28	8			●	●	●	●	●	●	●	●	●	●	●	●	●	●	●	●	●	●	●	●		
RS50-1B26T-SS-H□□J	26	131.70	140	73	28	8			●	●	●	●	●	●	●	●	●	●	●	●	●	●	●	●	●	●	●	●		
RS50-1B27T-SS-H□□J	27	136.74	145	73	28	8			●	●	●	●	●	●	●	●	●	●	●	●	●	●	●	●	●	●	●	●		
RS50-1B28T-SS-H□□J	28	141.79	150	73	28	8			●	●	●	●	●	●	●	●	●	●	●	●	●	●	●	●	●	●	●	●		
RS50-1B30T-SS-H□□J	30	151.87	161	73	28	8			●	●	●	●	●	●	●	●	●	●	●	●	●	●	●	●	●	●	●	●		

● circles indicate applicable bore diameters.

Before Use Standard Roller Chains Lubrication-Free Roller Chains Heavy Duty Roller Chains Corrosion Resistant Roller Chains Specialty Roller Chains Sprockets Pin Gear Drives Accessories Selection Handling

RS60 Stainless Steel Fit Bore® Sprockets

RS60 Stainless Steel Fit Bore Sprockets

Applicable chain pitch: 19.05mm Roller dia.: 11.91mm

Hub with groove (10T – 11T)

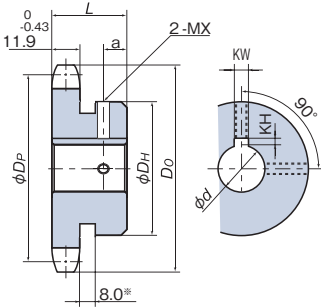

Hub without groove (12T and over)

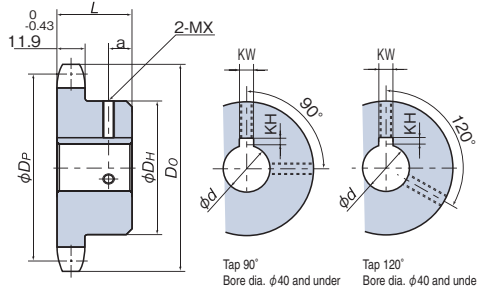

Tap 90° Bore dia. φ40 and under
Tap 120° Bore dia. φ40 and under

No. of teeth	Hub dia.	Groove dia.
10T	φ 49	φ 37
11T	φ 51	φ 45

*The groove is provided on the hub perimeter to prevent sprocket – chain interference.

Applicable Bore Dia.	Keyway Width K W	Tolerance (Js9)	Keyway Depth K H	Tolerance	Set Screw Size MX
10 and up to 12	4		1.8	+0.1 0	M4
More than 12 and up to 17	5	±0.0150	2.3		M5
More than 17 and up to 22	6		2.8	+0.2 0	M6
More than 22 and up to 30	8	±0.0180	3.3		M8
More than 30 and up to 38	10				M8
More than 38 and up to 44	12		3.8	M10	
More than 44 and up to 50	14	±0.0215			M10
More than 50 and up to 58	16		4.3		
More than 58 and up to 65	18		4.4		

Provided with two stainless steel set screws.

Model Numbering Example

RS60 – 1B 20T – SS – H □ □ J

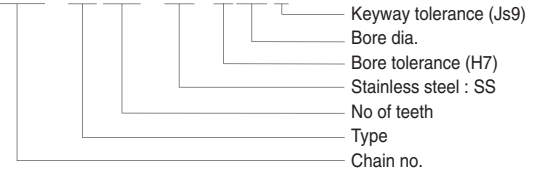

Model No.	No. of Teeth	Basic Dimensions		Hub		Tap position a	Finished bore dia. d Tolerance H7																					
		Pitch Circle Dia. DP	(Outer Dia.) (Do)	Dia. DH	Length L		14	15	16	17	18	19	20	22	24	25	28	30	32	35	38	40	42	45	48	50	55	
RS60-1B10T-SS-H□□J	10	61.65	70	49	32	6	●	●	●	●	●	●	●	●	●	●	●	●	●	●	●	●	●	●	●	●	●	●
RS60-1B11T-SS-H□□J	11	67.62	76	51	32	6	●	●	●	●	●	●	●	●	●	●	●	●	●	●	●	●	●	●	●	●	●	●
RS60-1B12T-SS-H□□J	12	73.60	83	51	32	12	●	●	●	●	●	●	●	●	●	●	●	●	●	●	●	●	●	●	●	●	●	●
RS60-1B13T-SS-H□□J	13	79.60	89	57	32	12	●	●	●	●	●	●	●	●	●	●	●	●	●	●	●	●	●	●	●	●	●	●
RS60-1B14T-SS-H□□J	14	85.61	95	62	32	12	●	●	●	●	●	●	●	●	●	●	●	●	●	●	●	●	●	●	●	●	●	●
RS60-1B15T-SS-H□□J	15	91.62	101	68	32	12	●	●	●	●	●	●	●	●	●	●	●	●	●	●	●	●	●	●	●	●	●	●
RS60-1B16T-SS-H□□J	16	97.65	107	73	32	12	●	●	●	●	●	●	●	●	●	●	●	●	●	●	●	●	●	●	●	●	●	●
RS60-1B17T-SS-H□□J	17	103.67	113	73	32	12	●	●	●	●	●	●	●	●	●	●	●	●	●	●	●	●	●	●	●	●	●	●
RS60-1B18T-SS-H□□J	18	109.71	119	83	40	12	●	●	●	●	●	●	●	●	●	●	●	●	●	●	●	●	●	●	●	●	●	●
RS60-1B19T-SS-H□□J	19	115.74	126	83	40	12	●	●	●	●	●	●	●	●	●	●	●	●	●	●	●	●	●	●	●	●	●	●
RS60-1B20T-SS-H□□J	20	121.78	132	83	40	12	●	●	●	●	●	●	●	●	●	●	●	●	●	●	●	●	●	●	●	●	●	●
RS60-1B21T-SS-H□□J	21	127.82	138	83	40	12	●	●	●	●	●	●	●	●	●	●	●	●	●	●	●	●	●	●	●	●	●	●
RS60-1B22T-SS-H□□J	22	133.86	144	83	40	12	●	●	●	●	●	●	●	●	●	●	●	●	●	●	●	●	●	●	●	●	●	●
RS60-1B23T-SS-H□□J	23	139.90	150	83	40	12	●	●	●	●	●	●	●	●	●	●	●	●	●	●	●	●	●	●	●	●	●	●
RS60-1B24T-SS-H□□J	24	145.95	156	83	40	12	●	●	●	●	●	●	●	●	●	●	●	●	●	●	●	●	●	●	●	●	●	●
RS60-1B25T-SS-H□□J	25	151.99	162	83	40	12	●	●	●	●	●	●	●	●	●	●	●	●	●	●	●	●	●	●	●	●	●	●
RS60-1B26T-SS-H□□J	26	158.04	168	83	40	12	●	●	●	●	●	●	●	●	●	●	●	●	●	●	●	●	●	●	●	●	●	●
RS60-1B27T-SS-H□□J	27	164.09	174	83	40	12	●	●	●	●	●	●	●	●	●	●	●	●	●	●	●	●	●	●	●	●	●	●
RS60-1B28T-SS-H□□J	28	170.14	180	83	40	12	●	●	●	●	●	●	●	●	●	●	●	●	●	●	●	●	●	●	●	●	●	●
RS60-1B30T-SS-H□□J	30	182.25	193	83	40	12	●	●	●	●	●	●	●	●	●	●	●	●	●	●	●	●	●	●	●	●	●	●

● Circles indicate permissible bore diameters.

Before Use
Standard Roller Chains
Lube-Free Roller Chains
Heavy Duty Roller Chains
Corrosion Resistant Roller Chains
Specialty Roller Chains
Sprockets
Pin Gear Drives
Accessories
Selection
Handling

RS80 Stainless Steel Fit Bore® Sprockets

RS80 Stainless Steel Fit Bore Sprockets

Applicable chain pitch: 25.40mm Roller dia.: 15.88mm

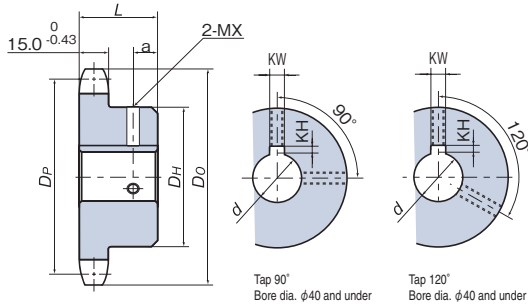

Applicable Bore Dia.	Keyway Width KW	Tolerance (Js9)	Keyway Depth KH	Tolerance	Set Screw Size MX
10 and up to 12	4		1.8		M4
More than 12 and up to 17	5	±0.0150	2.3	+0.1 0	M5
More than 17 and up to 22	6		2.8		M6
More than 22 and up to 30	8	±0.0180			
More than 30 and up to 38	10		3.3		
More than 38 and up to 44	12			+0.2 0	M8
More than 44 and up to 50	14	±0.0215	3.8		
More than 50 and up to 58	16		4.3		
More than 58 and up to 65	18		4.4		M10

Provided with two stainless steel set screws.

Model Numbering Example

RS80 - 1B 20T - SS - H □ □ J



Model No.	No. of Teeth	Basic Dimensions		Hub		Tap position a	Finished bore dia. d Tolerance H7																		
		Pitch Circle Dia. DP	(Outer Dia.) (Do)	Dia. DH	Length L		17	18	19	20	22	24	25	28	30	32	35	38	40	42	45	48	50	55	60
RS80-1B10T-SS-H□□J	10	82.20	93	52	40	12	●	●	●	●	●	●	●	●	●										
RS80-1B11T-SS-H□□J	11	90.16	102	60	40	12	●	●	●	●	●	●	●	●	●	●									
RS80-1B12T-SS-H□□J	12	98.14	110	67	40	12				●	●	●	●	●	●	●	●	●	●	●	●	●	●	●	●
RS80-1B13T-SS-H□□J	13	106.14	118	77	40	12				●	●	●	●	●	●	●	●	●	●	●	●	●	●	●	●
RS80-1B14T-SS-H□□J	14	114.15	127	77	40	12				●	●	●	●	●	●	●	●	●	●	●	●	●	●	●	●
RS80-1B15T-SS-H□□J	15	122.17	135	93	40	12				●	●	●	●	●	●	●	●	●	●	●	●	●	●	●	●
RS80-1B16T-SS-H□□J	16	130.20	143	93	40	12				●	●	●	●	●	●	●	●	●	●	●	●	●	●	●	●
RS80-1B17T-SS-H□□J	17	138.23	151	93	40	12				●	●	●	●	●	●	●	●	●	●	●	●	●	●	●	●
RS80-1B18T-SS-H□□J	18	146.27	159	93	40	12				●	●	●	●	●	●	●	●	●	●	●	●	●	●	●	●
RS80-1B19T-SS-H□□J	19	154.32	167	93	40	12				●	●	●	●	●	●	●	●	●	●	●	●	●	●	●	●
RS80-1B20T-SS-H□□J	20	162.37	176	93	40	12				●	●	●	●	●	●	●	●	●	●	●	●	●	●	●	●
RS80-1B21T-SS-H□□J	21	170.42	184	93	40	12					●	●	●	●	●	●	●	●	●	●	●	●	●	●	●
RS80-1B22T-SS-H□□J	22	178.48	192	107	45	12					●	●	●	●	●	●	●	●	●	●	●	●	●	●	●
RS80-1B23T-SS-H□□J	23	186.54	200	107	45	12					●	●	●	●	●	●	●	●	●	●	●	●	●	●	●
RS80-1B24T-SS-H□□J	24	194.60	208	107	45	12					●	●	●	●	●	●	●	●	●	●	●	●	●	●	●
RS80-1B25T-SS-H□□J	25	202.66	216	107	45	12					●	●	●	●	●	●	●	●	●	●	●	●	●	●	●

● circles indicate applicable bore diameters.

Before Use
 Standard Roller Chains
 Lube-Free Roller Chains
 Heavy Duty Roller Chains
 Corrosion Resistant Roller Chains
 Specialty Roller Chains
 Sprockets
 Pin Gear Drives
 Accessories
 Selection
 Handling

Torque Limiter Sprockets

Torque limiters are typical mechanical devices for overload protection, and as such it is essential that the friction surface of the center member be finished properly to ensure the precise, accurate overload detection of the torque limiter. Dedicated sprockets for torque limiters are provided with special surface processing to realize the ideal surface finish.

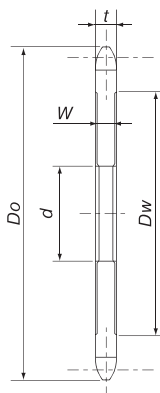

- Manufacturer's recommended value: Former JIS 3S – 6S
- Torque limiter sprocket: Ra 1.6μm and under (roughly former JIS 6S)

Model Numbering Example

RS40-1A 20T-CM 30

Chain no. _____ Finished bore dia. *d*
 Sprocket type (Type A) _____ Torque limiter sprocket
 No. of teeth _____

Chain No.	RS40	RS50	RS60	RS80	RS100
<i>W</i>	6.5	8.0	10.5	13.5	16.5
<i>t</i>	7.3	8.9	11.9	15.0	18.0

- Operating conditions: Sprocket width > Torque limiter bush width (The sprocket width must be larger than the bush width.)
- All other dimensions are the same as those for standard 1A Type sprockets.
- Refer to the following table for the *d* and *D_w* ranges.
- Uses an H7 finished bore diameter (*d*).

Note: Be sure to check the with the torque limiter manufacturer's catalog for the dimensions of each part. Specify the model number of the torque limiter when placing your order.

■ Torque Limiter Compatibility Table (Ref.)

		Applicable sprocket range <i>d</i> × <i>D_w</i>																											
No. of Teeth		16	17	18	19	20	21	22	23	24	25	26	27	28	30	32	34	35	36	38	40	42	45	48	50				
RS40*	TL200	30 × 53																											
	TL250					41 × 68																							
	TL350															49 × 92													
RS50	TL250			41 × 68																									
	TL350														49 × 92														
	TL500																					74 × 134							
RS60	TL350																												
	TL500																												
	TL700																												
RS80	TL500																												
	TL700																												
	TL500																												
RS100	TL500																												
	TL700																												

Sprockets compatible with torque limiters from every major manufacturer are available. We also offer made-to-order sprockets. Contact a Tsubaki representative for more information.

*Check the bush width if TL250 or TL350 are used with RS40 sprockets.

BS Roller Chain Sprockets (conform to BS standards)

Dedicated BS sprockets are required for BS Roller Chains. Please contact a Tsubaki representative for more information.

★ Made-to-order item

(Unit: mm)

RS Chain No.	BS Chain Specifications			BS Sprocket Specifications			
	Pitch	Roller Dia.	Inner Link Inner Width	Tooth Width	Pitch Dia.	Outer Dia.	Corresponding BS/RS Chain Nos.
RF06B	9.53	6.35	5.72	5.30	Same as the basic dimensions of the corresponding RS sprocket model	Roughly the same as the basic dimensions of the corresponding RS sprocket model (may be slightly smaller)	RF06B → RS35
RS08B	12.70	8.51	7.75	7.20			RS08B → RS40
RS10B	15.88	10.16	9.65	9.00			RS10B → RS50
RS12B	19.05	12.07	11.68	11.00			RS12B → RS60
RS16B	25.40	15.88	17.02	16.10			RS16B → RS80
RS20B	31.75	19.05	19.56	18.60			RS20B → RS100
RS24B	38.10	25.40	25.40	24.20			RS24B → RS120
RS28B	44.45	27.94	30.99	29.20			RS28B → RS140
RS32B	50.80	29.21	30.99	29.20			RS32B → RS160
RS40B	63.50	39.37	38.10	36.40			RS40B → RS200

● Model Numbering Example

RS08B-1B 20T

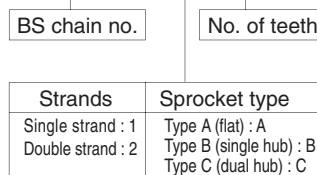

Easy Bore Finishing Service

Easy Bore Finishing Service features

- Coded processing specifications allow for accurate specification confirmation and submittal.
- Processing codes eliminate the need to create or attach drawings when ordering.
- Processing codes also allow for speedy finishing and reliable delivery.

Applicable sprockets and limitations for Easy Bore Finishing Service

Applicable Sprockets	Applicable Models
RS Sprockets (1A, 1B, 2B, and 1C Types)	For all stock items
RS Sprockets (SD Type)	
RS Sprockets (Stainless Steel Series)	

Limitations	We cannot provide delivery drawings, certificates of inspection, or mill sheets. (Orders requiring such items will be treated as standard made-to-order items.)

Processing Range

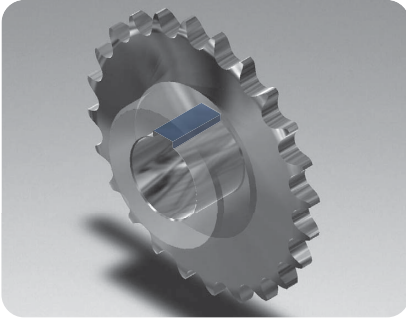
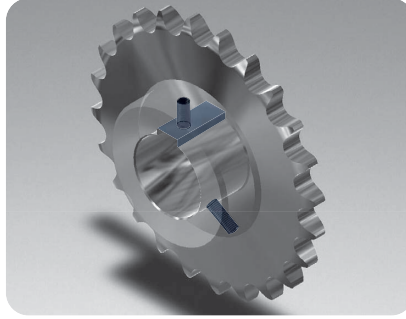
Bore Finishing (L)	Keyway Finishing (K)	Hole Tapping (D)
		
<ul style="list-style-type: none"> · Whole number dimensions only in 1 mm units. No imperial (inch) dimensions available. · Bore tolerances: Choose from H7, G7, or M7. 	<ul style="list-style-type: none"> · Parallel keyways only. · Keyway tolerances: Choose from Js9, F7, P9, or E9. Follows JIS standards for keyway width and height. 	<ul style="list-style-type: none"> · Tapped hole size determined by bore diameter (see pg. 136). · Choose up to two (2) hole locations: <ul style="list-style-type: none"> D1: Above the keyway D2: Above the keyway and at 90° D3: Above the keyway and at 120° (See below) · Set screws provided.

Tapped hole position

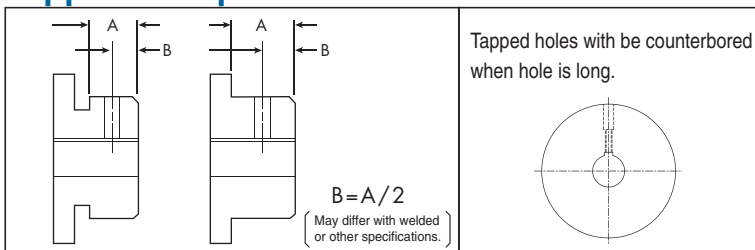

Set screw specifications

- Steel cup point set screws with hexagonal hole
- Use stainless steel screws with stainless steel sprockets



Easy Bore Finishing Service

List of Applicable Sprockets for Easy Bore Finishing Service

RS Sprockets (●: Hardened teeth, ○: Standard teeth, ◎: Both)





Sprocket Model / No. of Teeth	Steel																				Stainless Steel																			
	Single Strand												Double Strand				SD Type				Single Strand Type																			
	35			40			50			60			80			100			120			140			160			40		50		60		80		25	35	40	50	60
	B	A	B	C	A	B	C	A	B	C	A	B	C	A	B	C	A	B	B	B	B	B	B	B	B	40	50	60	80	B	B	B	B	B	B					
9	●		●			●			●																															
10	●		●			●			●					●			●	●	●												○	○	○	○	○	○				
11	●		●			●			●					●			●	●	●												○	○	○	○	○	○				
12	●	◎	●		◎	●		◎	●		◎	●		◎	●		◎	●	●	●	●	●	●	●	●	●	●	●	●	◎	◎	◎	◎	◎	◎					
13	●	◎	●		◎	●		◎	●		◎	●		◎	●		◎	●	●	●	●	●	●	●	●	●	●	◎	◎	◎	◎	◎	◎	◎	◎					
14	●	◎	●		◎	●		◎	●		◎	●		◎	●		◎	●	●	●	●	●	●	●	◎	◎	◎	◎	◎	◎	◎	◎	◎	◎	◎					
15	●	◎	●		◎	●		◎	●		◎	●		◎	●		◎	●	●	●	●	●	◎	◎	◎	◎	◎	◎	◎	◎	◎	◎	◎	◎	◎					
16	●	◎	●		◎	●		◎	●		◎	●		◎	●		◎	●	●	●	●	◎	◎	◎	◎	◎	◎	◎	◎	◎	◎	◎	◎	◎	◎					
17	●	◎	●		◎	●		◎	●		◎	●		◎	●		◎	●	●	●	●	◎	◎	◎	◎	◎	◎	◎	◎	◎	◎	◎	◎	◎	◎					
18	●	◎	●		◎	●		◎	●		◎	●		◎	●		◎	●	●	●	◎	◎	◎	◎	◎	◎	◎	◎	◎	◎	◎	◎	◎	◎	◎					
19	●	◎	●		◎	●		◎	●		◎	●		◎	●		◎	●	●	●	◎	◎	◎	◎	◎	◎	◎	◎	◎	◎	◎	◎	◎	◎	◎					
20	●	◎	●		◎	●		◎	●		◎	●		◎	●		◎	●	●	●	◎	◎	◎	◎	◎	◎	◎	◎	◎	◎	◎	◎	◎	◎	◎					
21	●	◎	●		◎	●		◎	●		◎	●		◎	●		◎	●	●	●	◎	◎	◎	◎	◎	◎	◎	◎	◎	◎	◎	◎	◎	◎	◎					
22	●	◎	●		◎	●		◎	●		◎	●		◎	●		◎	●	●	●	◎	◎	◎	◎	◎	◎	◎	◎	◎	◎	◎	◎	◎	◎	◎					
23	●	◎	●		◎	●		◎	●		◎	●		◎	●		◎	●	●	●	◎	◎	◎	◎	◎	◎	◎	◎	◎	◎	◎	◎	◎	◎	◎					
24	●	◎	●		◎	●		◎	●		◎	●		◎	●		◎	●	●	●	◎	◎	◎	◎	◎	◎	◎	◎	◎	◎	◎	◎	◎	◎	◎					
25	●	◎	●		◎	●		◎	●		◎	●		◎	●		◎	●	●	●	◎	◎	◎	◎	◎	◎	◎	◎	◎	◎	◎	◎	◎	◎	◎					
26	●	◎	●		◎	●		◎	●		◎	●		◎	●		◎	●	●	●	◎	◎	◎	◎	◎	◎	◎	◎	◎	◎	◎	◎	◎	◎	◎					
27	●	◎	●		◎	●		◎	●		◎	●		◎	●		◎	●	●	●	◎	◎	◎	◎	◎	◎	◎	◎	◎	◎	◎	◎	◎	◎	◎					
28	●	◎	●		◎	●		◎	●		◎	●		◎	●		◎	●	●	●	◎	◎	◎	◎	◎	◎	◎	◎	◎	◎	◎	◎	◎	◎	◎					
30	●	◎	●		◎	●		◎	●		◎	●		◎	●		◎	●	◎	◎	◎	◎	◎	◎	◎	◎	◎	◎	◎	◎	◎	◎	◎	◎	◎					
32	●	◎	●		◎	●		◎	●		◎	●		◎	●		◎	●	◎	◎	◎	◎	◎	◎	◎	◎	◎	◎	◎	◎	◎	◎	◎	◎	◎					
34	●	◎	●		◎	●		◎	●		◎	●		◎	●		◎	●	◎	◎	◎	◎	◎	◎	◎	◎	◎	◎	◎	◎	◎	◎	◎	◎	◎					
35	●	◎	●		◎	●		◎	●		◎	●		◎	●		◎	●	◎	◎	◎	◎	◎	◎	◎	◎	◎	◎	◎	◎	◎	◎	◎	◎	◎					
36	●	◎	●		◎	●		◎	●		◎	●		◎	●		◎	●	◎	◎	◎	◎	◎	◎	◎	◎	◎	◎	◎	◎	◎	◎	◎	◎	◎					
38	●	◎	●		◎	●		◎	●		◎	●		◎	●		◎	●	◎	◎	◎	◎	◎	◎	◎	◎	◎	◎	◎	◎	◎	◎	◎	◎	◎					
40	●	◎	●		◎	●		◎	●		◎	●		◎	●		◎	●	◎	◎	◎	◎	◎	◎	◎	◎	◎	◎	◎	◎	◎	◎	◎	◎	◎					
42	○	◎	○		◎	○		◎	○		◎	○		◎	○		◎	○	◎	◎	◎	◎	◎	◎	◎	◎	◎	◎	◎	◎	◎	◎	◎	◎	◎					
45	○	◎	○		◎	○		◎	○		◎	○		◎	○		◎	○	◎	◎	◎	◎	◎	◎	◎	◎	◎	◎	◎	◎	◎	◎	◎	◎	◎					
48	○	◎	○		◎	○		◎	○		◎	○		◎	○		◎	○	◎	◎	◎	◎	◎	◎	◎	◎	◎	◎	◎	◎	◎	◎	◎	◎	◎					
50	○	◎	○		◎	○		◎	○		◎	○		◎	○		◎	○	◎	◎	◎	◎	◎	◎	◎	◎	◎	◎	◎	◎	◎	◎	◎	◎	◎					
54	○	◎	○		◎	○		◎	○		◎	○		◎	○		◎	○	◎	◎	◎	◎	◎	◎	◎	◎	◎	◎	◎	◎	◎	◎	◎	◎	◎					
60	○	◎	○		◎	○		◎	○		◎	○		◎	○		◎	○	◎	◎	◎	◎	◎	◎	◎	◎	◎	◎	◎	◎	◎	◎	◎	◎	◎					
65	○	◎	○		◎	○		◎	○		◎	○		◎	○		◎	○	◎	◎	◎	◎	◎	◎	◎	◎	◎	◎	◎	◎	◎	◎	◎	◎	◎					
70	○	◎	○		◎	○		◎	○		◎	○		◎	○		◎	○	◎	◎	◎	◎	◎	◎	◎	◎	◎	◎	◎	◎	◎	◎	◎	◎	◎					
75	○	◎	○		◎	○		◎	○		◎	○		◎	○		◎	○	◎	◎	◎	◎	◎	◎	◎	◎	◎	◎	◎	◎	◎	◎	◎	◎	◎					

Note: Processing fee for boxes colored blue in the thick outlined area is relatively high.

Before Use
Standard Roller Chains
Lube-Free Roller Chains
Heavy Duty Roller Chains
Corrosion Resistant Roller Chains
Specialty Roller Chains
Sprockets
Pin Gear Drives
Accessories
Selection
Handling

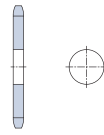
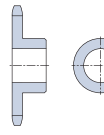
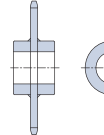
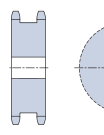
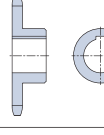
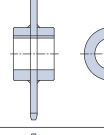
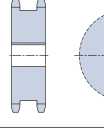
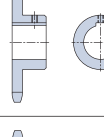
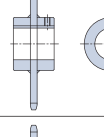
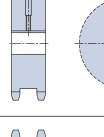
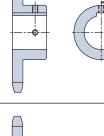
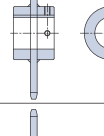
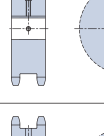
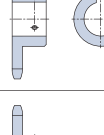
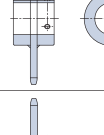
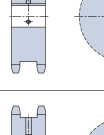
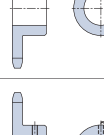
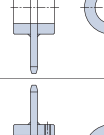
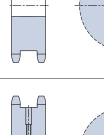
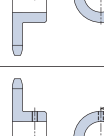
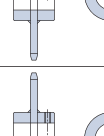
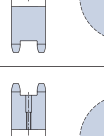
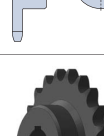
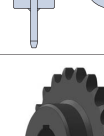
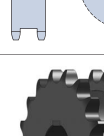
Easy Bore Finishing Service

Processing Code and Details

	Processing Code			A Type	B Type	C Type	SD Type
	Bore	Key	Tap				
I							
II				—			
III			1	—			
			2	—			
			3	—			
IV			1	—			
			2	—			
			3	—			
							

Tap hole "1" shown above is tapped in one spot in the center of the keyway. Tap hole "2" is tapped at a 90° angle to tap hole "1", while tap hole "3" is tapped at a 120° angle to tap hole "1".

List of Finishing Dimensions

With a key tolerance of Js9, P9 (new JIS)

Bore Dia.	Keyway Width	Tap Size	Bore Mounting Dim.
10~12	4	M4	1
13~17	5	M5	
18~20	6	M6	
21~22			1.2
23~30	8	M8	
31~32	10		

With a key tolerance of F7, E9 (former JIS)

Bore Dia.	Keyway Width	Tap Size	Bore Mounting Dim.
10~13	4	M4	1
14~20	5	M5	
21~30	7	M6	1.2
31~32	10	M8	
33~40			1.6
41~50	12		

·With processing code IV (no keyway), the bore mounting dimensions will be half of the new JIS table.

Easy Bore Finishing Service

(Continued from previous page)

With a key tolerance of Js9, P9 (new JIS)

Bore Dia.	Keyway Width	Tap Size	Bore Mounting Dim.
33~38	10	M8	1.6
39~44	12		
45~50	14		
51~58	16	M10	2.5
59~65	18		
66~75	20	M12	3
76~80	22		
81~85	25	M16	3
86~95	28		
96~110	32		
111~130	32	M20	

With a key tolerance of F7, E9 (former JIS)

Bore Dia.	Keyway Width	Tap Size	Bore Mounting Dim.
51~60	15	M8	2.5
61~70	18	M10	
71~80	20	M12	
81~95	24	M16	3
96~110	28		
111~125	32	M20	
126~140	35		

· With processing code IV (no keyway), the bore mounting dimensions will be half of the new JIS table.

Easy Bore Finishing Service Numbering Example

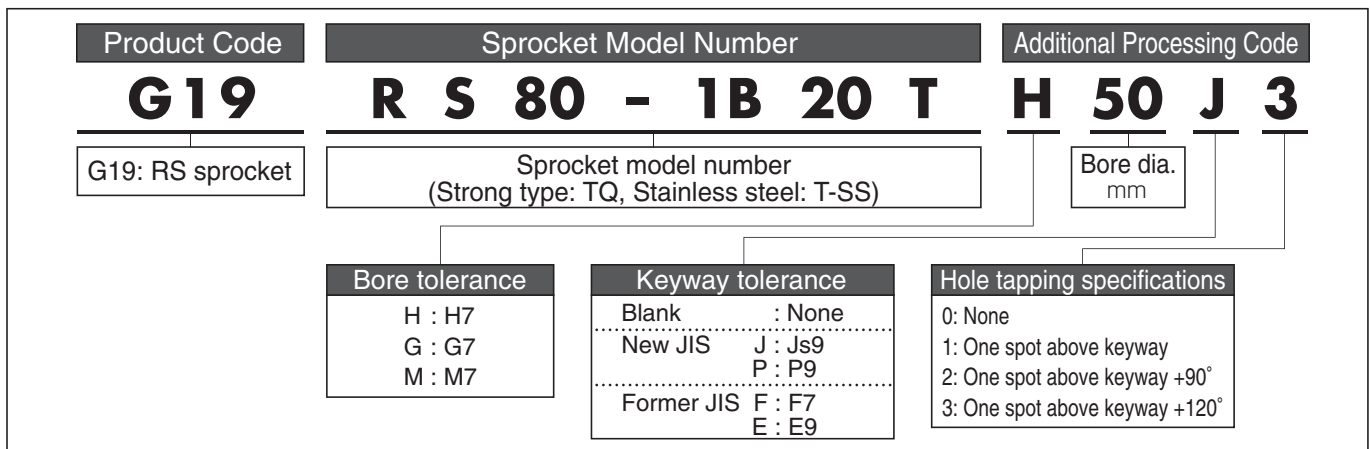

Note: Contact a Tsubaki representative when set screws will differ or the hub length will be machined.

Easy Bore Finishing Service Reference

■ Allowable bore dimensional tolerances

(Taken from JIS B0401-2)

Unit: μm

Bore Classification mm		G7		H6		H7		H8		M7		N7		P7		R7		
More than	Up to	Above	Below	Above	Below	Above	Below	Above	Below	Above	Below	Above	Below	Above	Below	Above	Below	
3	6	+16	+4	+8	0	+12	0	+18	0	+0	-12	-4	-16	-8	-20	-11	-23	
6	10	+20	+5	+9	0	+15	0	+22	0	+0	-15	-4	-19	-9	-24	-13	-28	
10	18	+24	+6	+11	0	+18	0	+27	0	+0	-18	-5	-23	-11	-29	-16	-34	
18	30	+28	+7	+13	0	+21	0	+33	0	+0	-21	-7	-28	-14	-35	-20	-41	
30	40	+34	+9	+16	0	+25	0	+39	0	+0	-25	-8	-33	-17	-42	-25	-50	
40	50																	
50	65	+40	+10	+19	0	+30	0	+46	0	+0	-30	-9	-39	-21	-51	-30	-60	
65	80																	
80	100	+47	+12	+22	0	+35	0	+54	0	+0	-35	-10	-45	-24	-59	-38	-73	
100	120																	
120	140	+54	+14	+25	0	+40	0	+63	0	+0	-40	-12	-52	-28	-68	-48	-88	
140	160																	
160	180	+61	+15	+29	0	+46	0	+72	0	+0	-46	-147	-60	-33	-79	-60	-106	
180	200																	
200	225	+69	+17	+32	0	+52	0	+81	0	+0	-52	-14	-66	-36	-88	-63	-109	
225	250																	
250	280	+75	+18	+36	0	+57	0	+89	0	+0	-57	-16	-73	-41	-98	-67	-113	
280	315																	
315	355	+83	+20	+40	0	+63	0	+97	0	+0	-63	-17	-80	-45	-108	-74	-126	
355	400																	
400	450	+83	+20	+40	0	+63	0	+97	0	+0	-63	-17	-80	-45	-108	-78	-130	
450	500																	
450	500																	

■ Keyway dimensions and tolerances

New JIS (B1301 – 1996)

Former JIS (B1301 – 1959)

Unit: μm

Applicable Bore Dia. d	Keyway Width KW	Tolerance (Js9)	Tolerance (P9)	Keyway Depth KH	Tolerance	Set Screw MX	Applicable Bore Dia. d	Keyway Width KW	Tolerance (F7)	Tolerance (E9)	Keyway Depth KH	Tolerance	Set Screw MX
10~12	4	±0.0150	0.012 -0.042	1.8	+0.1 0	M4	More than 10, up to 13	4	+0.022	+0.050	1.5	+0.050 0	M4
12~17	5			2.3		M5	More than 13, up to 20	5	+0.010	+0.020	2.0		M5
17~22	6			2.8		M6	More than 20, up to 30	7	+0.028	+0.061	3.0		M6
22~30	8	±0.0180	-0.015 -0.051	3.3	+0.2 0	M8	More than 30, up to 40	10	+0.013	+0.025	3.5	+0.050 0	M8
30~38	10			3.3			More than 40, up to 50	12	+0.034	+0.075	5.0		
38~44	12	±0.0215	-0.018 -0.061	3.3	+0.2 0	M10	More than 50, up to 60	15	+0.016	+0.032	6.0	+0.075 0	M10
44~50	14			3.8			More than 60, up to 70	18	+0.041	+0.092	6.0		
50~58	16			4.3			More than 70, up to 80	20	+0.020	+0.040	8.0		
58~65	18	±0.0260	-0.022 -0.074	4.4	+0.2 0	M12	More than 80, up to 95	24	+0.050 +0.025	+0.112 +0.050	9.0	+0.075 0	M12
65~75	20			4.9			More than 95, up to 110	28			9.0		
75~85	22	±0.0310	-0.026 -0.088	5.4	+0.2 0	M16	More than 110, up to 125	32	+0.060 +0.030	+0.134 +0.060	10.0	+0.100 0	M16
85~95	25			5.4			More than 125, up to 140	35			11.0		
95~110	28			6.4			More than 140, up to 160	38			12.0		
110~130	32	±0.0370	-0.032 -0.106	7.4	+0.2 0	M20	More than 160, up to 180	42	+0.071 +0.036	+0.159 +0.072	13.0	+0.100 0	M20
130~150	36			8.4			More than 180, up to 200	45			14.0		
150~170	40	±0.0435	-0.037 -0.124	9.4	+0.2 0	M24	More than 200, up to 224	50	+0.071 +0.036	+0.159 +0.072	15.5	+0.100 0	M24
170~200	45			10.4			More than 224, up to 250	56			17.5		
200~230	50	±0.0370	-0.032 -0.106	11.4	+0.2 0	M24	More than 250, up to 280	63	+0.060 +0.030	+0.134 +0.060	20.0	+0.100 0	M24
230~260	56			12.4			More than 280, up to 315	71			22.5		
260~290	63	±0.0370	-0.032 -0.106	12.4	+0.2 0	M24	More than 315, up to 355	80	+0.071 +0.036	+0.159 +0.072	25.0	+0.100 0	M24
290~330	70			14.4			More than 355, up to 400	90			28.0		
330~380	80	±0.0435	-0.037 -0.124	15.4	+0.2 0	M24	More than 400, up to 450	100	+0.071 +0.036	+0.159 +0.072	31.5	+0.100 0	M24
380~440	90			17.4			More than 450, up to 500	112			35.5		
440~500	100			19.5									

Note: Combinations of Tsubaki standard processing and bore/keyway specifications may differ from the above. Refer to the processing dimension lists on pgs. 136 – 137.

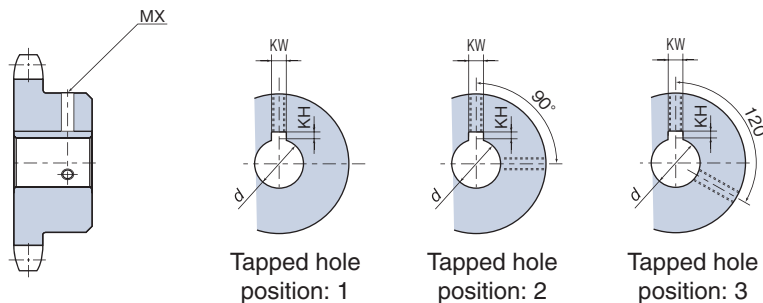

RS Sprocket Engineering Information

1. Part names and standard dimensional formulae

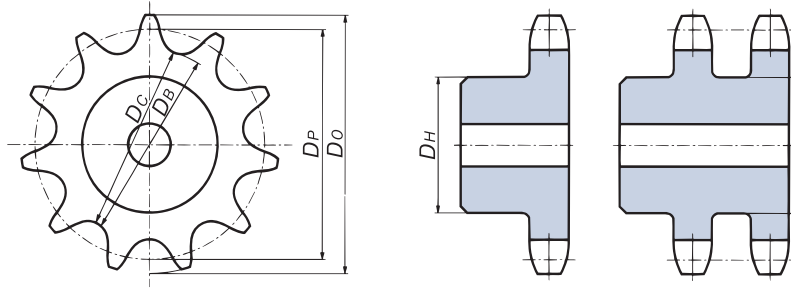

$$D_P = P / \sin \frac{180^\circ}{N}$$

$$D_O = P \left(0.6 + \cot \frac{180^\circ}{N} \right)$$

$$D_B = D_P - d_l$$

$$D_C = D_B \quad (\text{When number of teeth is even})$$

$$D_C = D_P \cos \frac{90^\circ}{N} - d_l \quad (\text{When number of teeth is odd})$$

$$D_H = P \left(\cot \frac{180^\circ}{N} - 1 \right) - 0.76$$

D_P = Pitch diameter

D_O = Standard outer diameter

D_B = Tooth root diameter

D_C = Tooth root distance

D_H = Max. hub diameter and max. groove diameter

P = Chain pitch

d_l = Roller outer diameter

N = Number of teeth

2. Tooth profile specifications

2-1. Tooth profile

Tsubaki sprocket teeth profiles use S profiles from JIS standards, and are machine hobbled. We currently are partially combining these with JIS standard U profiles.

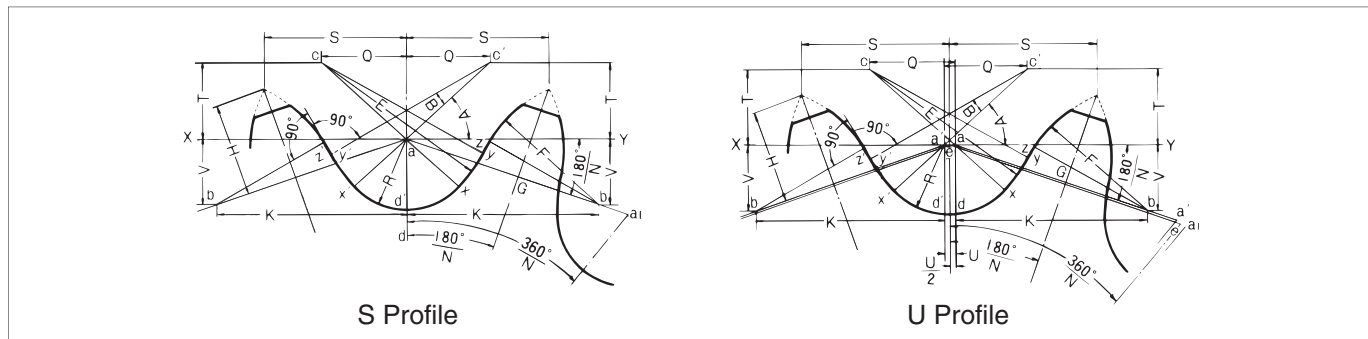

S Profile

U Profile

$$p_a = p \left(1 + \frac{D_s - d_l}{D_P} \right)$$

$$D_S = 2R = 1.005 d_l + 0.076$$

$$U = 0.07 (p - d_l) + 0.051$$

$$R = D_s / 2 = 0.5025 d_l + 0.038$$

$$A = 35^\circ + 60^\circ / N$$

$$B = 18^\circ - 56^\circ / N$$

$$ac = 0.8 d_l$$

$$Q = 0.8 d_l \cos (35^\circ + 60^\circ / N)$$

$$T = 0.8 d_l \sin (35^\circ + 60^\circ / N)$$

$$E = cy = 1.3025 d_l + 0.038$$

$$\bar{xy} = (2.605 d_l + 0.076) \sin (9^\circ - 28^\circ / N)$$

$$yz = d_l [1.4 \sin (17^\circ - 64^\circ / N) - 0.8 \sin (18^\circ - 56^\circ / N)]$$

$$G = ab = 1.4 d_l \quad [\text{Point b forms a line from point a on the XY line to the } 180^\circ / N \text{ angle on the XY line.}]$$

$$K = 1.4 d_l \cos 180^\circ / N$$

$$V = 1.4 d_l \sin 180^\circ / N$$

$$F = d_l [0.8 \cos (18^\circ - 56^\circ / N) + 1.4 \cos (17^\circ - 64^\circ / N) - 1.3025] - 0.038$$

$$H = \sqrt{F^2 - \left(1.4 d_l - \frac{p_a}{2} + \frac{U}{2} \cos 180^\circ / N \right)^2} + \frac{U}{2} \sin 180^\circ / N$$

[Assuming that $U = 0$ for the S profile]

$$S = \frac{p_a}{2} \cos 180^\circ / N + H \sin 180^\circ / N$$

Outer diameter when teeth profiles taper = $p_a \cot 180^\circ / N + 2H$

Max. pressure angle = $x_{ab} = 35^\circ - 120^\circ / N$

Min. pressure angle = $x_{ab} - B = 17^\circ - 64^\circ / N$

Ave. pressure angle = $26^\circ - 92^\circ / N$

N = No. of teeth, d_l = Roller outer dia., D_P = Pitch diameter, p = Chain pitch, p_a = Tooth profile pitch (a-a1 for S profiles, e-e1 for U profiles)

Engineering Information

2-2 Tooth width dimensions

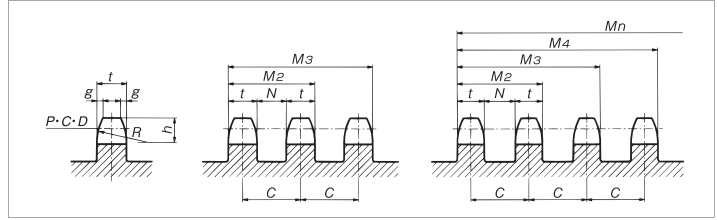

Chain No.	Each Strand			t (Max.)			C	Double/Triple Strands			Quadruple or More Strands					
	g (ref.)	h	R (min.)	Single strand	Double/triple strands	Quadruple or more strands		Double strands or more	M ₂	M ₃	N	M ₂	M ₃	M ₄	M ₅	M ₆
RS 11	0.5	1.9	4.0	1.6	—	—	—	—	—	—	—	—	—	—	—	—
RS 15	0.6	2.4	5.1	2.0	—	—	—	—	—	—	—	—	—	—	—	—
RS 25	0.8	3.2	6.8	2.9	2.8	2.8	6.4	9.2	15.6	3.6	9.2	15.6	22.0	28.4	34.8	3.6
RS 35	1.2	4.8	10.1	4.4	4.3	4.2	10.1	14.4	24.5	5.8	14.3	24.4	34.5	44.6	54.7	5.9
RS 41	1.6	6.4	13.5	5.8	—	—	—	—	—	—	—	—	—	—	—	—
RS 40	1.6	6.4	13.5	7.3	7.1	7.0	14.4	21.5	35.9	7.3	21.4	35.8	50.2	64.6	79.0	7.4
RS 50	2.0	7.9	16.9	8.9	8.7	8.6	18.1	26.8	44.9	9.4	26.7	44.8	62.9	81.0	99.1	9.5
RS 60	2.4	9.5	20.3	11.9	11.7	11.4	22.8	34.5	57.3	11.1	34.2	57.0	79.8	102.6	125.4	11.4
RS 80	3.2	12.7	27.0	15.0	14.6	14.3	29.3	43.9	73.2	14.7	43.6	72.9	102.2	131.5	160.8	15.0
RS100	4.0	15.9	33.8	18.0	17.6	17.2	35.8	53.4	89.2	18.2	53.0	88.8	124.6	160.4	196.2	18.6
RS120	4.7	19.0	40.5	24.0	23.5	23.0	45.4	68.9	114.3	21.9	68.4	113.8	159.2	204.6	250.0	22.4
RS140	5.5	22.2	47.3	24.0	23.5	23.0	48.9	72.4	121.3	25.4	71.9	120.8	169.7	218.6	267.5	25.9
RS160	6.3	25.4	54.0	30.0	29.3	28.7	58.5	87.8	146.3	29.2	87.2	145.7	204.2	262.7	321.2	29.8
RS180	7.1	28.6	60.8	33.7	33.0	32.3	65.8	98.8	164.6	32.8	98.1	163.9	229.7	295.5	361.3	33.5
RS200	8.0	31.8	67.5	36.0	35.2	34.4	71.6	106.8	178.4	36.4	106.0	177.6	249.2	320.8	392.4	37.2
RS240	9.5	38.1	81.0	45.0	44.0	43.1	87.8	131.8	219.6	43.8	130.9	218.7	306.5	394.3	482.1	44.7

Maximum sprocket hub diameter and standard maximum bore diameter

Chain No.	RS25		RS35		RS40 · 41		RS50		RS60		RS80		RS100		RS120		RS140		RS160		RS180		RS200		RS240			
Chain Pitch	6.35		9.525		12.70		15.875		19.05		25.40		31.75		38.10		44.45		50.80		57.15		63.50		76.20			
No. of Teeth	Hub dia.	Max. bore dia.	Hub dia.	Max. bore dia.	Hub dia.	Max. bore dia.	Hub dia.	Max. bore dia.	Hub dia.	Max. bore dia.	Hub dia.	Max. bore dia.	Hub dia.	Max. bore dia.	Hub dia.	Max. bore dia.	Hub dia.	Max. bore dia.	Hub dia.	Max. bore dia.	Hub dia.	Max. bore dia.	Hub dia.	Max. bore dia.	Hub dia.	Max. bore dia.	Hub dia.	Max. bore dia.
10	12	3.2	19	8.8	26	14	32	18	39	22	52	32	65	42	78	50	92	60	105	70	118	78	131	88	158	108		
11	15	5.6	22	11	30	18	37	22	45	27	60	38	76	50	91	60	106	71	121	80	137	92	152	103	183	126		
12	17	7.2	25	13	34	20	43	26	51	31	69	45	86	57	103	69	121	80	138	93	155	106	173	118	207	144		
13	19	8.8	28	15	38	22	48	30	57	36	77	51	96	64	116	79	135	91	155	105	174	119	193	132	232	162		
14	21	10	31	17	42	26	53	33	64	41	85	57	107	72	128	85	150	101	171	117	192	132	214	148	257	180		
15	23	12	35	20	46	28	58	37	70	46	93	61	117	80	140	95	164	111	187	129	211	146	235	163	282	199		
16	25	13	38	21	50	31	63	41	76	51	102	68	127	85	153	104	178	122	204	141	229	159	255	179	306	216		
17	27	14	41	24	54	34	68	45	82	53	110	74	137	93	165	112	193	132	220	152	248	173	275	193	331	232		
18	29	16	44	26	59	37	73	49	88	59	118	80	148	100	177	121	207	144	237	165	266	186	296	208	355	252		
19	31	17	47	29	63	41	79	51	94	62	126	84	158	108	189	129	221	153	253	177	284	199	316	224	380	268		
20	33	19	50	30	67	44	84	55	100	66	134	90	168	114	202	140	235	163	269	188	303	213	337	238	404	283		
21	35	20	53	33	71	47	89	59	107	72	142	95	178	122	214	148	250	175	285	200	321	226	357	254	429	303		
22	37	21	56	35	75	50	94	62	113	77	150	101	188	128	226	157	264	185	302	212	339	239	377	266	453	318		
23	39	22	59	37	79	51	99	65	119	80	159	109	199	137	238	165	278	196	318	224	358	254	398	278	477	338		
24	41	24	62	40	83	54	104	70	125	83	167	113	209	144	251	176	292	205	334	235	376	265	418	294	502	354		
25	43	25	65	42	87	57	109	73	131	88	175	120	219	152	263	184	307	217	351	249	394	275	438	310	526	372		

Note: When selecting max. bore diameter, select a hub wall thickness that matches the operating conditions based on standard machine design. Standard-type max. bore diameters for standard situations (SS400 sprocket, JIS keyway) are shown for your reference. The values have been calculated using JIS hub diameter formulae.

Pin Gear Products Guide

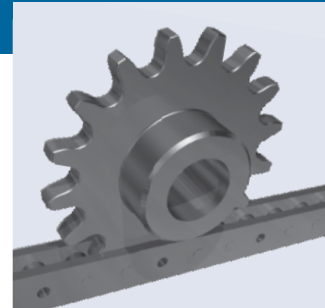
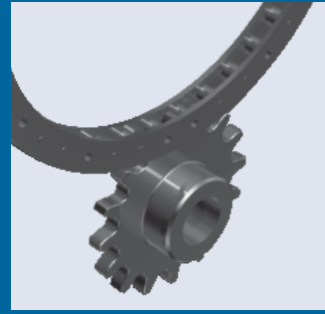

Index

- Sprockets for Chain-type Pin Gears ————— Pg. 142
- Attachment Chains for Chain-type Pin Gears ————— Pg. 143
- Pin Gear Drive Units ————— Pg. 145
- Selection Guide for Pin Gear Drive Units ————— Pg. 150

Chain-type Pin Gears

For linear drive and large radius rotary drives, a chain gear drive is used by a drive source (motor, etc.) through a reducer. Chains require a large space, and gears need precision machining, which can lead to high costs and other issues. Pin gears are perfect in these situations.

An attachment chain is wound around the outside of a drum in place of a gear drive wheel, and a specially machined sprocket is used for the pinion gear. For linear drives, the attachment chain is attached linearly and used in place of a rack.

The following is a rough comparison of pin gears and gear racks.

	Freedom of Layout	Precision	Cost	Durability
Pin Gears	Excellent	OK	Good	Good
Gear Racks	Poor	Good	OK	OK

● Pin Gear Drive Types

There are linear, inner rotary, and outer rotary pin gear drives.

Linear

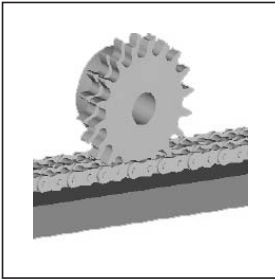

Inner rotary



Outer rotary



Sprockets for Chain-type Pin Gears

Unlike sprockets where the chain wraps around them, sprockets for pin gears engage the chain, which requires them to have special teeth profiles. Using a unique principle, Tsubaki's special tooth profiles are designed for the lowest possible backlash and enable smooth engagement. Especially, the tooth profile changes to match the mounting diameter of the pin gear chain in inner/outer rotary applications for the optimal pin gear drive.

Contact a Tsubaki representative for more information.

● Reference Dimensions

Reference values for pin gear sprockets by number of teeth.

(Unit : mm)

Tooth Width	RS40		RS50		RS60		RS80		RS100		RS120		RS140		RS160	
	Pitch Diameter D_P	Outer Diameter D_o	Pitch Diameter D_P	Outer Diameter D_o	Pitch Diameter D_P	Outer Diameter D_o	Pitch Diameter D_P	Outer Diameter D_o	Pitch Diameter D_P	Outer Diameter D_o	Pitch Diameter D_P	Outer Diameter D_o	Pitch Diameter D_P	Outer Diameter D_o	Pitch Diameter D_P	Outer Diameter D_o
15	62.29	70.9	77.77	88.1	93.32	106.3	124.17	141.8	155.09	177.9	186.11	212.8	216.94	247.7	247.94	282.2
16	66.33	75.1	82.82	93.3	99.38	112.6	132.26	150.1	165.19	188.1	198.23	224.9	231.09	261.6	264.11	298.4
17	70.37	79.3	87.87	98.6	105.45	119.0	140.34	158.6	175.30	198.2	210.36	237.0	245.24	275.7	280.28	314.6
18	74.42	83.5	92.93	103.9	111.51	125.3	148.43	167.1	185.41	208.3	222.49	249.2	259.39	289.9	296.45	330.7
19	78.46	87.8	97.98	109.1	117.57	131.5	156.51	175.4	195.51	218.4	234.62	261.3	273.54	304.0	312.62	346.9
20	82.50	92.0	103.03	114.3	123.64	137.9	164.60	183.7	205.62	228.5	246.74	273.4	287.69	318.2	328.79	363.1
21	86.54	96.0	108.09	119.6	129.70	144.0	172.68	191.7	215.73	238.6	258.87	285.5	301.84	332.3	344.96	379.3
22	90.56	100.1	113.14	124.9	135.77	150.1	180.77	199.8	225.83	248.7	271.00	297.7	315.99	346.5	361.13	395.4
23	94.63	104.1	118.19	130.2	141.83	156.1	188.85	207.9	235.94	258.8	283.13	309.8	330.14	360.6	377.30	411.6
24	98.67	108.2	123.24	135.4	147.89	162.2	196.94	216.0	246.04	268.9	295.25	321.9	344.28	374.8	393.47	427.8
25	102.71	112.2	128.30	140.5	153.96	168.2	205.02	224.1	256.15	279.0	307.38	334.1	358.43	388.9	409.64	443.9

■ Model Numbering Example

See pg. 182 for selection.

RS80-1B 18T G

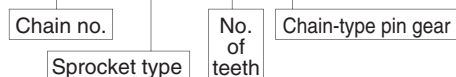

Attachment Chains for Chain-type Pin Gears

K1 Attachment

SK1 Attachment

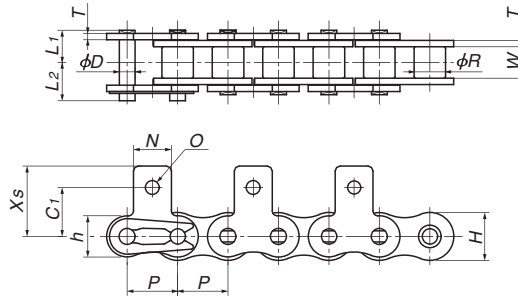
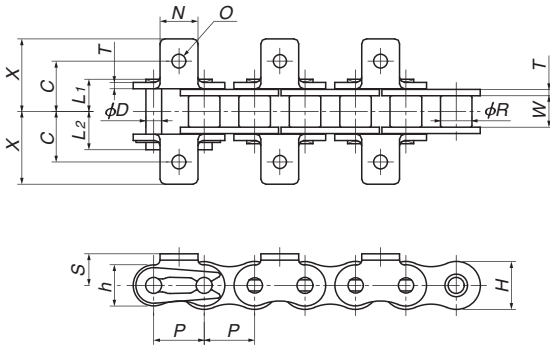

Connecting Links

RS40 – RS60: Clip type
RS80 – RS200: Cotter pin type
RS240: Spring pin type

Attachment dimensions are all common to standard K1 and SK1 attachment chains. (See the Tsubaki Small Size Conveyor Chain catalog for more information.)

TSUBAKI Chain Number	Pitch P	Roller Diameter R	Inner Link Inner Width W	Plate			Pin			Average Tensile Strength kN{kgf}	Maximum Allowable Load kN{kgf}	Approximate Mass kg/m
				Thickness T	Width H	Width h	Dia. D	L1	L2			
RS40	12.70	7.92	7.95	1.5	12.0	10.4	3.97	8.25	9.95	16.7{1700}	2.16{220}	0.64
RS50	15.875	10.16	9.53	2.0	15.0	13.0	5.09	10.3	12.0	27.5{2800}	4.12{420}	1.04
RS60	19.05	11.91	12.70	2.4	18.1	15.6	5.96	12.85	14.75	40.2{4100}	4.90{500}	1.53
RS80	25.40	15.88	15.88	3.2	24.1	20.8	7.94	16.25	19.25	68.6{7000}	9.41{960}	2.66
RS100	31.75	19.05	19.05	4.0	30.1	26.0	9.54	19.75	22.85	108{11000}	15.7{1600}	3.99
RS120	38.10	22.23	25.40	4.8	36.2	31.2	11.11	24.9	28.90	151{15400}	20.6{2100}	5.93
RS140	44.45	25.40	25.40	5.6	42.2	36.4	12.71	26.9	31.70	204{20800}	29.4{3000}	7.49
RS160	50.80	28.58	31.75	6.4	48.2	41.6	14.29	31.85	36.85	258{26300}	37.3{3800}	10.10
RS200	63.50	39.68	38.10	8.0	60.3	52.0	19.85	39.0	44.80	431{44000}	46.1{4700}	16.49
RS240	76.20	47.63	47.63	9.5	72.4	62.4	23.81	47.9	55.50	667{68000}	68.6{7000}	24.50

TSUBAKI Chain Number	Attachment							K1/SK1 Additional Weight per Attachment Location kg	Number of Links per Unit	Delivery
	C	C1	N	O	S	X	Xs			
RS40	12.7	12.7	9.5	3.6	8.0	17.8	17.40	0.004	240	Contact a Tsubaki representative.
RS50	15.9	15.9	12.7	5.2	10.3	23.4	23.05	0.006	192	
RS60	19.05	18.3	15.9	5.2	11.9	28.2	26.85	0.014	160	
RS80	25.4	24.6	19.1	6.8	15.9	36.6	35.45	0.026	120	
RS100	31.75	31.8	25.4	8.7	19.8	44.9	44.00	0.052	96	
RS120	38.1	36.5	28.6	10.3	23.0	55.8	52.85	0.088	80	
RS140	44.5	44.5	34.9	11.9	28.6	63.1	63.50	0.142	68	
RS160	50.8	50.8	38.1	14.3	31.8	71.8	70.10	0.194	60	
RS200	63.5	63.5	48.0	17.5	42.9	83.5	85.50	0.356	48	
RS240	76.2	76.2	57.2	21.0	47.7	97.9	106.70	0.553	40	

Note: Use heat treated mounting bolts. (See pg. 182 for selection.)

Model Numbering Example

See pg. 182 for selection.

RS80-1L K1



Attachment Chains for Chain-type Pin Gears

WK2 Attachment

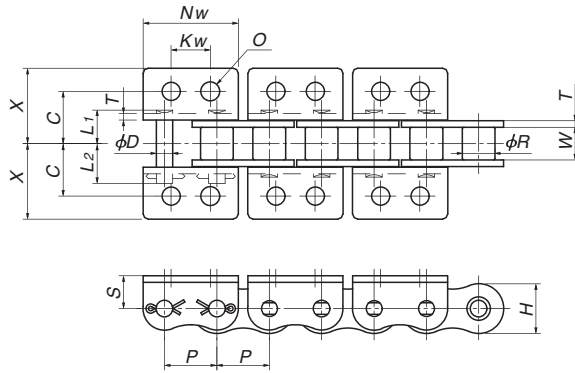

1. Attachment hole diameter is larger than that of K1 attachment chain, and bolt strength is greater.
2. Attachment strength is greater than that of K1 attachment chain.
3. RS200 and RS240 chains use flat plates.
4. Spring pins are used with RS240 connecting links.
5. Made-to-order item.

Attachment dimensions are all common to standard WK2 attachment chains. (See the Tsubaki Small Size Conveyor Chain catalog for more information.)

Product Code	TSUBAKI Chain Number	Pitch P	Roller Diameter R	Inner Link Inner Width W	Plate		Pin			Average Tensile Strength kN{kgf}	Maximum Allowable Load kN{kgf}	Approximate Mass kg/m
					Thickness T	Width H	Dia. D	L1	L2			
B11	RS40	12.70	7.92	7.95	1.5	12.0	3.97	8.25	9.95	16.7{1700}	2.65{270}	0.64
	RS50	15.875	10.16	9.53	2.0	15.0	5.09	10.3	12.0	27.5{2800}	4.31{440}	1.04
	RS60	19.05	11.91	12.70	2.4	18.1	5.96	12.85	14.75	40.2{4100}	6.28{640}	1.53
	RS80	25.40	15.88	15.88	3.2	24.1	7.94	16.25	19.25	68.6{7000}	10.7{1090}	2.66
	RS100	31.75	19.05	19.05	4.0	30.1	9.54	19.75	22.85	108{11000}	17.1{1740}	3.99
	RS200	63.50	39.68	38.10	8.0	60.3	19.85	39.0	44.8	431{44000}	46.1{4700}	16.49
	RS240	76.20	47.63	47.63	9.5	72.4	23.81	47.9	55.5	667{68000}	68.6{7000}	24.15

TSUBAKI Chain Number	Attachment						WK2 Additional Weight per Attachment Location kg	Number of Links per Unit	Delivery
	C	X	Nw	Kw	O	S			
RS40	12.7	17.8	23.0	9.5	4.5	8.0	0.006	240	Contact a Tsubaki representative.
RS50	15.9	23.4	28.8	11.9	5.5	10.3	0.014	192	
RS60	19.05	28.2	34.6	14.3	6.6	11.9	0.024	160	
RS80	25.4	36.6	46.1	19.1	9.0	15.9	0.056	120	
RS100	31.75	44.9	57.7	23.8	11.0	19.8	0.110	96	
RS200	63.5	83.5	115.4	63.5	17.5	42.9	0.857	48	
RS240	76.2	97.9	138.5	57.0	21.0	47.7	1.338	40	

RF320-T-K1 Attachment Chain

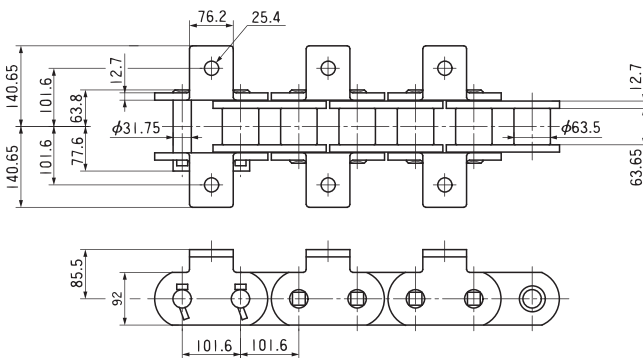

RS400-T-K1 Attachment Chain

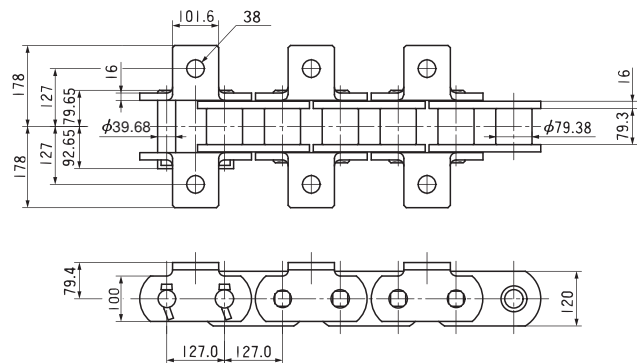

Product Code	TSUBAKI Chain Number	Average Tensile Strength kN{kgf}	Maximum Allowable Load kN{kgf}	Approximate Mass kg/m	K1 Additional Weight per Attachment Location kg	Number of Links per Unit	Delivery
B11	RF320-T	1150{117000}	104{10600}	47.6	1.732	30	Contact a Tsubaki representative.
	RF400-T	1950{199000}	176{17900}	83.9	3.136	24	

★See pg. 182 for selection

Pin Gear Drive Units

A new drive system to replace gears and racks.

Construction A pin gear drive unit is a drive unit with a pin gear and engaging pin rack (or pin wheel) set.

Linear Drives

Pin Rack

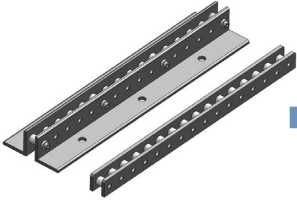

Pin Gear



Pin rack length (number of pins) can be designed freely.

Rotary Drives

Pin Wheels



Pin Gears



Pin wheel diameter (number of pins) can be designed freely.

Features

• Simple installation, rough mounting OK

Both the pin racks and pin wheels use hollow pins for installation, making it easy to use the hole for mounting.

• Segmented units allow for assembly on large equipment

With racks, the joining faces can be aligned to ensure unit pitch spacing is maintained and to enable long linear drive.

Pin wheels for large equipment are also segmented for assembly, enabling large diameter pin wheels.

• Larger transmission power than chain types, enabling small sized operations.

Pin Wheel

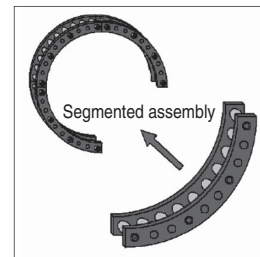

Construction

Pin gears feature special tooth profiles for smooth, continuous engagement with the rollers. Teeth have been hardened to increase their strength and wear resistance.

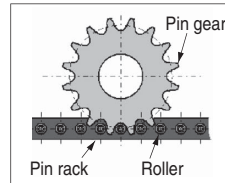

Unique Pin Gear Tooth Profile

The pin gear tooth profile is an approximation of an involute curve to provide smooth engagement and power transmission between pin wheel and rack. They also incorporate a unique Tsubaki design to give them even further strength.

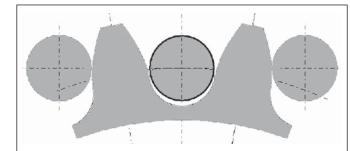

Unique Pin Gear Unit
Tooth Profile

Usage Examples

Linear Cart Drive

(Sample model no.) PDU35-AR-500P/24T
(Application) Drive for transverse cart conveying automotive parts

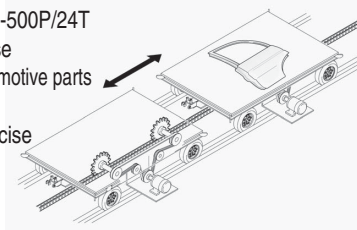

Installation precision is less precise than with gear racks, making assembly a snap.

Table Drive

(Sample model no.) PDU40-NW-240P/20T
(Application) Drive for part assembly table

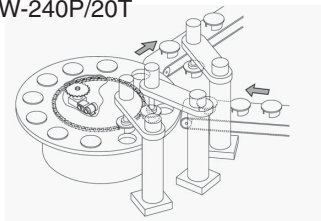

Much cheaper than an intra-cylindrical gear.

Drum Drive

(Sample model no.) PDU55-GW-90P/21T
(Application) Drive for drum rotation

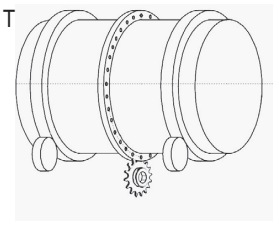

Switched from gears – easier to mount than cylindrical gears.

Swivel Drive

(Sample model no.) PDU35-GW-75P/150P (semicircular)/19T
(Application) Drive for branching equipment on a powder conveyor

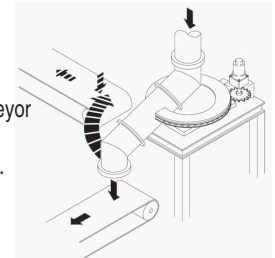

Easier to assembly than a chain-type unit.

Pin Gear Drive Units

Specifications Tsubaki features both Standard Series (steel) and S Series (stainless steel) pin gear drive units to match your usage environment.

New for 2012

- The hollow pin (bush) used for attaching the unit to the frame is now every pitch, instead of every third pitch.
- The construction of the S Series (stainless steel) is not the same as the Standard Series.

List of Specifications

Pitch* ¹ mm	Standard Series (steel)			S Series (stainless steel)		
	Frame model	Allowable Tangential Load F _p (kN)	Backlash (Ref.)* ²	Frame model	Allowable Tangential Load F _p (kN)	Backlash (Ref.)* ²
20	PDU20	4.7	0.26 ~ 0.47	PDUS20	0.8	0.26 ~ 0.47
22	PDU22	7.7	0.32 ~ 0.57	PDUS22	1.1	0.32 ~ 0.57
30	PDU30	12.8	0.32 ~ 0.66	PDUS30	1.9	0.32 ~ 0.67
35	PDU35	19.5	0.33 ~ 0.88	PDUS35	2.6	0.33 ~ 0.88
40	PDU40	27.3	0.41 ~ 0.86	PDUS40	4.1	0.41 ~ 0.86
50	PDU50	31.7	0.53 ~ 0.98	PDUS50	5.1	0.53 ~ 1.08
55	PDU55	52.9	0.61 ~ 1.06	PDUS55	7.0	0.61 ~ 1.26
70	PDU70	60.7	0.86 ~ 1.24	PDUS70	9.9	0.86 ~ 1.61
80	PDU80	71.5	0.89 ~ 1.20	PDUS80	12.0	0.89 ~ 1.74
90	PDU90	98.9	0.97 ~ 1.42	PDUS90	16.8	0.97 ~ 1.92
120	PDU120	122.5	1.30 ~ 1.57	—	—	—
Allowable Speed	Tangential speed: 50m/min					
Operating Environment	Indoors (no contact with water)			Corrosive environments		
Operating Temperature	-10°C to 150°C			-20°C to 400°C		
Material	Frame	Rolled steel		Frame	Austenitic stainless steel	
	Bush/roller	Alloy steel		Bush/roller	Precipitation hardened stainless steel, others	
	Pin gear	Carbon steel		Pin gear	Austenitic stainless steel, others	

*1: The pin wheel pitch is a circular pitch.

*2: The amount of backlash (mm) above is a calculated value and not a guaranteed value. The amount of backlash may fluctuate with wear on the pin gear drive unit and pin gear.

Special Specifications Contact a Tsubaki representative regarding made-to-order items.

Surface Treatment	<ul style="list-style-type: none"> • Black coating ————— Attractive appearance, some rust prevention • Electroless Ni-P plating ————— Corrosion and wear resistance • NEP coating ————— High corrosion resistance
Locking Pin Gear	<ul style="list-style-type: none"> • Pin gear with a frictional locking mechanism ————— Easy positioning (*not available for S Series)
Small Backlash	Has 2/3 to 1/2 the standard backlash.

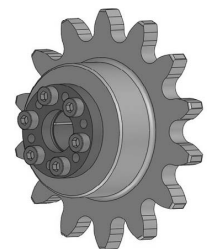

Locking Pin Gear

Lubrication

Coat all roller outer surfaces with an extreme pressure grease before operation. The pin wheel and inner surfaces of the pin rack rollers have already been greased. Contact a Tsubaki representative if you are using the unit in an environment where you cannot grease, such as underwater, or in 130°C temperatures or above.

Installation

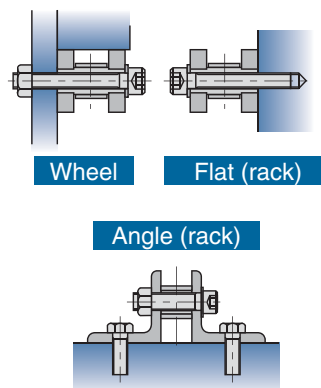

Uses a hollow pin. Use the pin hole to bolt the outer surface to the adjoining equipment. A stopper or guide can be installed on the surface of the protruding area to allow for positioning when installing.

Angled linear racks have a hole for fastening bolts. Use them to bolt the feet to the adjoining equipment.

Pin Gear Drive Units

Pin Wheel Models and Specifications

Outer Drive Pin Wheel

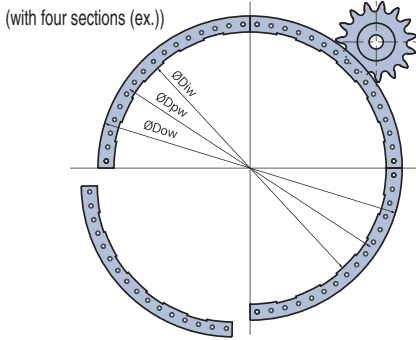

Inner Drive Pin Wheel

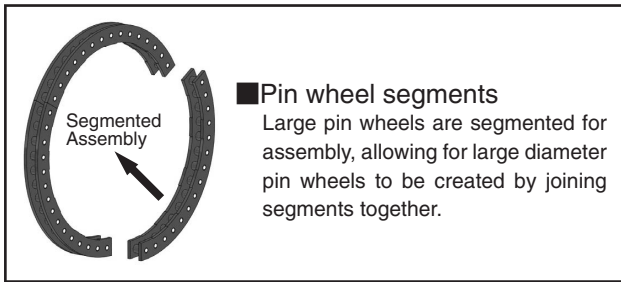
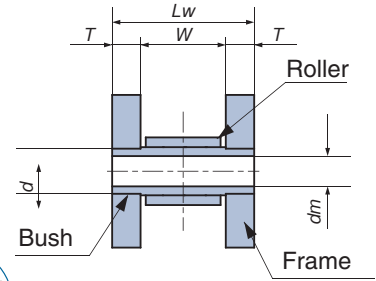
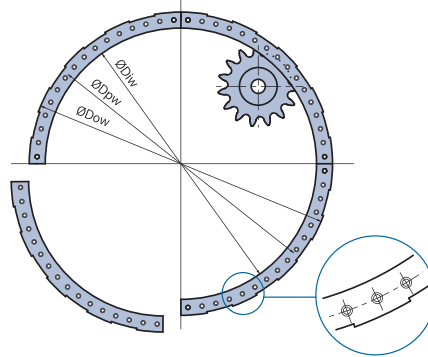

Pin wheel segments
Large pin wheels are segmented for assembly, allowing for large diameter pin wheels to be created by joining segments together.

- * 1. There are protrusions on the inner side of each outer drive wheel segment, or on the outer side of each inner drive wheel segment. These form the reference surface for mounting on the partner equipment.
- 2. The inner diameter Diw of the outer drive pin wheel and the outer diameter Dow of the inner drive pin wheel are the outer and inner dimensions of the partner equipment.
- 3. No mounting bolts are provided.
- 4. Pin wheels with numbers of rollers besides those listed available.
- 5. Pin wheels with partial circumferences (less than 360°) available.

Model Numbering Example

PDU70 – GW – 70P

Frame no. PDU : Standard Series
PDU : S Series No. of rollers Pin wheel type GW : Outer drive
NW : Inner drive

Pin Wheel Specifications Table (Be aware that no mounting bolts are provided.)

Frame model	PDU20 (Standard Series) PDU20 (S Series)				PDU22 (Standard Series) PDU22 (S Series)				PDU30 (Standard Series) PDU30 (S Series)			
	Number of Rollers NT	Number of Segments	Pitch Diameter Dpw	Outer Drive Dow	Inner Drive Diw	Number of Segments	Pitch Diameter Dpw	Outer Drive Dow	Inner Drive Diw	Number of Segments	Pitch Diameter Dpw	Outer Drive Dow
Specifications	Circular pitch P	20		Circular pitch P	22		Circular pitch P	30				
	Roller diameter ϕd	10.16		Roller diameter ϕd	11.91		Roller diameter ϕd	15.88				
	Total width Lw	Standard : 21 S : 22		Total width Lw	Standard : 25 S : 26		Total width Lw	Standard : 31 S : 31				
	Inner width W	12		Inner width W	16		Inner width W	19				
	Frame thickness T	Standard : 4.5 S : 5		Frame thickness T	Standard : 4.5 S : 5		Frame thickness T	Standard : 6 S : 6				
	Mounting hole ϕdm	4.5		Mounting hole ϕdm	4.5		Mounting hole ϕdm	6.4				
	Mounting bolt size	M4		Mounting bolt size	M4		Mounting bolt size	M6				
60	1	381.97	404	359	1	420.17	445	396	1	572.96	605	540
70	1	445.63	468	423	1	490.20	515	466	1	668.45	701	636
80	1	509.30	532	487	1	560.23	585	536	1	763.94	796	731
90	1	572.96	595	550	1	630.25	655	606	3	859.44	892	827
100	1	636.62	659	614	1	700.28	725	676	4	954.93	987	922
110	1	700.28	723	678	1	770.31	795	746	4	1050.42	1083	1018
120	1	763.94	786	741	3	840.34	865	816	5	1145.92	1178	1113
130	3	827.61	850	805	4	910.37	935	886	5	1241.41	1274	1209
140	3	891.27	914	869	4	980.39	1005	956	6	1336.90	1369	1304
150	4	954.93	977	932	4	1050.42	1075	1026	6	1432.39	1465	1400
160	4	1018.59	1041	996	5	1120.45	1145	1096	6	1527.89	1560	1495
170	4	1082.25	1105	1060	5	1190.48	1215	1166	7	1623.38	1656	1591
180	5	1145.92	1168	1123	5	1260.51	1285	1236	7	1718.87	1751	1686
190	5	1209.58	1232	1187	5	1330.54	1355	1306	8	1814.37	1847	1782
200	5	1273.24	1296	1251	6	1400.56	1425	1376	8	1909.86	1942	1877
220	6	1400.56	1423	1378	6	1540.62	1565	1516	9	2100.85	2133	2068
240	6	1527.89	1550	1505	7	1680.68	1705	1656	9	2291.83	2324	2259
260	7	1655.21	1678	1633	8	1820.73	1845	1796	10	2482.82	2515	2450
280	7	1782.54	1805	1760	8	1960.79	1985	1936	11	2673.80	2706	2641
300	8	1909.86	1932	1887	9	2100.85	2125	2076	12	2864.79	2897	2832

Pin wheels with numbers of rollers besides those listed are available.

Pin Gear Drive Units

Frame model	PDU35 (Standard Series) PDU35 (S Series)				PDU40 (Standard Series) PDU40 (S Series)				PDU50 (Standard Series) PDU50 (S Series)				PDU55 (Standard Series) PDU55 (S Series)			
Specifications	Circular pitch P	35			Circular pitch P	40			Circular pitch P	50			Circular pitch P	55		
	Roller diameter ϕd	19.05			Roller diameter ϕd	22.23			Roller diameter ϕd	25.4			Roller diameter ϕd	28.58		
	Total width Lw	Standard : 40 S : 34			Total width Lw	Standard : 46 S : 44			Total width Lw	Standard : 52 S : 46			Total width Lw	Standard : 60 S : 54		
	Inner width W	22			Inner width W	28			Inner width W	28			Inner width W	36		
	Frame thickness T	Standard : 9 S : 6			Frame thickness T	Standard : 9 S : 8			Frame thickness T	Standard : 12 S : 9			Frame thickness T	Standard : 12 S : 9		
	Mounting hole ϕdm	9			Mounting hole ϕdm	10.8			Mounting hole ϕdm	12.8			Mounting hole ϕdm	12.8		
	Mounting bolt size	M8			Mounting bolt size	M10			Mounting bolt size	M12			Mounting bolt size	M12		
Number of Rollers NT	Number of Segments	Pitch Diameter Dpw	Outer Drive Dow	Inner Drive Diw	Number of Segments	Pitch Diameter Dpw	Outer Drive Dow	Inner Drive Diw	Number of Segments	Pitch Diameter Dpw	Outer Drive Dow	Inner Drive Diw	Number of Segments	Pitch Diameter Dpw	Outer Drive Dow	Inner Drive Diw
60	1	668.45	709	628	3	763.94	812	715	3	954.93	1010	899	3	1050.42	1115	986
70	3	779.86	820	739	4	891.27	940	843	4	1114.08	1170	1059	4	1225.49	1290	1161
80	4	891.27	932	851	4	1018.59	1067	970	4	1273.24	1329	1218	5	1400.56	1465	1336
90	4	1002.68	1043	962	5	1145.92	1194	1097	5	1432.39	1488	1377	5	1575.63	1640	1511
100	5	1114.08	1155	1074	5	1273.24	1322	1225	5	1591.55	1647	1536	6	1750.70	1815	1686
110	5	1225.49	1266	1185	6	1400.56	1449	1352	6	1750.70	1806	1695	6	1925.77	1990	1861
120	6	1336.90	1377	1296	6	1527.89	1576	1479	6	1909.86	1965	1854	7	2100.85	2165	2036
130	6	1448.31	1489	1408	7	1655.21	1704	1607	7	2069.01	2125	2014	8	2275.92	2340	2211
140	6	1559.72	1600	1519	7	1782.54	1831	1734	7	2228.17	2284	2173	8	2450.99	2515	2386
150	7	1671.13	1712	1631	8	1909.86	1958	1861	8	2387.32	2443	2332	9	2626.06	2691	2562
160	7	1782.54	1823	1742	8	2037.18	2086	1989	8	2546.48	2602	2491	9	2801.13	2866	2737
170	8	1893.94	1934	1853	9	2164.51	2213	2116	9	2705.63	2761	2650	10	2976.20	3041	2912
180	8	2005.35	2046	1965	10	2291.83	2340	2243	9	2864.79	2920	2809	10	3151.27	3216	3087
190	9	2116.76	2157	2076	10	2419.16	2468	2371	10	3023.94	3079	2968	11	3326.34	3391	3262
200	9	2228.17	2269	2188	11	2546.48	2595	2498	11	3183.10	3239	3128	12	3501.41	3566	3437
220	10	2450.99	2491	2410	12	2801.13	2850	2753	12	3501.41	3557	3446	13	3851.55	3916	3787
240	11	2673.80	2714	2633	13	3055.77	3104	3007	13	3819.72	3875	3764	14	4201.69	4266	4137
260	12	2896.62	2937	2856	14	3310.42	3359	3262	14	4138.03	4194	4083	15	4551.83	4616	4487
280	13	3119.44	3160	3079	15	3565.07	3614	3517	15	4456.34	4512	4401	16	4901.97	4966	4837
300	14	3342.25	3383	3302	16	3819.72	3868	3771	16	4774.65	4830	4719	17	5252.11	5317	5188

Frame model	PDU70 (Standard Series) PDU70 (S Series)				PDU80 (Standard Series) PDU80 (S Series)				PDU90 (Standard Series) PDU90 (S Series)				PDU120 (Standard Series)			
Specifications	Circular pitch P	70			Circular pitch P	80			Circular pitch P	90			Circular pitch P	120		
	Roller diameter ϕd	35.71			Roller diameter ϕd	39.68			Roller diameter ϕd	47.63			Roller diameter ϕd	63.5		
	Total width Lw	Standard : 72 S : 60			Total width Lw	Standard : 74 S : 66			Total width Lw	Standard : 90 S : 76			Total width Lw	Standard : 112		
	Inner width W	40			Inner width W	42			Inner width W	52			Inner width W	68		
	Frame thickness T	Standard : 16 S : 10			Frame thickness T	Standard : 16 S : 12			Frame thickness T	Standard : 19 S : 12			Frame thickness T	Standard : 22		
	Mounting hole ϕdm	17			Mounting hole ϕdm	17			Mounting hole ϕdm	22			Mounting hole ϕdm	32		
	Mounting bolt size	M16			Mounting bolt size	M16			Mounting bolt size	M20			Mounting bolt size	M30		
Number of Rollers NT	Number of Segments	Pitch Diameter Dpw	Outer Drive Dow	Inner Drive Diw	Number of Segments	Pitch Diameter Dpw	Outer Drive Dow	Inner Drive Diw	Number of Segments	Pitch Diameter Dpw	Outer Drive Dow	Inner Drive Diw	Number of Segments	Pitch Diameter Dpw	Outer Drive Dow	Inner Drive Diw
60	4	1336.90	1409	1264	5	1527.89	1608	1447	6	1718.87	1815	1622	8	2291.83	2442	2141
70	5	1559.72	1632	1487	6	1782.54	1863	1702	7	2005.35	2102	1909	9	2673.80	2824	2523
80	6	1782.54	1855	1710	7	2037.18	2118	1957	8	2291.83	2388	2195	10	3055.77	3206	2905
90	7	2005.35	2078	1933	8	2291.83	2372	2211	9	2578.31	2675	2482	12	3437.75	3588	3287
100	7	2228.17	2301	2156	9	2546.48	2627	2466	10	2864.79	2961	2768	13	3819.72	3970	3669
110	8	2450.99	2523	2378	9	2801.13	2882	2721	11	3151.27	3248	3055	14	4201.69	4352	4051
120	9	2673.80	2746	2601	10	3055.77	3136	2975	12	3437.75	3534	3341	15	4583.66	4734	4433
130	10	2896.62	2969	2824	11	3310.42	3391	3230	12	3724.23	3821	3628	16	4965.63	5116	4815
140	10	3119.44	3192	3047	12	3565.07	3646	3485	13	4010.70	4107	3914	18	5347.61	5498	5197
150	11	3342.25	3415	3270	13	3819.72	3900	3739	14	4297.18	4394	4201	19	5729.58	5880	5579
160	12	3565.07	3638	3493	13	4074.37	4155	3994	15	4583.66	4680	4487	20	6111.55	6262	5961
170	12	3787.89	3860	3715	14	4329.01	4410	4249	16	4870.14	4967	4774	21	6493.52	6644	6343
180	13	4010.70	4083	3938	15	4583.66	4664	4503	17	5156.62	5253	5060	22	6875.49	7026	6725
190	14	4233.52	4306	4161	16	4838.31	4919	4758	18	5443.10	5540	5347	24	7257.47	7408	7107
200	15	4456.34	4529	4384	17	5092.96	5173	5012	19	5729.58	5826	5633	25	7639.44	7790	7489
220	16	4901.97	4974	4829	18	5602.25	5683	5522	21	6302.54	6399	6206	27	8403.38	8554	8253
240	17	5347.61	5420	5275	20	6111.55	6192	6031	22	6875.49	6972	6779	30	9167.32	9318	9017
260	19	5793.24	5866	5721	21	6620.85	6701	6540	24	7448.45	7545	7352	32	9931.27	10082	9781
280	20	6238.87	6311	6166	23	7130.14	7211	7050	26	8021.41	8118	7925	35	10695.21	10846	10545
300	22	6684.51	6757	6612	25	7639.44	7720	7559	28	8594.37	8691	8498	37	11459.16	11610	11309

Pin wheels with numbers of rollers besides those listed are available.

Before Use
Standard Roller Chains
Lube-Free Roller Chains
Heavy Duty Roller Chains
Corrosion Resistant Roller Chains
Specialty Roller Chains
Sprockets
Pin Gear Drives
Accessories
Selection
Handling

Pin Gear Drive Units

Pin Rack Models and Specifications

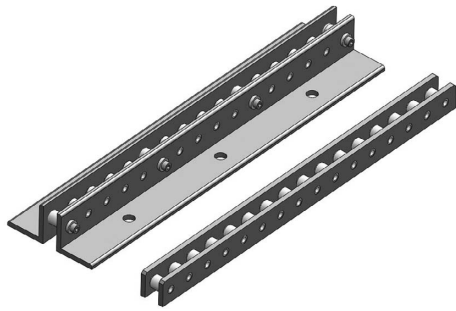

Flat (FR)

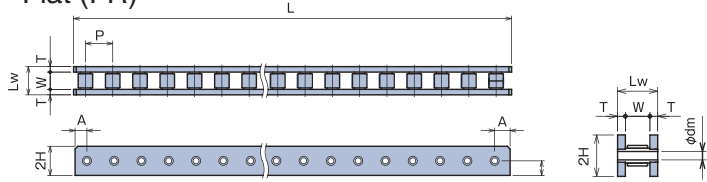

Angled (AR)

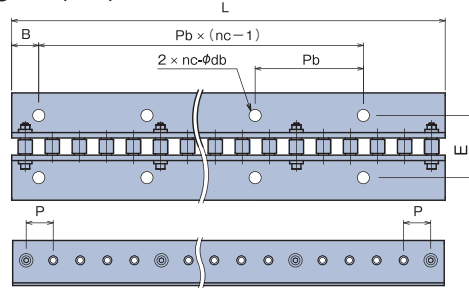

*The hollow pins in angled models need to be fixed to the rack by bolts and nuts.

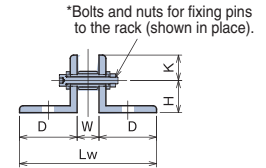

Model Numbering Example

PDU55 - FR - 18P

Frame no. P D U : Standard Series
 P D U S : S Series

No. of rollers FR : Flat
 AR : Angled

Pin rack 18P

Flat Type Specifications Table

Specifications	Frame model	Pitch P	Set Length		Frame Thickness T	Pin Position A	Inner Width W	Total Width Lw	Total Height 2H	Bolt Bore Dia. ϕ_{db}	Mounting Bolt Size	Mass kg	Minimum Available Length	
			Total length L	No. of rollers NT									Total length L	No. of rollers NT
Standard Series	PDU20	20	800	40	4.5	10	12	21	22	4.5	M4	1.5	160	8
	PDU22	22	792	36	4.5	11	16	25	25	4.5	M4	1.8	286	13
	PDU30	30	780	26	6	15	19	31	32	6.5	M6	3.0	300	10
	PDU35	35	770	22	9	17.5	22	40	38	9	M8	5.0	280	8
	PDU40	40	800	20	9	20	28	46	45	10.8	M10	6.4	280	7
	PDU50	50	1000	20	12	25	28	52	65	12.8	M12	14.0	300	6
	PDU55	55	990	18	12	27.5	36	60	65	12.8	M12	14.9	495	9
	PDU70	70	980	14	16	35	40	72	75	17	M16	22.2	420	6
	PDU80	80	960	12	16	40	42	74	90	17	M16	26.3	560	7
	PDU90	90	990	11	19	45	52	90	100	22	M20	36.5	540	6
PDU120	120	960	8	22	60	68	112	150	32	M30	60.7	480	4	
S Series	PDUS20	20	800	40	5	10	12	22	22	4.5	M4	1.6	160	8
	PDUS22	22	792	36	5	11	16	26	25	4.5	M4	2.0	286	13
	PDUS30	30	780	26	6	15	19	31	32	6.5	M6	3.1	300	10
	PDUS35	35	770	22	6	17.5	22	34	38	9	M8	3.7	280	8
	PDUS40	40	800	20	8	20	28	44	50	10.8	M10	6.5	280	7
	PDUS50	50	1000	20	9	25	28	46	65	12.8	M12	11.1	300	6
	PDUS55	55	990	18	9	27.5	36	54	65	12.8	M12	12.1	495	9
	PDUS70	70	980	14	10	35	40	60	75	17	M16	15.6	420	6
	PDUS80	80	960	12	12	40	42	66	90	17	M16	21.3	560	7
	PDUS90	90	990	11	12	45	52	76	100	22	M20	26.2	540	6

*Racks with numbers of rollers besides those listed are available.

Angled Type Specifications

Specifications	Frame model	Pitch P	Set Length		Inner Width W	Total Width Lw	Angled Leg Width D	Center Height		Mounting Hole Position					Mounting Bolt Size	Mass kg	Minimum Available Length		
			Total length L	No. of rollers NT				H	K	Width E	End width B	Pitch Pb	Mounting hole spacing $Pb \times nc$	No. of holes (one side) nc			Bore dia. ϕ_{db}	Total length L	No. of rollers NT
Standard Series	PDU20	20	800	40	12	72	30	20	10	56	20	120	720	7	9	M8	2.4	160	8
	PDU22	22	792	36	16	96	40	27	13	60	22	88	704	9	11	M10	3.3	132	6
	PDU30	30	780	26	19	119	50	28	22	69	30	120	720	7	13.5	M12	5.9	180	6
	PDU35	35	770	22	22	122	50	30	20	76	35	140	700	6	13.5	M12	7.7	210	6
	PDU40	40	800	20	28	128	50	28	22	88	40	120	720	7	13.5	M12	8.5	320	8
	PDU50	50	1000	20	28	158	65	40	25	104	50	150	900	7	17.5	M16	17.1	250	5
	PDU55	55	990	18	36	166	65	37	28	112	55	165	825	6	17.5	M16	18.0	440	8
	PDU70	70	980	14														560	8
	PDU80	80	960	12														480	6
	PDU90	90	990	11														540	6
PDU120	120	960	8														480	4	
Contact a Tsubaki representative for details.																			
S Series	PDUS20	20	800	40	12	72	30	20	10	56	20	120	720	7	9	M8	2.4	160	8
	PDUS22	22	792	36	16	96	40	27	13	60	22	88	704	9	11	M10	3.4	132	6
	PDUS30	30	780	26	19	119	50	28	22	69	30	120	720	7	13.5	M12	6.6	180	6
	PDUS35	35	770	22	22	122	50	30	20	76	35	140	700	6	13.5	M12	6.8	210	6
	PDUS40	40	800	20	28	128	50	28	22	88	40	120	720	7	13.5	M12	7.5	320	8
	PDUS50	50	1000	20	28	158	65	40	25	104	50	150	900	7	17.5	M16	13.8	250	5
PDUS55	55	990	18	36	166	65	37	28	112	55	165	825	6	17.5	M16	14.8	440	8	

Note:

1. Long length pin racks are constructed as either "set length x no. of rollers" or "set length x no. of rollers + no. of rollers less than set length." Contact a Tsubaki representative regarding special numbers of rollers.
2. No mounting bolts are provided.

Pin Gear Drive Unit Selection Guide

Pin Gear Models and Specifications

Model Numbering Example

PDU90 - S - 1B 24T

Frame model
P D U : Standard Series
PDU S : S Series

Pin gear
G : Outer drive
N : Inner drive
S : Linear drive

No. of teeth
Hub type
1B : B type
1C : C type

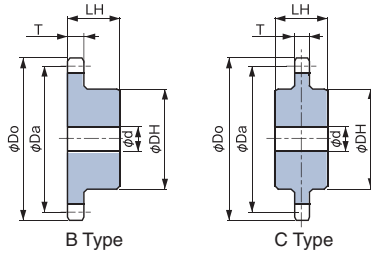

	Standard Series	S Series
Material	Machine structural use carbon steel	Stainless steel
Configuration	B and C types	
Tooth hardening	Induction hardened and tempered	None

*Other materials available.
*Shaft bore finishing available.
*Lock pin gear specifications (with a frictional locking mechanism) available. (See the diagram below.)

Pin Gear Applicable Number of Teeth Range (for both Standard and S Series)

No. of Teeth NT	Linear Rack	Outer Drive Pin Wheel Number of Rollers								Inner Drive Pin Wheel Number of Rollers							
		60	70	80	100	150	200	250	300	60	70	80	100	150	200	250	
11	×	×	×	×	×	×	×	×	×	○	○	○	○	×	×	×	
12	△	×	×	×	×	×	×	×	×	○	○	○	○	○	○	○	
13	○	×	×	×	×	×	△	△	△	○	○	○	○	○	○	○	
14	○	×	×	△	△	△	△	△	△	○	○	○	○	○	○	○	
15	○	△	△	△	△	△	△	△	△	○	○	○	○	○	○	○	
16	○	△	△	△	△	△	△	△	△	○	○	○	○	○	○	○	
17	○	△	△	△	△	△	△	△	△	○	○	○	○	○	○	○	
18	○	△	△	△	△	△	△	△	△	○	○	○	○	○	○	○	
19	○	△	△	△	△	△	△	△	△	○	○	○	○	○	○	○	
20	○	△	△	△	△	△	△	△	△	○	○	○	○	○	○	○	
21	○	△	△	△	△	△	△	△	△	○	○	○	○	○	○	○	
22	○	△	△	△	△	△	△	△	△	○	○	○	○	○	○	○	
23	○	△	△	△	△	△	△	△	△	○	○	○	○	○	○	○	
24 and more	○	○	○	○	○	○	○	○	○	○	○	○	○	○	○	○	

○ : Permissible
△ : Tangential load may decrease depending on usage conditions. Contact a Tsubaki representative for more information.
× : Not allowed (due to an insufficient engagement factor)

Pin Gear Specifications Chart (for both Standard and S Series)

Frame No.	PDU (S) 20						PDU (S) 22						PDU (S) 30						PDU (S) 35					
	Pitch P		20				Pitch P		22				Pitch P		30				Pitch P		35			
	Roller dia. (ref.)		10.16				Roller dia. (ref.)		11.91				Roller dia. (ref.)		15.88				Roller dia. (ref.)		19.05			
	Tooth width T		9				Tooth width T		12				Tooth width T		15				Tooth width T		18			
No. of Teeth NT	Pitch Dia. Da	Outer Dia. Do	Pilot Bore Dia. d	Hub Dia. DH	Hub Length LH	Pitch Dia. Da	Outer Dia. Do	Pilot Bore Dia. d	Hub Dia. DH	Hub Length LH	Pitch Dia. Da	Outer Dia. Do	Pilot Bore Dia. d	Hub Dia. DH	Hub Length LH	Pitch Dia. Da	Outer Dia. Do	Pilot Bore Dia. d	Hub Dia. DH	Hub Length LH				
11	72.43	85	12.7	43	20	80.03	95	12.7	45	30	108.44	129	15.9	65	50	126.55	151	23	75	80				
12	78.59	91	12.7	49	20	86.83	102	12.7	50	40	117.79	138	19.0	75	50	137.49	162	23	85	80				
14	91.13	105	12.7	50	30	100.44	115	15.9	60	40	136.49	157	19.0	80	50	159.57	184	23	110	90				
16	103.66	116	12.7	50	30	114.05	129	15.9	70	40	155.39	176	19.0	80	60	181.65	206	28	120	100				
18	116.19	129	12.7	60	30	127.85	143	15.9	70	50	174.29	194	19.0	90	60	203.74	228	28	120	100				
20	128.72	141	12.7	60	30	141.66	157	15.9	70	50	192.99	213	23.0	90	70	225.82	250	28	130	100				
22	141.46	154	15.9	60	40	155.66	171	15.9	70	50	212.08	232	23.0	90	70	247.90	272	33	130	110				
24	153.99	167	15.9	60	40	169.47	184	18.0	70	50	230.98	251	23.0	100	70	269.58	294	33	130	110				

Frame No.	PDU (S) 40						PDU (S) 50						PDU (S) 55						PDU (S) 70					
	Pitch P		40				Pitch P		50				Pitch P		55				Pitch P		70			
	Roller dia. (ref.)		22.23				Roller dia. (ref.)		25.4				Roller dia. (ref.)		28.58				Roller dia. (ref.)		35.71			
	Tooth width T		24				Tooth width T		24				Tooth width T		30				Tooth width T		34			
No. of Teeth NT	Pitch Dia. Da	Outer Dia. Do	Pilot Bore Dia. d	Hub Dia. DH	Hub Length LH	Pitch Dia. Da	Outer Dia. Do	Pilot Bore Dia. d	Hub Dia. DH	Hub Length LH	Pitch Dia. Da	Outer Dia. Do	Pilot Bore Dia. d	Hub Dia. DH	Hub Length LH	Pitch Dia. Da	Outer Dia. Do	Pilot Bore Dia. d	Hub Dia. DH	Hub Length LH				
11	145.66	174	28	90	80	181.47	214	33	100	90	200.18	237	33	120	140	252.30	298	43	157	150				
12	157.79	186	28	100	90	196.59	229	33	110	100	216.08	253	33	135	140	273.98	320	43	170	160				
14	182.65	211	28	120	100	227.62	260	33	130	110	250.30	287	33	160	140	317.94	364	43	180	160				
16	207.72	236	33	120	100	259.05	292	33	140	120	284.91	322	33	170	150	362.11	408	43	190	160				
18	232.58	261	33	130	100	290.48	323	33	140	130	319.53	356	33	170	160	406.07	452	43	190	170				
20	257.85	286	33	130	110	321.91	354	33	150	140	354.14	391	33	180	160	450.43	496	43	200	190				
22	283.31	312	33	140	120	353.74	386	33	150	140	389.15	426	38	180	160	495.00	541	63	210	190				
24	308.18	337	33	140	120	384.97	417	33	160	140	423.57	460	38	190	170	538.76	585	63	210	190				

Frame No.	PDU (S) 80						PDU (S) 90						PDU120					
	Pitch P		80				Pitch P		90				Pitch P		120			
	Roller dia. (ref.)		39.68				Roller dia. (ref.)		47.63				Roller dia. (ref.)		63.5			
	Tooth width T		36				Tooth width T		45				Tooth width T		60			
No. of Teeth NT	Pitch Dia. Da	Outer Dia. Do	Pilot Bore Dia. d	Hub Dia. DH	Hub Length LH	Pitch Dia. Da	Outer Dia. Do	Pilot Bore Dia. d	Hub Dia. DH	Hub Length LH	Pitch Dia. Da	Outer Dia. Do	Pilot Bore Dia. d	Hub Dia. DH	Hub Length LH			
11	288.11	339	43	180	150	325.13	387	43	210	180	435.17	517	63	250	240			
12	312.78	364	43	190	160	352.77	414	43	220	190	472.37	554	63	260	240			
14	363.11	414	43	200	180	409.07	470	43	230	210	546.76	629	63	270	250			
16	413.64	465	43	210	200	465.97	527	63	240	230	621.15	703	63	280	260			
18	463.97	515	43	220	200	522.66	584	63	250	250	696.95	779	63	290	280			
20	514.50	566	63	230	200	579.56	641	63	260	250	772.54	855	68	300	300			
22	565.43	617	63	230	210	636.85	698	63	270	260	848.94	931	68	310	320			
24	615.55	667	63	240	230	692.95	754	63	270	260	923.73	1006	68	320	320			

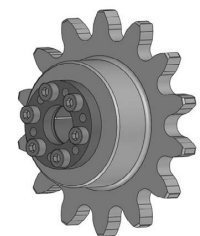

Lock Pin Gear Series

*Pin gear tooth profiles may change depending on the application (outer drive, inner drive, linear drive).

Before Use
Standard Roller Chains
Lube-Free Roller Chains
Heavy Duty Roller Chains
Corrosion Resistant Roller Chains
Specialty Roller Chains
Sprockets
Pin Gear Drives
Accessories
Selection
Handling

Pin Gear Drive Unit Selection and Installation

Selection Guide

1. Provisionally select pin gear drive unit pitch diameter

- **For rotating movement** : Provisionally select the pitch diameter of the pin wheel from the size of the rotating equipment. Provisionally select the pitch diameter of the pin gear from the reduction ratio.
- **For linear movement** : Provisionally select the pitch diameter of the pin gear from the equipment layout.

2. Calculate tangential load Fw of the load

Calculate tangential load Fw of the load acting on the pin wheel or pin rack from the load conditions.

3. Calculate corrected tangential load Ft

Find the usage factor Ks (Table 1) from the operating conditions and the speed factor Kv (Table 2) from the tangential speed and determine the corrected tangential load Ft by multiplying the above with the tangential load Fw of the load.

$$F_t = K_s \times K_v \times F_w$$

4. Select the pin gear drive unit frame model

Select a pin gear drive unit frame model that satisfies the conditions below from the allowable tangential load Fp and the corrected tangential load Ft of each pin rack or pin wheel frame model.

$$\text{Allowable tangential load } F_p > \text{Corrected tangential load } F_t$$

5. Select the model number

- **Pin wheel** : Select the number of rollers of the pin wheel with a pitch diameter closest to the pitch diameter of the pin wheel provisionally selected and the selected frame model.
- **Pin rack** : Find the number of rack rollers from the selected frame model and the running distance (or the stroke distance).
- **Pin gear** : Select the number of teeth of the pin gears with a pitch diameter closest to the pitch diameter of the pin gear provisionally selected and the selected frame model.

Note: There are limits to the range of the number of pin gear teeth usable. (See the table on pg. 150.) Reselect the number of teeth if insufficient.

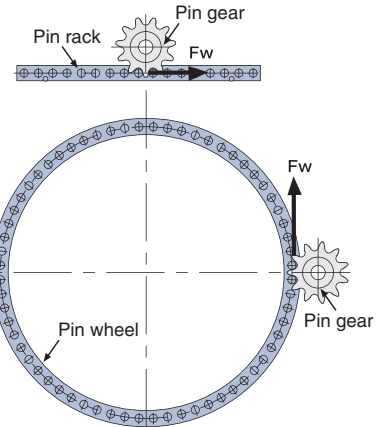

Usage Factor Ks (Table 1)

Operating Conditions	Hours of Operation per Day		
	Less than 3	Less than 12	24 Hours/Day
Continuous smooth transmission	1.0	1.1	1.2
Continuous impact load	1.2	1.3	1.5
Intermittent unidirectional operation	1.3	1.5	1.7
Intermittent forward - reverse operation	1.5	1.7	2.2
Continuous forward - reverse operation	1.8	2.0	2.5

Speed Factor Kv (Table 2)

Tangential Speed m/min								
0	10	15	20	25	30	35	40	50
1.02	1.04	1.05	1.06	1.06	1.07	1.08	1.1	1.2

Note : 1. Allowable tangential speed for all frame models is 50m/min.
2. There are limits to the range of the number of pin gear teeth usable. Reselect the number of teeth if insufficient.

Installation Precision

Pin wheel : The protruding surface of the pin wheel frame has been machined to be concentric with the roller mounting holes. The frame acts as a centering reference plane, allowing it to be mounted by press fitting it into the centering section of the equipment. The precision of the equipment's centering section should be finished as per the Centering Section Precision table below.

Pin rack : Calculate the parallelism between equipment beforehand so that the parallelism between the installation reference plane on the pin rack side and the pin gear center fall within the Gear Center Parallelism table below.

Install the pin rack so that the positions of A and B on both connecting elements fall within the table below.

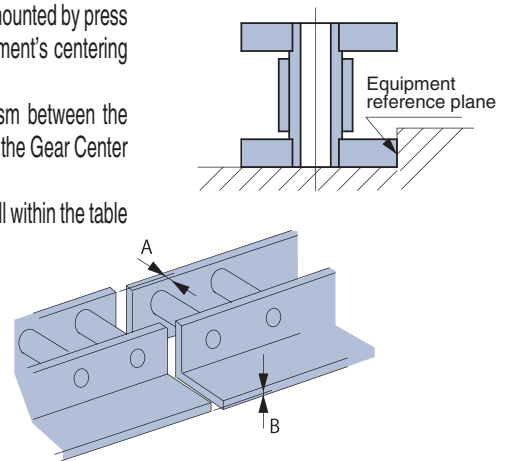
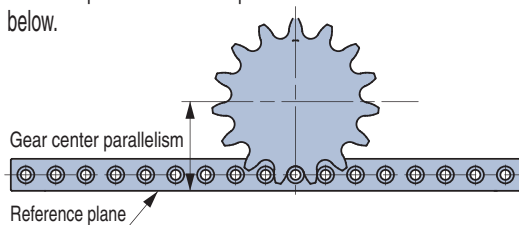

*Read all appropriate instructions before mounting.

Frame Model		PDU20 PDU20	PDU22 PDU22	PDU30 PDU30	PDU35 PDU35	PDU40 PDU40	PDU50 PDU50	PDU55 PDU55	PDU70 PDU70	PDU80 PDU80	PDU90 PDU90	PDU120
Rotating Drive	Centering section precision (mm)	0.3	0.3	0.4	0.5	0.6	0.7	0.8	0.9	1.0	1.2	1.6
	Gear center parallelism (mm)	0.3	0.3	0.4	0.5	0.6	0.7	0.8	0.9	1.0	1.2	1.6
Linear Drive	Connecting element positioning A·B (mm)	0.1	0.2	0.2	0.3	0.3	0.4	0.4	0.5	0.5	0.6	0.8

Accessories (Peripheral Instruments)

Chain Tensioners

The Tsubaki Chain Tensioner adjusts slackness in the chain to enable continuous and proper chain operation.

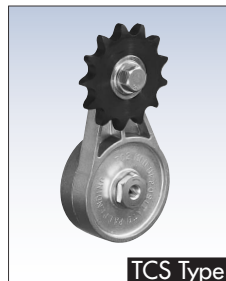

TCS Type

Automatic Lubricator for Roller Chain

1. Operational period can be freely set
2. Reduces maintenance time
3. Lightweight, compact
4. Can be installed in any direction
5. Waterproof
6. Includes an inspection window
7. Highly safe
8. Reliable



Automatic Lubricator for Roller Chain

Chain Cutting Tools

These tools enable chains to be cut to the desired length.



Chain Vise



Punch

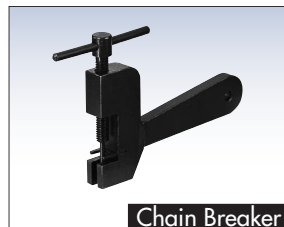

Chain Breaker

End Fixtures

The end fitting bolts and end fitting bolt connecting links are designed to be stronger than those of RS Roller Chains.



End Fitting Bolt



End Fitting Bolt Connecting Link

Chain Connecting Tools

This tool pulls the two ends of the chain together when installing the chain on a machine.

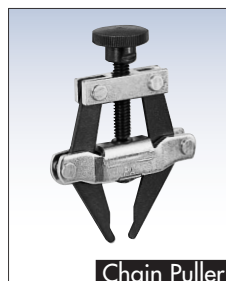

Chain Puller

Chain Elongation Scale

Allows quick checks of pitch elongation limit.



Chain Elongation Scale

Chain Tensioners

Slackness in the chain can cause chain vibration and noise, and improper engagement with the sprocket, as well as preventing the chain from operating properly. The Tsubaki Chain Tensioner adjusts slackness in the chain to enable continuous and proper chain operation.

There are four types of Tsubaki Chain Tensioners: Our new TH Type (straight type, with idler sprocket), the TCS Type (swing type, with idler sprocket), the ETS Type (straight type, with idler sprocket), and the TA Type (straight type, with plastic shoe).

Construction

Main unit

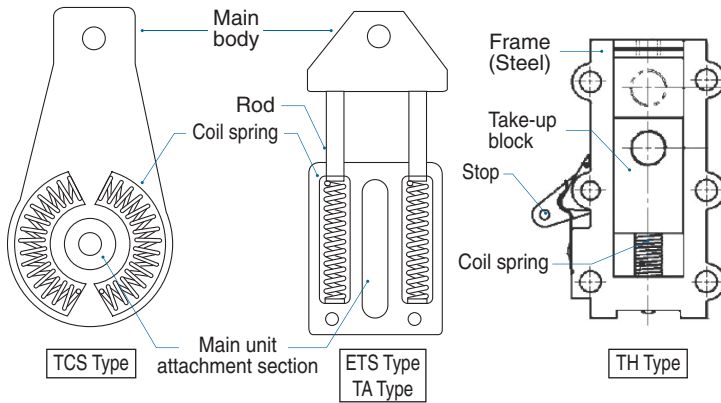

The Tsubaki Chain Tensioner is composed of a main unit and an idler sprocket. (The TA Type is a unitized construction with plastic shoe.) The tensioner's main unit employs the elasticity of a built-in coil spring to tension.

TA Type main unit attachment bolt Table 1

Model Number	Main Unit Attachment Bolt	Model Number	Main Unit Attachment Bolt
CT-TA40	M10	CT-TA60	M12
CT-TA50	M12	CT-TA80	M14

Note: Tensioner attachment bolt not included with tensioner.

Idler sprocket

The idler sprocket is composed of a sprocket with a built-in bearing, (TH Type provided with a lube-free bush upon request) an attachment bolt, and a washer. The sprocket teeth undergo induction hardening. TCS and ETS Types are given a black coating, while TH Type is plated.

TCS/ETS Types

Table 2

Model Number	Sprocket No. of Teeth	Sprocket Mounting Bolt				Flat Washer		Tensioner Mounting Bolt
		Size	Length	Strength Classification	Quantity	Nominal	Quantity	
CT-TCS40	17	M10	30	10.9	1	10	2	M10
CT-ETS40			35					
CT-TCS50	15	M10	30	10.9	1	10	2	M10
CT-ETS50			35					
CT-TCS60	13	M12	35	10.9	1	12	2	M12
CT-ETS60			45					
CT-TCS80	11	M12	35	10.9	1	12	4	M12
CT-ETS80			45					

TH Type

Table 3

Model Number	Applicable Size	Sprocket No. of Teeth	Sprocket Mounting Bolt	
			Size	Length
CT-TH1	RS35-1	20	M12	45
	RS40-1	15		
CT-TH2	RS50-1	15	M12	55
	RS60-1	14		
	RS80-1	11		

TCS and ETS Type Assembly

Remove the main unit of the TCS or ETS Type tensioner, the idler sprocket, attachment bolt and washers from their packaging, and assemble them as shown in Fig. 1. The plastic shoe for the TA type comes as part of the main unit and no assembly is required. One flat washer should be installed on each side of the idler sprocket. However, the CT-TCS80 and CT-ETS80 should have two washers installed on each side. The idler sprocket attachment bolt and flat washers are included with the idler sprocket.

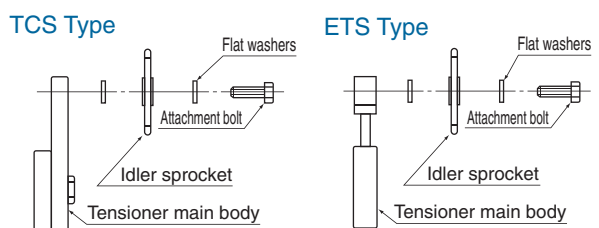

Fig. 1 Chain tensioner assembly

Bolt Tightening Torque

When installing the tensioner on a base after attaching the idler sprocket to the tensioner, be sure to fasten the idler sprocket and the tensioner securely with a bolt. The table on the right indicates the tightening torque. Be sure to use bolts with a strength classification of 8.8T or more.

Checking the rotation of the idler sprocket

If the idler sprocket is anchored in place, check whether or not the sprocket can turn smoothly. If it does not turn smoothly, the bolt may be too tight. Loosen the bolt and then retighten properly.

Position adjustment

When setting the tensioner, adjust with a shim so that the center of the idler sprocket and chain are aligned.

Attachment bolt locking torque Unit: kN·m{kgf·m} Table 4

	Idler sprocket attachment bolt	Tensioner attachment bolt
CT-TCS40,50	0.02{2.0}	0.04{4.0}
CT-TCS60,80	0.03{3.0}	0.05{5.0}
CT-ETS40,50	0.03{3.0}	0.03{3.0}
CT-ETS60,80	0.04{4.0}	0.04{4.0}
CT-TA40	—	0.03{3.0}
CT-TA50,60	—	0.04{4.0}
CT-TA80	—	0.05{5.0}

★ Refer to Tables 1 and 2 for bolt size.

Chain Tensioners

Product type

1 TCS Type: Swing type, with idler sprocket

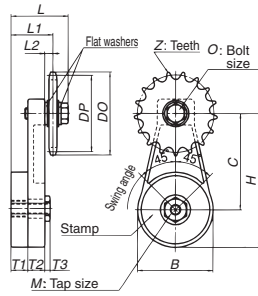

■ **Ordering** Indicate the code (product code and model number).

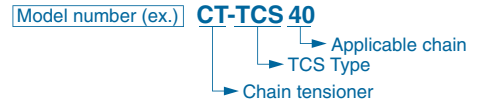

■ **Ordering Example**

Produce code	Model number	Quantity	Unit (pcs)
D210001	CT-TCS40	1	K

■ Operating temperature : -10°C to 100°C

Note 1. Only the CT-TCS80 has two washers installed on each side.
2. The swing angle of CT-TCS60 and CT-TCS80 is 30°.

Produce code	Model Number	Stamp	Applicable Chain	B	C	H	M	T ₁	T ₂	T ₃	Z	DP	DO	O	L	L ₁	L ₂	Plunge Force kN{kgf}	Approximate Mass kg/unit
D210001	CT-TCS40	TC-1	RS40-1	69	87.5	122	M10	15.5	15.5	5	17	69.12	75	M10	50.5	37.5	6.5	0{0}~0.15{15}	0.74
D210002	CT-TCS50	TC-1	RS50-1	69	87.5	122	M10	15.5	15.5	5	15	76.35	83	M10	50.5	37.5	6.5	0{0}~0.15{15}	0.82
D210003	CT-TCS60	TC-2	RS60-1	90	100	145	M12	18	18	7	13	79.60	88	M12	60.5	44.5	8.5	0{0}~0.39{40}	1.30
D210004	CT-TCS80	TC-2	RS80-1	90	100	145	M12	18	18	7	11	90.16	101	M12	65.5	47	11	0{0}~0.39{40}	1.52

Note: All models stocked.

2 ETS Type: Straight type, with idler sprocket

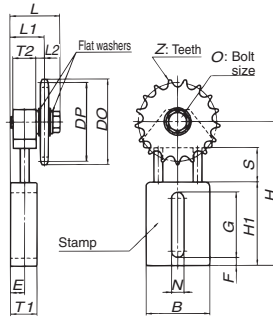

■ **Ordering** Indicate the code (product code and model number).

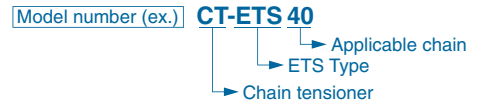

■ **Ordering Example**

Produce code	Model number	Quantity	Unit (pcs)
D210005	CT-ETS40	1	K

■ Operating temperature : -10°C to 100°C

Note: Only the CT-ETS80 has two washers installed on each side.

Produce code	Model Number	Stamp	Applicable Chain	S	H	H ₁	F	G	B	N	T ₁	T ₂	E	Z	DP	DO	O	L	L ₁	L ₂	Plunge Force kN{kgf}	Approximate Mass kg/unit
D210005	CT-ETS40	TO-1	RS40-1	30	129	74	7	58	56.2	11	23	20	12.5	17	69.12	76	M10	42	29	6.5	0.10{10}~0.25{25}	0.60
D210006	CT-ETS50	TO-1	RS50-1	30	129	74	7	58	56.2	11	23	20	12.5	15	76.35	84	M10	42	29	6.5	0.10{10}~0.25{25}	0.69
D210007	CT-ETS60	TO-2	RS60-1	38	163	87	9	70	70.5	12.5	28	25	15	13	79.60	89	M12	52	36	8.5	0.15{15}~0.39{40}	1.15
D210008	CT-ETS80	TO-2	RS80-1	38	163	87	9	70	70.5	12.5	28	25	15	11	90.16	102	M12	57	38.5	11	0.15{15}~0.39{40}	1.37

Note: All models stocked.
Lubricate the rod section regularly.

3 TA Type: Straight type, with plastic shoe

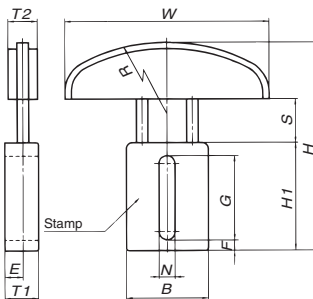

■ **Ordering** Indicate the code (product code and model number).

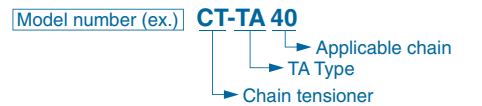

■ **Ordering Example**

Produce code	Model number	Quantity	Unit (pcs)
D210009	CT-TA40	1	K

■ Operating temperature : -10°C to 60°C

Produce code	Model Number	Stamp	Applicable Chain	S	H	H ₁	F	G	B	N	T ₁	E	W	R	T ₂	Plunge Force kN{kgf}	Approximate Mass kg/unit
D210009	CT-TA40	TO-1	RS40-1	30	143	74	7	58	56.2	11	23	12.5	140	120	20	0.10{10}~0.25{25}	0.39
D210010	CT-TA50	TO-2	RS50-1	38	164	87	9	70	70.5	12.5	28	15	140	140	22	0.15{15}~0.39{40}	0.65
D210011	CT-TA60	TO-2	RS60-1	38	164	87	9	70	70.5	12.5	28	15	140	140	22	0.15{15}~0.39{40}	0.65
D210012	CT-TA80	TO-3	RS80-1	44	187	104	9	86	82	14.5	33	17.5	140	160	25	0.29{30}~0.59{60}	0.99

Note: All models stocked.
Lubricate the rod section regularly.

Chain Tensioners

4 TH Type: Straight type, with idler sprocket

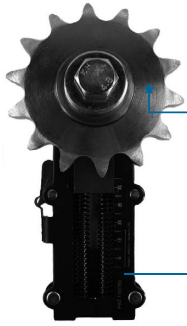

Choose your idler sprocket



Ball bearing type (Standard type)



Lube-free bush type (Optional type)

Unique ratchet and spring construction

The spring automatically controls chain sag and excessive vibration. The ratchet construction makes installation a snap.

CT-TH1 : For RS35-1 and RS40-1
CT-TH2 : For RS50-1, RS60-1, and RS80-1

Dimensions

Main Body

CT-TH1

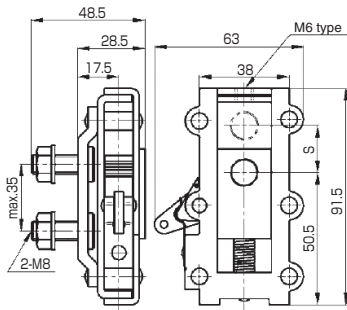

**"S" indicates "stroke."

CT-TH2

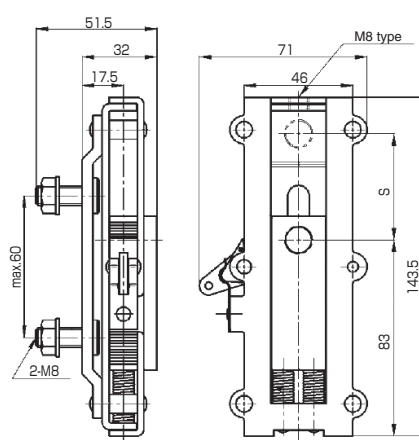

Adapter (fixed washer)

CT-THS1

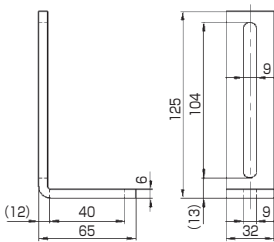

CT-THS2

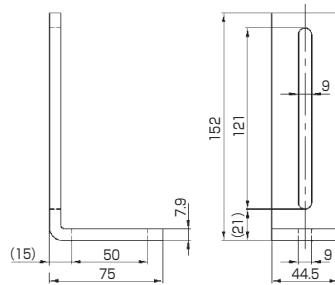

Idler Sprocket

Ball Bearing Type

Lube-free Bush Type

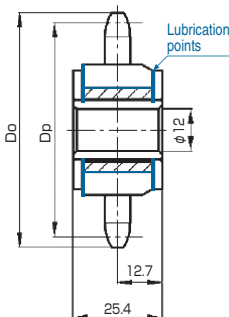
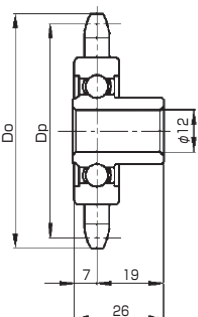

Ordering

Indicate the code (product code and model number).

Model number

Main body/ adapter

CT-TH 1

Chain tensioner
Tensioner body size
TH: TH Type tensioner
THS: TH Type tensioner adapter

Idler sprocket

RS35-THB 20T

Applicable chain size
Idler sprocket no. of teeth
THB: Ball bearing type
THL: Lube-free bush type

Ordering Example

Produce code	Model number	Quantity	Unit (pcs)
G651001	CT-TH1	1	K
G652000	RS35-THB20T	1	K
G651003	CT-THS1	1	K

Product Code	Model Number	Stroke S (mm)	Plunge Force (N)	
			Min.	Max.
G651001	CT-TH1	25	39.2	117.6
G651002	CT-TH2	45	98.0	294.0

Each package will contain the following.

Contains	Dimensions	CT-TH1	CT-TH2
Hexagonal Bolt	M12×45L	1	—
	M12×55L	—	1
Hexagonal Screw	M6×35L	1	—
	M8×55L	—	1
Round Head Screw	M8×23L	2	2
Hex Key		1	1
Spacer	Thickness: 3mm	1	3

Product Code	Model Number	Chain Tensioner
G651003	CT-THS1	CT-TH1
G651004	CT-THS2	CT-TH2

	Product Code	Model Number	Idler No. of Teeth	Pitch Diameter (Dp)	Outer Diameter (Do)	Max. RPM	Allowable Bearing Load (N)
Ball Bearing Type	G652000	RS35-THB20T	20	60.89	66	3000	3300
	G652010	RS40-THB15T	15	61.08	67		
	G652020	RS50-THB15T	15	76.35	84		
	G652030	RS60-THB14T	14	85.61	95		
	G652040	RS80-THB11T	11	90.16	102		
Lube-free Bush Type	G652001	RS35-THL20T	20	60.89	66	2500	343
	G652011	RS40-THL15T	15	61.08	67		
	G652021	RS50-THL15T	15	76.35	84		
	G652031	RS60-THL14T	14	85.61	95		

*Thoroughly lubricate sliding areas of lube-free bush type idler sprockets before use.

Chain Tensioners

Installation

Attaching the TCS type tensioner

- 1) Attach the roller chain to the drive and driven sprockets.
- 2) In order to attach the tensioner to the slack side of the roller chain as shown in Fig. 2, first push in on the roller chain with the idler sprocket and determine the attachment position (bolt hole) for the tensioner.

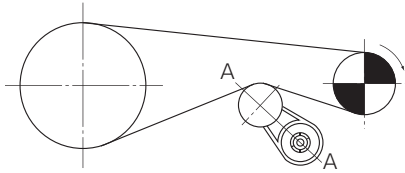

Fig. 2 Tensioner position (front)

- 3) Then, within a range where the roller chain does not contact the tensioner unit, ensure the force of the roller chain moves as perpendicular as possible to the A-A line. (Tensioner is a swing type unit.)

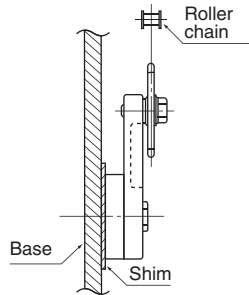

Fig. 3 Tensioner position (side)

- 4) Adjust with a shim, as shown in Fig. 3, so that the center of the roller chain and idler sprocket are aligned.

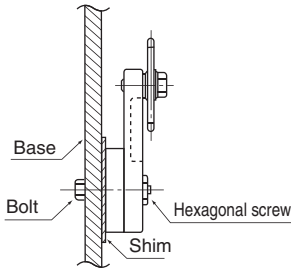

Fig. 4 Tightening the tensioner

- 5) Open a hole in the base that holds the tensioner. (A slotted hole is convenient.)

- 6) Push in on the chain with the tensioner and temporarily tighten the tensioner to the base with a bolt. (Fig. 4)

Then tighten the hexagonal screw and anchor so that the swing angle is about 15°.

- 7) Perform a test operation and check whether the tensioner works properly. If any of the following occurs, reset the tensioner.

- Contacts the side of the idler sprocket: Not centered properly
- Vertical or traverse vibration: Insufficient initial tension
- Increased noise: Excessive initial tension

TH Type Tensioner Installation

- 1) Always insert the spacer where indicated (positions A & B) as shown in Dia. 8 when installing the idler sprocket on the tensioner. (Failure to insert the spacer will result in tensioner contact with the roller chain. See Table 5.)

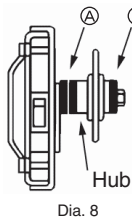

Dia. 8

Attach the hub so that it faces the tensioner when installing ball bearing type idler sprockets. When attaching on the opposite side, install the number of spacers indicated in parentheses in Table 5.

- 2) The tensioner stop should be positioned facing down (spring facing down) as per the diagram on the left.

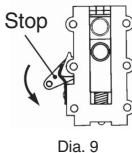

Dia. 9

- 3) Once the round head bolts are attached to the tensioner as shown, attach the adapter and tighten the nuts just until snug.

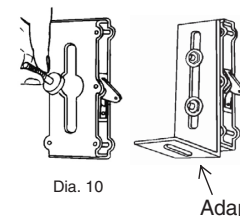

Dia. 10

Caution: Always install chain tensioners on the roller chain sag side. Tensioners cannot be installed on the tension side or used when the chain is run backwards.

Attaching the ETS and TA Type tensioners

- 1) Push in on the roller chain with the tensioner's idler sprocket (Fig. 5) and determine the position of the hole on the attachment base.

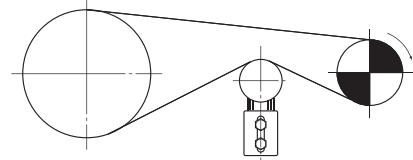

Fig. 5 Tensioner position (front)

- 2) Open a hole in the attachment base. In this case, two bolt holes are required, but a hole that is as long as possible will make positioning simpler, and the re-tensioning operation will be easier when the chain elongates.

- 3) Temporarily tighten the tensioner with two bolts. At this time, adjust with a shim, etc., so that the center of the idler sprocket and roller chain are aligned. (Fig. 6)

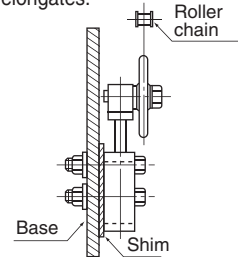

Fig. 6 Tightening the tensioner

- 4) Push in on the chain with the tensioner and, if the amount of slack is appropriate (δ), tighten the nut and anchor the tensioner. Aim for a value less than $\delta = 0.02 \times L$. (Fig. 7)

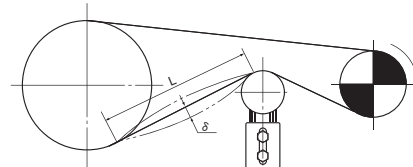
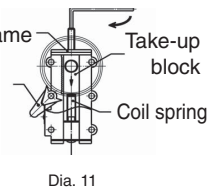

Fig. 7 Tensioner's anchored position

- 5) Perform a test operation and check whether the tensioner works properly. If any of the following occurs, reset the tensioner.

- Contacts the side of the idler sprocket: Not centered properly
- Vertical or traverse vibration: Insufficient initial tension
- Increased noise: Excessive initial tension

- 4) Attach a hexagonal screw to the tap hole on the end of the tensioner. Use the hex key to tighten the screw, and push the take-up block down as far as possible. (Caution: Failure to perform action 2) above will prevent the take-up block from being pushed down.)



Dia. 11

- 5) Once the drive and driven sprockets have been aligned, fix the adapter to the attachment area using a mounting bolt ("C" in diagram, bolt not included).

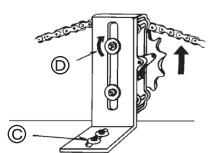

- 6) Once the chain is engaging the sprocket, tighten the adapter mounting nuts ("D" in diagram). Next, after inverting the tensioner stop as shown by the arrow in Dia. 9, removing the hexagonal screw will activate the spring. Installation is now complete. Check the condition of the roller chain sag and the installation itself.

Number of Spacers Table 5

Idler Sprocket		Number of Spacers	
Type	Model Number	"A" side in Dia. 8	"B" side in Dia. 8
Ball Bearing	RS35-THB20T	0 (1)	1 (0)
	RS40-THB15T	0	1
	RS50-THB15T	0 (3)	3 (0)
	RS60-THB14T	0	3
	RS80-THB11T	2	1
Lube-free Bush	RS35-THL20T	0	1
	RS40-THL15T	1	0
	RS50-THL15T	2	1
	RS60-THL14T	3	0

Chain Cutting Tools

Tsubaki provides roller chains in either unit lengths (3048 mm) or reels. The following tools are available for cutting the chain to a desired length. See "Roller Chain and Sprocket Handling" for use.

1 Chain Vise

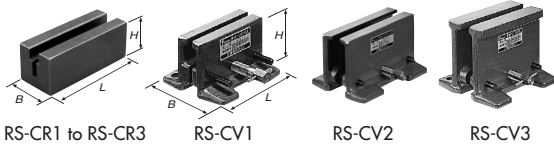

Model Number	Applicable Chain			Dimensions		
	Single-strand	Double-strand	Triple-strand	L	H	B
RS-CR1	RS15	—	—	50	16.4	20
RS-CR2	RS25	—	—	50	19	20
RS-CR3	RS35	—	—	60	30	30
RS-CV1	RS40 - 80	RS40	—	100	65	94 - 115
RS-CV2	RS40 - 160	RS40 - 100	RS40 - 100	180	110	120 - 151
RS-CV3	RS80 - 240	RS80 - 160	RS80 - 100	200	170	180 - 220

2 Punch

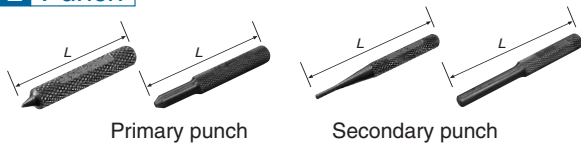

Model Number				Applicable Chain
Primary punch	L	Secondary punch	L	
RS-P11	52	RS-P21	65	RS15
		RS-P22	70	RS25
		RS-P23	80	RS35
RS-P14	60	RS-P24	80	RS40 - 60
RS-P15	70	RS-P25	90	RS80 - 120
RS-P16	80	RS-P26	120	RS140 - 240

Note: 1. The RS-P11 can be used with three sizes: RS15, RS25, and RS35.

Model Number	L	Applicable Chain
Rivet punch		
RS-RP01	100	RS40
RS-RP02	100	RS50
RS-RP03	100	RS60
RS-RP04	100	RS80

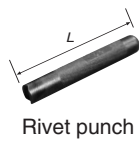

Rivet punch

3 Chain Breakers



Model Number	L	Applicable Chain (Single-strand)	Model Number	L	Applicable Chain (Single-strand & Double-strand)
RS-CS-A1	116	RS25	RS-CS-B1	185	RS40 - 60
RS-CS-A2	119	RS35	RS-CS-C1	222	RS80 , 100
RS-CS-A3	119	RS41	RS-CS-C2	290	RS120 , 140
RS-CS-A4	119	RF06B	RS-CS-C3	708	RS160 - 240

Note: In addition to RS Roller Chains, Chain Breakers can be used with BS Roller Chains and Marine Chains. However, Chain Breakers for Marine Chains are made-to-order.

Ordering Specify the code (product code and model)

Ordering Example

Product code	Model number	Qty	Unit
D210013	RS-CR1	1	K

4 Poly Steel Chain Cutting Tools

Standard chain cutting tools cannot be used on Poly Steel Chains. A special punch and vice for Poly Steel Chains are required.

<Cutting Tools>

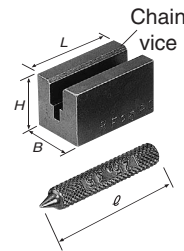

Model Number	L	H	B	phi	Applicable Chain
RS-PC01-AST	35	20	20	52	RS25-PC-1
RS-PC02-AST	50	30	30	52	RS35-PC-1
RS-PC03-AST	65	35	35	56	RS40-PC-1
RS-PC04-AST	80	40	35	56	RS50-PC-1
RS-PC05-AST	100	45	40	56	RS60-PC-1

Note: 1. The special punch and vice are included as a set.

5 Lambda Chain Cutting Tools

A special vice and a primary and secondary punch are required to disassemble Lambda Chains.

<Cutting Tools>

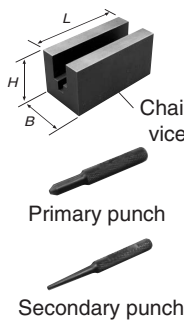

Model Number	L	H	B	Applicable Chain
RS-LMD01-AST	65	32	32	RS40-LMD-1
RS-LMD02-AST	80	40	40	RS50-LMD-1
RS-LMD03-AST	95	48	48	RS60-LMD-1
RS-LMD04-AST	130	60	60	RS80-LMD-1
RS-LMD05-AST	160	73	73	RS100-LMD-1
RS-LMD06-AST	160	88	88	RS120-LMD-1
RS-LMD07-AST	180	98	98	RS140-LMD-1

Note: 1. The special punch and vice are included as a set. Punch dimensions are the same as for the punch in section 2.

Chain Connecting Tool

1 Chain Puller

This tool pulls the two ends of the chain together when installing the chain on a machine.

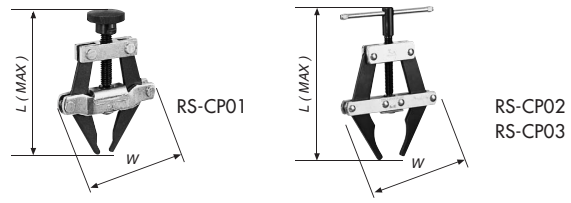

Model Number	L	W	Applicable Chain (Single-strand)
RS-CP01	118	70	RS35 - 60
RS-CP02	185	112	RS60 - 100
RS-CP03	250	145	RS80 - 240

End Fixtures

- Allows for reliable lifting equipment using RS Roller Chain.
- Designed to be stronger than RS Roller Chains, they sufficiently demonstrate RS Roller Chain's performance when connected to a chain with appropriate clearance.

■ **Ordering** : Specify the code (product code and model number)



● **Ordering Example**

Product code	Model number	Qty	Unit
D210068	RS40EB	1	K

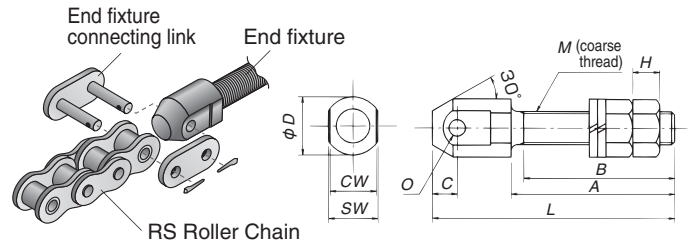

1 End Fitting Bolts (for RS Roller Chains)

Model Number	Applicable Chain	L	A	B	C	M	O	D	CW	SW	H	Approximate Weight kg/unit
RS40EB	RS40-1	61.0	41.5	38	6.0	M 8	4.00	15	11.2	13.0	6.5	0.04
RS50EB	RS50-1	72.5	48.5	44	7.5	M10	5.12	19	13.8	17.0	8.0	0.07
RS60EB	RS60-1	89.1	60.0	55	9.1	M12	5.99	21	17.8	19.0	10.0	0.12
RS80EB	RS80-1	117.1	79.0	73	12.1	M16	7.98	28	22.6	24.0	13.0	0.27
RS100EB	RS100-1	145.1	98.0	91	15.1	M20	9.58	34	27.5	30.0	16.0	0.51
RS120EB	RS120-1	173.1	117.0	108	18.1	M24	11.15	40	35.5	35.5	19.0	0.86

Note: 1. SW dimensions are designed for wrench use.
 2. Uses old JIS B1181 (type 1) nuts and JIS B1251 spring washers.
 3. Black coating.



2 End Fitting Bolt Connecting Links (for RS Roller Chains)

Model Number	Applicable Chain	P	H	D	T	L ₁	L ₂	Approximate Weight kg/unit
RS40EB-CL	RS40-1	12.70	12.0	3.97	2.0	8.8	10.2	0.01
RS50EB-CL	RS50-1	15.875	15.0	5.09	2.4	10.7	12.3	0.02
RS60EB-CL	RS60-1	19.05	18.1	5.96	3.2	14.0	16.1	0.04
RS80EB-CL	RS80-1	25.40	24.0	7.94	4.0	17.5	20.1	0.09
RS100EB-CL	RS100-1	31.75	28.6	9.54	4.8	21.0	23.7	0.156
RS120EB-CL	RS120-1	38.10	34.4	11.11	5.6	26.05	29.55	0.264

Note: 1. Contact a Tsubaki representative for connecting links and end links of differing shapes.

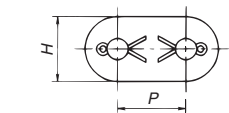
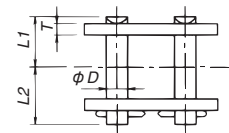

■ **Strength**

Strength when Tsubaki RS Roller Chains (except for M-type connecting links and offset links) are connected to end fitting bolts, and special connecting links are as follows.

Applicable Chain	RS40-1	RS50-1	RS60-1	RS80-1	RS100-1	RS120-1
Minimum Tensile Strength kN {kgf}	17.7{1800}	28.4{2900}	40.2{4100}	71.6{7300}	107{10900}	148{15100}
Maximum Allowable Load kN {kgf}	3.63{370}	6.37{650}	8.83{900}	14.7{1500}	22.6{2300}	30.4{3100}

⚠ **Safety Precautions**

- Operating temperature: -10 to 60°C (Contact a Tsubaki representative for use in special environments.)
- Use the Tsubaki End Fitting Bolt Connecting Link when connecting an end fitting bolt and an RS Roller Chain. We recommended disassembling and lubricating regularly for safety.
- Do not use M-type connecting links for RS Roller Chains (that have a gap between the pin and connecting link plate) or offset links.
- Use only RS Roller Chains. These end fixtures cannot be used with Lube-Free Drive Chains, Heavy Duty Roller Chains, Super-H Roller Chains, and Ultra Super Roller Chains. (When using a Super Chain, always use a Super Chain connecting link.)
- Grease the surface of the connecting link pin in advance when attaching the end fitting bolt and RS Roller Chain. Take care to attach precisely and avoid twisting the chain.
- Attach so that there is no bending load on the end fitting bolt.
- Do not subject the threads or head of the end fitting bolt to impacts or cause them to become distorted.

Automatic Lubricator for Roller Chain

■ Features

1. High safety and reliability

The lubricator, certified with the GS mark from German TÜV safety standards, is filled with grease that satisfies international FDA and NSF (formerly USDA) standards, making it safe to use in food processing. Tsubaki auto lubricators help you increase safety in HACCP systems and contribute to your product liability countermeasures.

2. Usable in explosion-proof applications

Passed screening by TIIS, a non-governmental/non-profit organization recognized by the Minister of Health, Labor, and Welfare, and is certified as an explosion-protected electrical apparatus. There is no risk of explosion or fire from sparks or high temperatures from electrical apparatuses in environments with explosive gas, proving its safety.

3. Service life adjustable

You can easily set the service life to between 1 – 12 months with just an Allen wrench. Once set, the unit automatically operates by means of a gas generator.

4. Reduced maintenance time, features an inspection window

Automatic lubrication eliminates the need for frequent manual lubrication, which simplifies your lubrication schedule. The transparent PET plastic lubricator also features an inspection window so you can always check remaining lube and operating condition.

5. Lightweight, compact

Compact, with a diameter of $\phi 50$ and a height of 114mm (125mL), and weighing only 190g.

6. Can be installed in any direction

The lubricator can be installed facing up, down, or horizontally. However, if a brush is used it must be installed facing down.

7. Dust and water proof

Certified IP68 as dust and water proof for use in dusty or watery environments.

Body
Model no.: SFM68

Clamp (optional)
Model no.: SFM-ST2010

Brush (optional)
Model no.: SFM-ST2034



■ Ordering Please specify the code (product code and model number)

● Ordering Example

Product Code	Model No.	Qty	Unit (pc)
D210062	SFM68	1	K

■ Code chart

Product Code	Model Number
D210062	SFM68
D210063	SFM-ST2034
D210064	SFM-ST2010

■ Specifications

Operation	Hs gas pressure (dry battery type)
Operational pressure	Max. 0.3MPa
Volume	125ml
Discharge period	1 – 12 months, non-incremental (at an ambient temperature of 20°C)
Operating temperature range	-20 to 55°C
Oil	Food grade oil (H1)

■ Dimensions

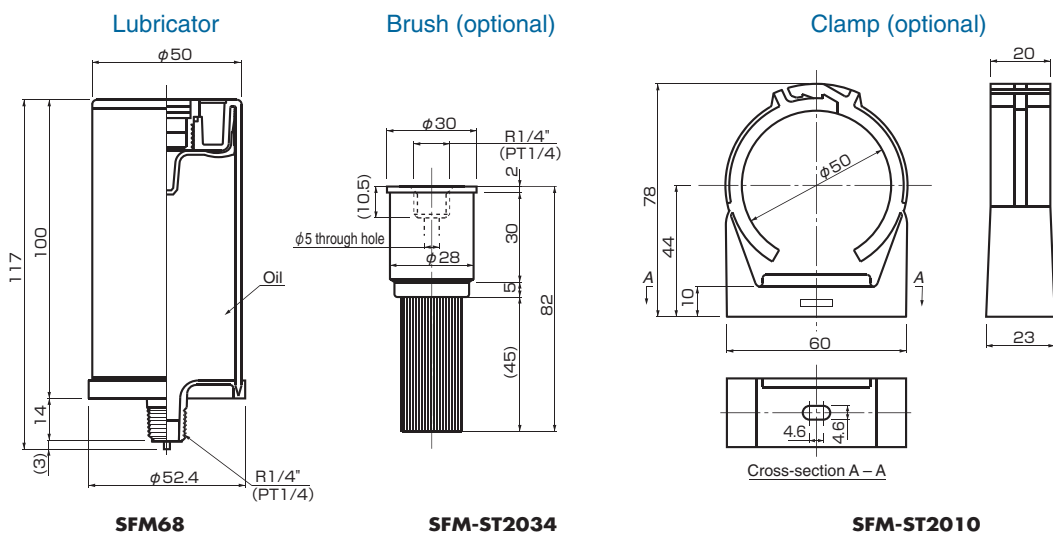

Automatic Lubricator for Roller Chain

Operating principle

Turning on the gas generator switch generates H₂ gas, the pressure of which pushes down on a piston and releases oil from the bottom of the lubricator. Setting the time adjustment dial allows users to control the amount of H₂ gas generated for 1 – 12 months, thereby adjusting oil flow in one single step.

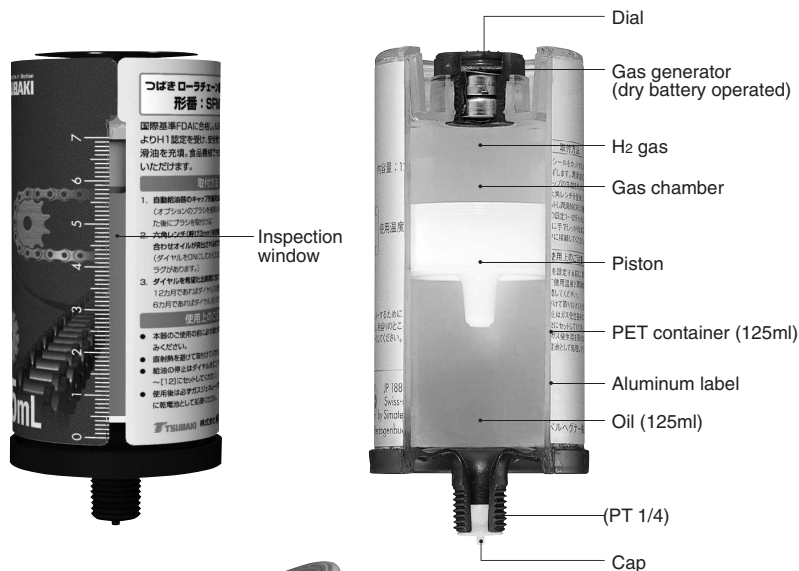

Installation

Position the lubricator with the optional brush attached on the chain sag side so that oil can penetrate between the outer and inner plates. This will ensure the area between bushes and rollers are lubricated as well. The lubricator brush should lightly touch the chain plates. (See diagram on right.) Secure the optional clamp by drilling a tap hole in a bar or the like and securing with an M4 bolt, or by drilling a hole that an M4 bolt can pass through and securing with a nut. (See diagram on bottom right.)

Caution: The automatic lubricator should be used with roller chains operating in the "brush lubrication" or "drip lubrication" range. This product will not provide enough lubrication for roller chains used in the "oil bath" or "forced lubrication" range and should not be used.

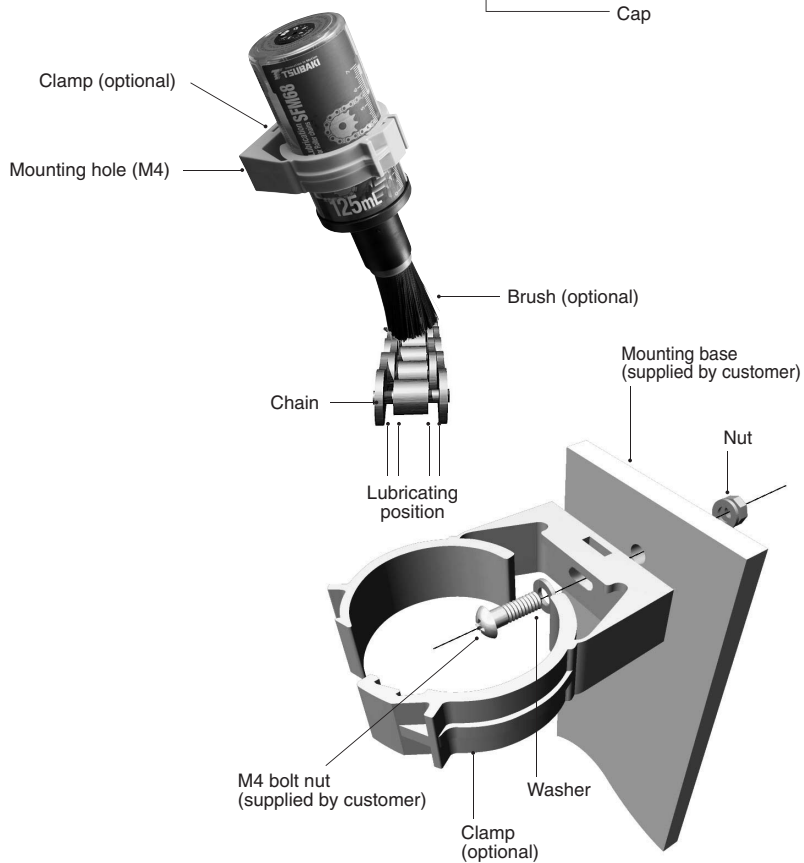

[Recommended Usage Range]

- Chain sizes
#40 - #100 class drive chains and small size conveyor chains
- Chain speed
Less than 50m/min
- Current lubrication method
Brush or drip lubrication

Notes on Usage

- The amount of oil dispensed varies with ambient temperature. Especially, the amount of oil released will be lower in lower temperatures, so the dial should be set to a lower value (shorter than your desired discharge time). (See diagram on right.)
- The length of the lubrication path (piping) should be less than 0.5m, with an inner diameter greater than 6mm. The path should also not be segmented.
- CAUTION: Do not use where exposed to flame or direct sunlight.
- Do not use where oil may contact or mix with food.
- When stopping oil discharge midway, be sure to set the dial to zero "0."

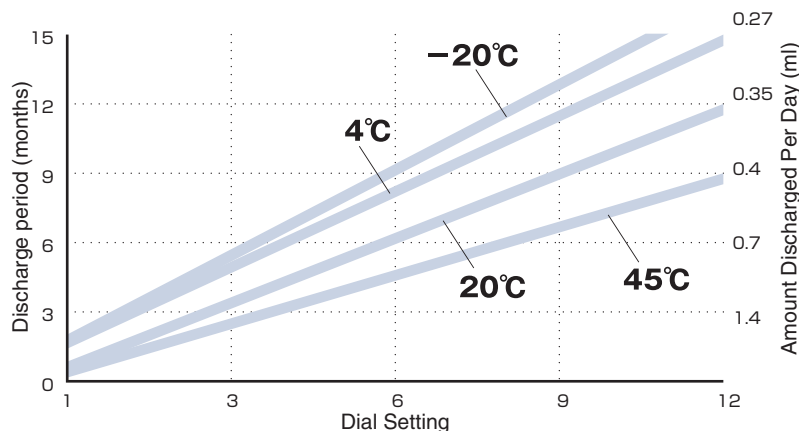

Chain Elongation Scale

The chain elongation scale allows for quick checks of a chain's pitch elongation limit.

Used to check chain elongation on RS Roller Chains, BS Roller Chains, and Leaf Chains to determine when it is time for the chain to be replaced.

■ **Ordering** : Specify the code (product code and model number)

● **Ordering Example**

Product code	Model number	Qty	Unit
D210067	RS-CES	1	C

Note: 10 items per case

■ **Applicable chain sizes**

- RS Roller Chains : RS40 to RS240
- BS Roller Chains : RS08B to RS32B
- Leaf Chains (AL/BL) : #400 to #1600

■ **Measurement procedure**

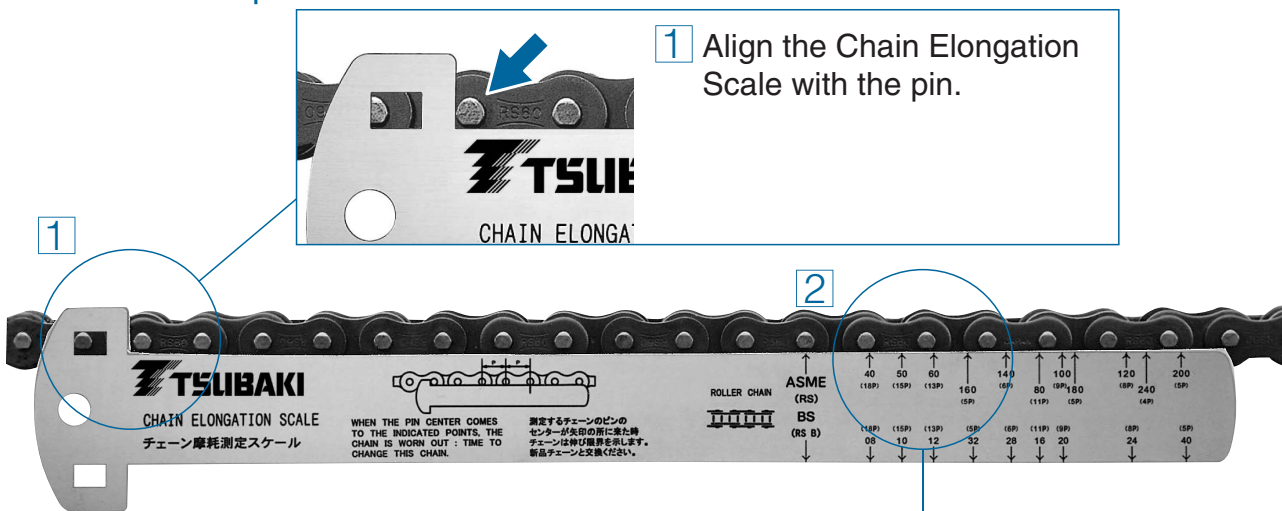

2 Check where along the scale the pin is positioned (pitch indicated in parentheses).

Scale positioning on a new product

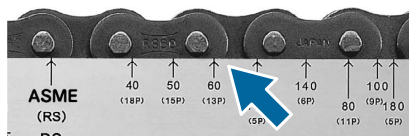

Wear elongation limit

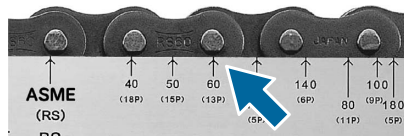

If the point or the scale is past the center of the pin, the chain has reached its elongation limit and should be replaced.

⚠ **Safety Precautions**

- Depending on the attachment and chain size, there may be interference with the Elongation Scale for specialty attachment chains or K2 attachment chains (catalog item).
- Check chain elongation at the location on the chain where the sprocket teeth engage the most.
- Check chain elongation at a location on the chain where tensile force is applied.
- Do not use the scale for any purpose other than measuring chain elongation.
- Always turn off the power switch to the equipment and confirm that it has come to a complete stop before checking chain elongation. In addition, make sure that the switch cannot be turned on accidentally.

Roller Chain / Sprocket Selection, Installation, and Maintenance

$$L = \frac{Z + Z'}{2} + 2C + \frac{\left(\frac{Z - Z'}{6.28}\right)^2}{C} \quad V = \frac{P \times Z' \times n}{1000} \text{ (m/min)}$$

$$F_m = \frac{60 \times kW}{V} \text{ (kN)}$$

$$L = \frac{180^\circ}{\tan^{-1}\left(\frac{P}{D + 2S}\right)} \quad I_r = M \times \left(\frac{V}{2\pi n}\right)^2 \text{ (kg} \cdot \text{m}^2)$$

$$T_n = 9.55 \times \frac{kW}{n_1} \text{ (kN} \cdot \text{m)}$$

$$T_r = \frac{M \times d}{2 \times 1000 \times i} \times \frac{G}{1000} \text{ (kN} \cdot \text{m)}$$

$$T_r = F'c \times \frac{1}{2 \times 1000 \times i} \text{ (kN} \cdot \text{m)}$$

$$T_m = \frac{T_s(\%) + T_b(\%)}{2 \times 100} \times T_n \text{ (kN} \cdot \text{m)}$$

$$\text{または } T_m = \frac{T_s \text{ (kN} \cdot \text{m)} + T_b \text{ (kN} \cdot \text{m)}}{2} \text{ (kN} \cdot \text{m)}$$

$$F_{ms} = \frac{T_s(\%) \times i}{d \cdot (2 \times 1000) \times 100} \times T_n \times 1 \text{ (kN)}$$

$$\text{または } F_{ms} = \frac{T_s \text{ (kN} \cdot \text{m)} \times i}{d \cdot (2 \times 1000)} \times 1 \text{ (kN)}$$

$$F_{mb} = \frac{T_b(\%) \times i}{d \cdot (2 \times 1000) \times 100} \times T_n \times 1.2 \text{ (kN)}$$

$$\text{または } F_{mb} = \frac{T_b \text{ (kN} \cdot \text{m)} \times i}{d \cdot (2 \times 1000)} \times 1.2 \text{ (kN)}$$

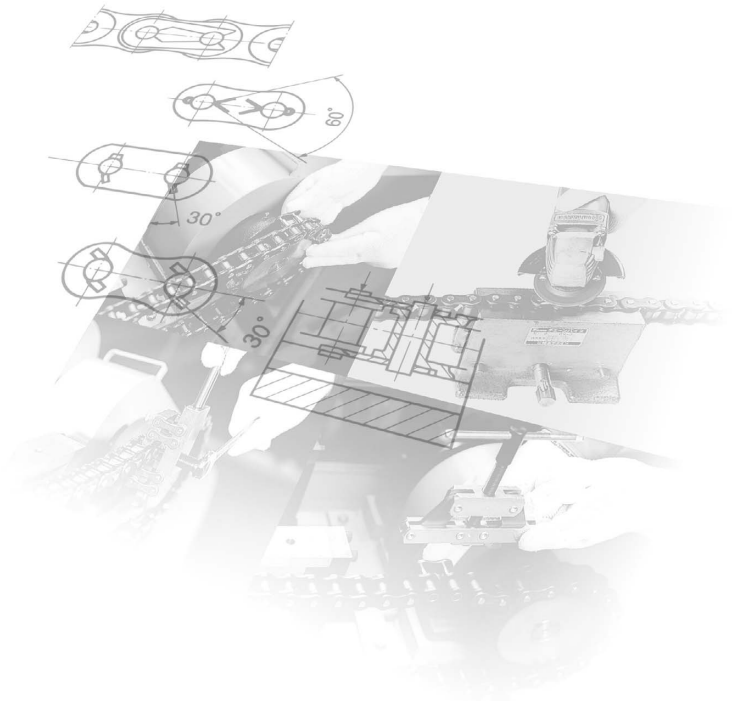

1. Selection Guide Pg. 163
2. Service Factors Pg. 165
3. Provisional Selection Chart .. Pg. 166
4. Selection Formulae Pg. 168
5. General Selection Pg. 171
6. Allowable Load Selection... Pg. 173
7. Example of Lifting Transmissions .. Pg. 178
8. Calculating Moment of Inertia .. Pg. 180
9. Example of Shuttle Traction .. Pg. 181
10. Pin Gear Drive Selection ... Pg. 182
11. Temperature Selection Pg. 188
12. Special Selection Method for Corrosion Resistant Roller Chain .. Pg. 188
13. Corrosion Resistance Guide for Drive Chains and Sprockets .. Pg. 189

1. How to Cut Roller Chain ... Pg. 190
2. How to Connect Roller Chain... Pg. 191
3. Roller Chain Lubrication... Pg. 192
4. Layout and Installation Pg. 194
5. Sprockets Pg. 196
6. Chain Test Run Pg. 197
7. Roller Chain Inspection..... Pg. 197
8. Cautions on Use in Special Environments .. Pg. 201
9. Troubleshooting Pg. 202

Roller Chain Selection

1. Selection Guide

Application — Key points for selection — **Selection method**

Ordinary transmission — Selection using kilowatt ratings tables — **General selection method**

Page 171

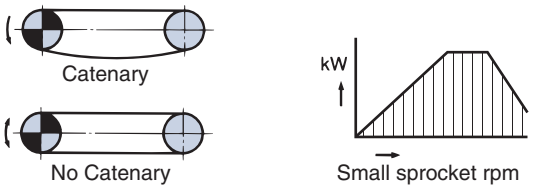

Ordinary transmission — Selection based on maximum allowable load — **Allowable load selection method**

Starting frequency 5 times/day (8 hrs) or less
Page 173

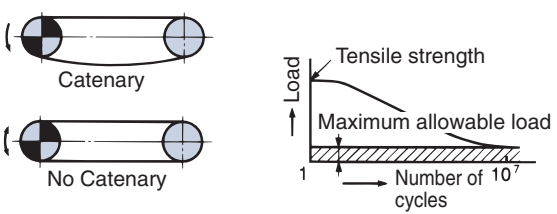

Lifting applications — Selection based on maximum allowable load — **Example of lifting transmissions**

Page 178

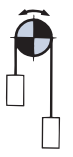

For connecting links, use F-type connecting links or connecting links for end fixtures. (Pg. 158, for RS chains only.)

Shuttle traction — Selection based on maximum allowable load — **Example of shuttle traction**

Page 181

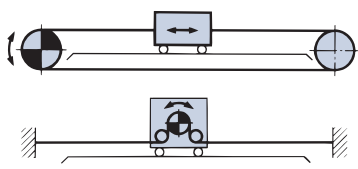

Pin gear drive — Selection based on maximum allowable load (Chain speed $V = 50$ m/min or less) — **Pin gear drive selection**

Page 182

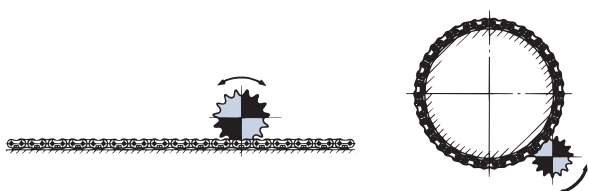

Chain Type	Connecting parts that can be used in a normal atmosphere from -10°C to 60°C.			
	M type CL	F type CL	2-pitch OL	1-pitch OL
RS	○	○	○	□
BS/DIN	○	○	□	□
RS-LMD	○	○	—	□
RS-LMD-NP	○	—	—	□
RS-LMDX	○	—	—	—
BS-LMD	○	—	—	□
RS-SUP	○	○	—	—
RS-HT-F	—	○	—	—
RS-SNS	○	○	○	□
RS	○	○	○	△
BS/DIN	○	○	△	△
RS-SUP	○	○	—	—
RS-HT-F	—	○	—	—
RS-SUP-H	—	○	—	—
RF-US	—	○	—	—
NP	○	○	—	△
NEP	○	○	—	—
SS, AS	○	—	—	○
RS-PC	○	—	—	—
RS-PC-SY	○	—	—	—
NS	○	—	—	○
TI	○	—	—	○
KT	△	○	—	△
RS-CU	○	○	—	—
RS-CU-SS	○	—	—	—
RS Attachment	○	—	—	—
RS	○	○	×	×
RS-SUP	○	○	—	—

Remark: RS-SUP is only available in 4-pitch OL.

CL: "Connecting link" OL: "Offset link"

○ : Usable □ : Allow for a reduction in kilowatt ratings
 △ : Allow for a reduction in strength — : Manufacturing not possible × : Unusable Dotted line: Made-to-order product

Before Use Standard Roller Chains Lubrication Lubrication-Free Roller Chains Heavy Duty Roller Chains Corrosion Resistant Roller Chains Specialty Roller Chains Sprockets Pin Gear Drives Accessories Selection Handling

Other selections

Roller drive

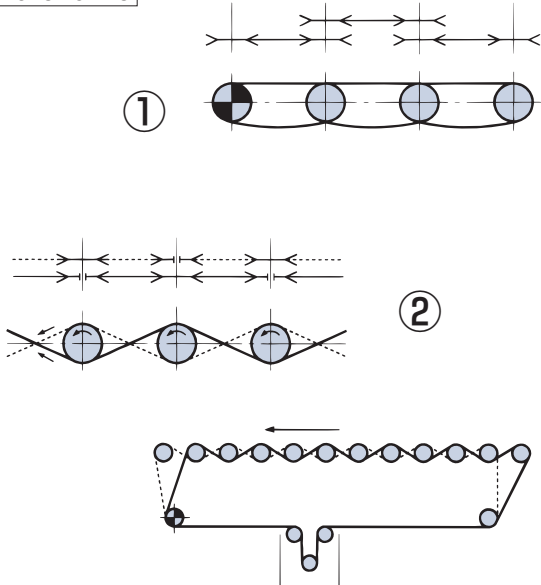

Multi-shaft drive

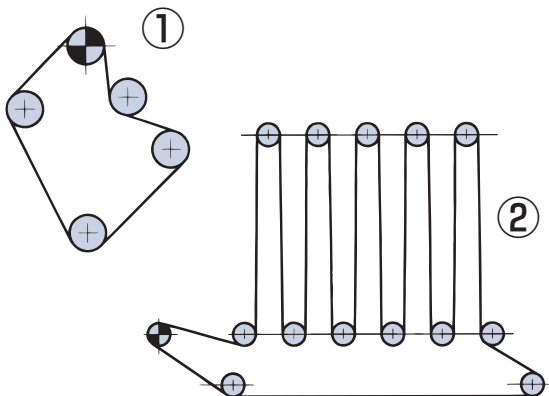

High-speed drive

Right side from peak of kW ratings tables (shaded area)

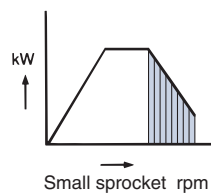

Vertical shaft drive

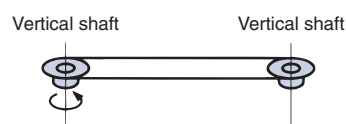

Required information for roller chain selection

- 1) Machine used
- 2) Type of impact
- 3) Motor type
- 4) Rated power of motor
- 5) Bore diameter of high-speed shaft and RPM
- 6) Bore diameter of low-speed shaft and RPM
- 7) Distance between shafts

Motor characteristics required for chain selection

When using the allowable load selection method or the pin gear drive selection method, check the following characteristics of the motor.

- 1) Moment of inertia of motor
- 2) Rated torque of motor, or output shaft RPM
- 3) Starting torque of motor
- 4) Stalling torque of motor

⚠ Safety precautions

The roller chain selection conditions provided here are only applicable to the selection of roller chain model and size. Please evaluate accessory devices such as safety and lubrication devices separately.

Please contact a Tsubaki representative regarding these applications.

Roller Chain Selection

2. Service Factors

Multi-strand factor

The load borne by multi-strand roller chain is unequal across the width of the chain, and thus it cannot be expected that the transmission capacity will be equal to the capacity of a single-strand roller chain multiplied by the number of strands. For this reason, the transmission capacity of multi-strand roller chain is obtained by multiplying the transmission capacity of single-strand roller chain by a multi-strand factor.

Table 1: Multi-strand factor

Number of roller chain strands	Multi-strand factor
Double strand	1.7
Triple strand	2.5
Quadruple strand	3.3
Quintuple strand	3.9
Sextuple strand	4.6

Service factor Ks

The kW ratings are based on conditions of minimal load fluctuation. Depending on the degree of load fluctuation, it may be necessary to correct the kilowatt ratings using the service factor Ks. Use Table 2 below to determine the appropriate service factor based on the type of machine and the source of power. The design kW value is obtained by multiplying the kilowatt ratings by the service factor.

Table 2: Service factor Ks

Type of impact	Power source Example machines	Motor or Turbine	Internal combustion engine	
			With hydraulic drive	Without hydraulic drive
Smooth	Belt conveyors with little load fluctuation, chain conveyors, centrifugal pumps, centrifugal blowers, ordinary textile machines, and ordinary machines with little load fluctuation.	1.0	1.0	1.2
Moderate	Centrifugal compressors, marine engines, conveyors with moderate load fluctuation, automatic furnaces, dryers, pulverizers, general machine tools, compressors, general construction machines, general paper mill machines.	1.3	1.2	1.4
Large	Presses, crushers, construction and mining equipment, vibration machines, oil well rigs, rubber mixers, rolls, roll gangs, general machines with reverse or large-impact loads.	1.5	1.4	1.7

RPM factor Kn and teeth factor Kz

Table 3: RPM factor Kn and number of teeth factor Kz

RPM r/min	RPM factor Kn	Number of teeth	Teeth factor Kz
Less than 27	1.00	9 or more, less than 12	1.16
27 or more, less than 37	1.03	12 or more, less than 15	1.14
37 or more, less than 50	1.07	15 or more, less than 18	1.12
50 or more, less than 70	1.10	18 or more, less than 24	1.10
70 or more, less than 100	1.14	24 or more, less than 30	1.08
100 or more, less than 150	1.19	30 or more, less than 38	1.06
150 or more, less than 300	1.27	38 or more, less than 47	1.04
300 or more, less than 500	1.34	47 or more, less than 60	1.02
500 or more, less than 1000	1.44	60 or higher	1.00
1000 or more, less than 2000	1.54		
2000 or more, less than 4000	1.65		

Shock factor K

This coefficient is determined by the ratio of the moments of inertia between the prime mover and the driven machine (rate of I, GD^2), and the amount of backlash in the transmission device.

When the inertia ratio R is greater than 10, use R = 10. When the inertia ratio R is less than 0.2, use R = 0.2.

If I or GD^2 of the prime mover or driven machine is unknown, use the value of R in Figure 1.

Figure 1: Shock factor K

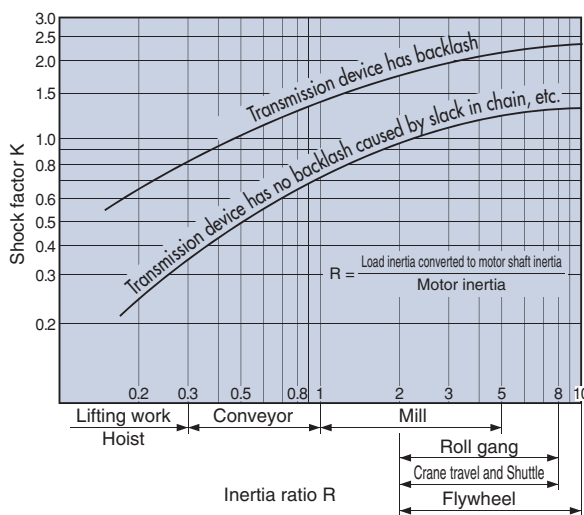

Imbalance load factor Ku

When carrying out shuttle traction and lifting with two chains, or four chains for shuttle drive and lifting, the chain tension will not be uniform. This must be accounted for by multiplying the following imbalance load coefficient K_u to adjust the left-and-right load imbalance. Example: For four lifting strands, the imbalance load factor for one strand $K_u = 0.6 \times 0.6 = 0.36$

Table 4: Imbalance load factor Ku

2 lifting strands	0.6
4 lifting strands	0.36

3. Provisional Selection Graph

Figure 2: RS Standard Roller Chain Provisional Selection Graph

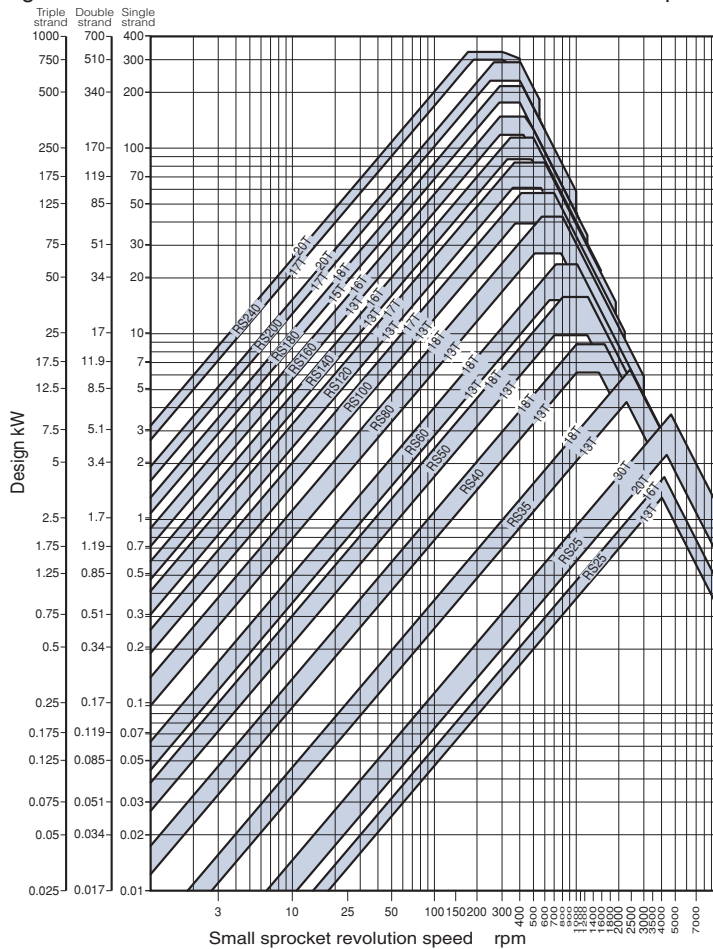

■ How to use this table (Fig. 2)

1. Example: Single-strand chain, design kW=7kW

- (1) Assume that the speed of the small sprocket is 100 rpm. Judging from the intersecting point of design kW value of 7 kW (vertical axis) and the speed value of 100 rpm (horizontal axis), RS80 and a sprocket with between 13 and 18 teeth would be appropriate. Therefore, based on the position of the intersection, we can see that a 15T sprocket can be used.
- (2) Assume that the speed of the small sprocket is 200 rpm. Following the same procedure shown in the above example, RS80 and a sprocket with less than 13 teeth or RS60 and a sprocket with more than 18 teeth would be appropriate. This table is used for tentative selections only. The kW ratings tables should be used to confirm the chain sizes.
- (3) Please allow for a drop in the kW rating values shown in the design kW ratings chart (Fig.2) when 1-pitch offset links or Super 4POL are used.

Figure 3: RS-HT Roller Chain Provisional Selection Graph

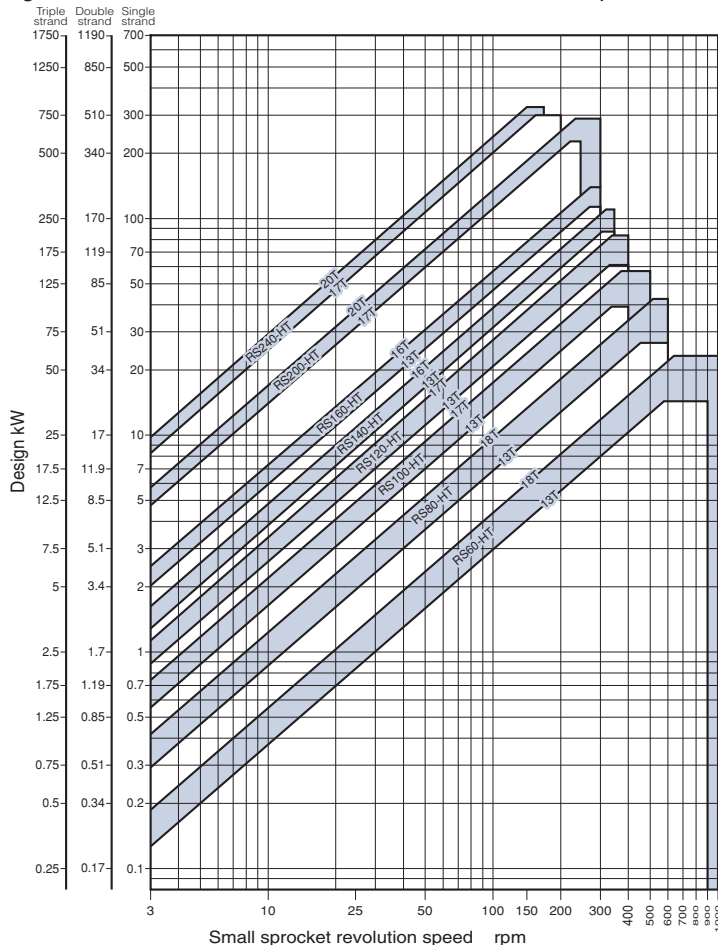

Roller Chain Selection

Figure 4: RS Super Roller Chain Provisional Selection Graph

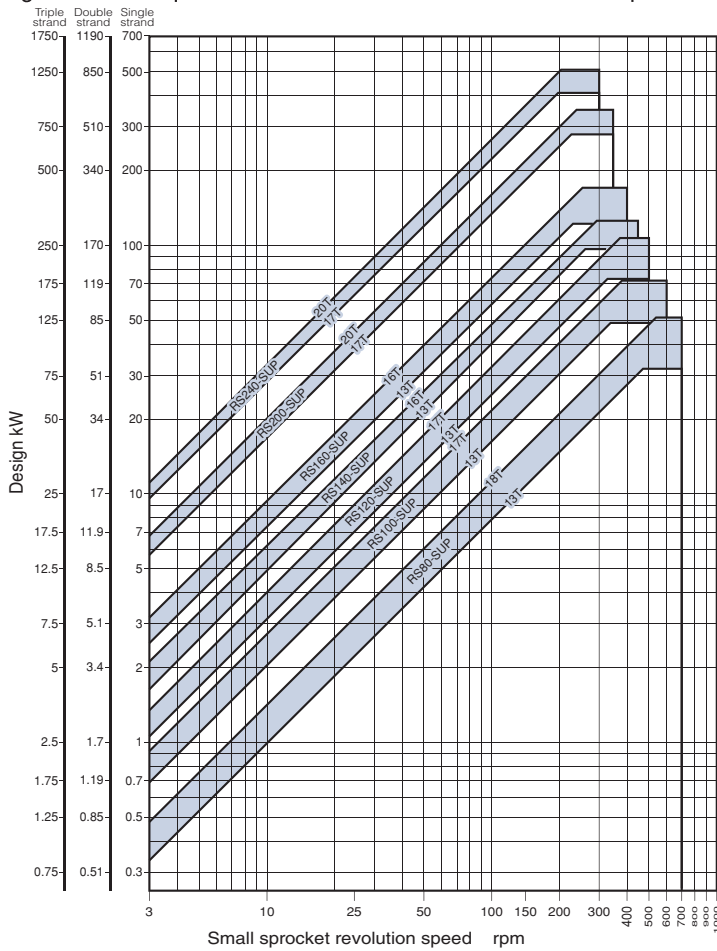
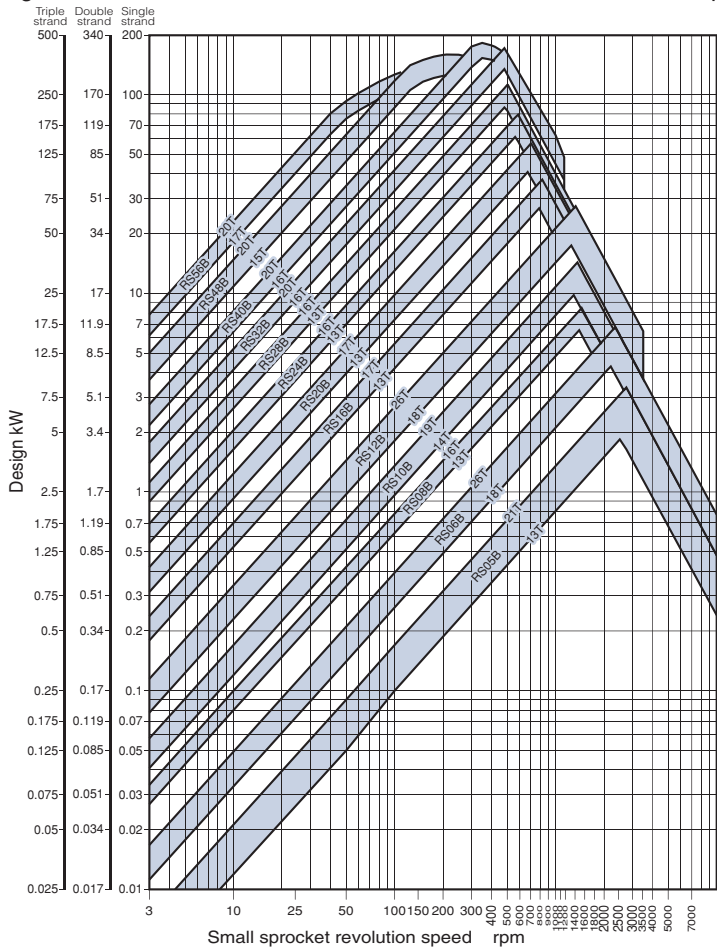

Figure 5: BS/DIN Standard Roller Chain Provisional Selection Graph



Before Use
 Standard Roller Chains
 Lube-Free Roller Chains
 Heavy Duty Roller Chains
 Corrosion Resistant Roller Chains
 Specialty Roller Chains
 Sprockets
 Pin Gear Drives
 Accessories
 Selection
 Handling

4. Selection Formulae

SI units and gravimetric units are both indicated

4-1 Symbols and units used in formulae (Table 5)

Symbol	Description	SI units	Gravimetric units
C	Center distance in pitches	—	—
C'	Center distance between shafts	m	m
d	Pitch circle diameter of the small sprocket	mm	mm
d ₂	Pitch circle diameter of the large sprocket	mm	mm
D	Outer diameter of the drum	mm	mm
F _b	Chain tension when the prime mover is decelerating (stalling)	kN	kgf
F' _b	Design chain tension when the prime mover is decelerating (stalling)	kN	kgf
F _c	Chain tension of shuttle drive	kN	kgf
F' _c	Design chain tension of shuttle drive	kN	kgf
F _ℓ	Chain tension from torque on load side (actual load)	kN	kgf
F' _ℓ	Design chain tension from torque on load side (actual load)	kN	kgf
F _m	Chain tension from prime mover rated output	kN	kgf
F' _m	Design chain tension from prime mover rated output	kN	kgf
F _{ms}	Chain tension from starting torque of prime mover	kN	kgf
F' _{ms}	Design chain tension from starting torque of prime mover	kN	kgf
F _{mb}	Chain tension from stalling torque of prime mover	kN	kgf
F' _{mb}	Design chain tension from stalling torque of prime mover	kN	kgf
F _s	Chain tension when prime mover accelerates (starting)	kN	kgf
F' _s	Design chain tension when prime mover accelerates (starting)	kN	kgf
F _w	Chain tension from load (actual load)	kN	kgf
F' _w	Design chain tension from load (actual load)	kN	kgf
f _i	Coefficient of friction between roller and rail (with lubrication 0.14, without lubrication 0.21)	—	—
G	Standard acceleration from gravity $G = 9.80665 \text{ m/s}^2$	—	—
i	Speed ratio (example) if ratio is 1/30 than $i = 30$	—	—
I _ℓ {GD ² ℓ}	Converted moment of inertia of the loaded prime mover output shaft	kg·m ²	kgf·m ²
I _m {GD ² m}	Moment of inertia of the prime mover output shaft	kg·m ²	kgf·m ²
K	Shock factor	Refer Table 4	—
K _n	RPM factor	—	—
K _s	Service factor	Refer Table 2	—
K _u	Imbalance load factor	Refer Table 5	—
K _v	Speed factor	Refer Table 3	—
K _z	Number of teeth factor	—	—
L	Chain length (number of links)	—	—
m	Unit mass of chain	kg/m	kgf/m
M{W}	Mass of load (weight)	kg	kgf
μ	Coefficient of friction between the rail and the axle = 0.1 (shuttle drive) Coefficient of friction between the rotating body and the support rollers = 0.3 (pin gear)	—	—
n	RPM of the small sprocket	rpm	rpm
n ₁	RPM of driver shaft	rpm	rpm
n ₂	RPM of driven shaft	rpm	rpm
P	Chain pitch	mm	mm
R	Inertia ratio	Refer Table 4	—
S	Attachment height for RS attachment chain (distance from the drum surface to the chain pitch center)	mm	mm
t _b	The time for deceleration of the prime mover (when stalling)	s	s
t _s	The time for acceleration of the prime mover (when starting)	s	s
T _b	Stalling torque of the prime mover	% (kN·m)	% (kgf·m)
T _s	Starting torque of the prime mover	% (kN·m)	% (kgf·m)
T _ℓ	Load torque	kN·m	kgf·m
T _m	Working torque	kN·m	kgf·m
T _n	Rated torque of the prime mover	kN·m	kgf·m
V	Chain speed	m/min	m/min
Z	Number of teeth of large sprocket	—	—
Z'	Number of teeth of small sprocket	—	—

Roller Chain Selection

4-2 Formulae (Table 6)

- 1) Perform all selections using a transmission efficiency, including the chain, of $\eta = 1$.
- 2) Use the values calculated in items 11 and 12 of this table for the tension and kW ratings used for selection.

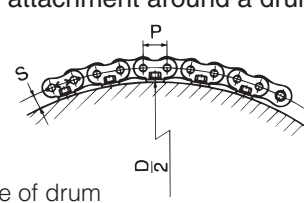
Item	SI units	Gravitational units
1. Chain length (number of links): L Ordinary transmission	<p>Ordinary transmission between two shafts</p> <p>(1) When the number of teeth and distance between shafts has been decided for both sprockets:</p> $L = \frac{Z + Z'}{2} + 2C + \frac{\left(\frac{Z - Z'}{6.28}\right)^2}{C}$ <p>(2) When the number of links of chain and the number of teeth has been decided:</p> $C = \frac{1}{8} \left\{ 2L - Z - Z' + \sqrt{(2L - Z - Z')^2 - \frac{8}{9.86}(Z - Z')^2} \right\}$ <p>Even if the fractional part of the value found for L (below that of the decimal point) is small, round it up to the nearest integer and add a link. An offset link must be used when an odd number of links exist. However, if possible, change the number of teeth on the sprocket or the distance between shafts so that an even number of links may be used.</p>	
Pin gear drive	<p>When using a chain with attachment around a drum</p> $L = \frac{180^\circ}{\tan^{-1}\left(\frac{P}{D + 2S}\right)}$ <p>P: Chain pitch D: Outer circumference of drum S: Height of attachment</p> 	<p>Round L up to an even number of links. When attaching the chain attachment around the drum, insert shims at equal intervals for adjustment.</p>
2. Chain speed: V	$V = \frac{P \times Z' \times n}{1000}$ (m/min)	
3. Chain tension from rated output (kW) of motor: Fm	$F_m = \frac{60 \times \text{kW}}{V}$ (kN)	$F_m = \frac{6120 \times \text{kW}}{V}$ (kgf)
4. Inertia where the motor shaft converts the moment of inertia of the load I (GD ²): I _ℓ (GD ² _ℓ)	$I_\ell = M \times \left(\frac{V}{2\pi n_1}\right)^2$ (kg·m ²)	$GD_\ell^2 = W \times \left(\frac{V}{\pi n_1}\right)^2$ (kgf·m ²)
5. Rated torque of motor: Tn	$T_n = 9.55 \times \frac{\text{kW}}{n_1}$ (kN·m)	$T_n = 974 \times \frac{\text{kW}}{n_1}$ (kgf·m)
6. Working torque: Tm	$T_m = \frac{T_s(\%) + T_b(\%)}{2 \times 100} \times T_n$ (kN·m) Or $T_m = \frac{T_s(\text{kN}\cdot\text{m}) + T_b(\text{kN}\cdot\text{m})}{2}$ (kN·m)	$T_m = \frac{T_s(\%) + T_b(\%)}{2 \times 100} \times T_n$ (kgf·m) Or $T_m = \frac{T_s(\text{kgf}\cdot\text{m}) + T_b(\text{kgf}\cdot\text{m})}{2}$ (kgf·m)
7. Chain tension from starting torque: Fms Chain tension from stalling torque: Fmb	$F_{ms} = \frac{T_s(\%) \times i}{\{d/(2 \times 1000)\} \times 100} \times T_n \times 1$ (kN) Or $F_{ms} = \frac{T_s(\text{kN}\cdot\text{m}) \times i}{d/(2 \times 1000)} \times 1$ (kN) $F_{mb} = \frac{T_b(\%) \times i}{\{d/(2 \times 1000)\} \times 100} \times T_n \times 1.2^*$ (kN) Or $F_{mb} = \frac{T_b(\text{kN}\cdot\text{m}) \times i}{d/(2 \times 1000)} \times 1.2^*$ (kN)	$F_{ms} = \frac{T_s(\%) \times i}{\{d/(2 \times 1000)\} \times 100} \times T_n \times 1$ (kgf·m) Or $F_{ms} = \frac{T_s(\text{kgf}\cdot\text{m}) \times i}{d/(2 \times 1000)} \times 1$ (kgf·m) $F_{mb} = \frac{T_b(\%) \times i}{\{d/(2 \times 1000)\} \times 100} \times T_n \times 1.2^*$ (kgf·m) Or $F_{mb} = \frac{T_b(\text{kgf}\cdot\text{m}) \times i}{d/(2 \times 1000)} \times 1.2^*$ (kgf·m)

Before Use
 Standard Roller Chains
 Lubrication-Free Roller Chains
 Heavy Duty Roller Chains
 Corrosion Resistant Roller Chains
 Specialty Roller Chains
 Sprockets
 Pin Gear Drives
 Accessories
 Selection
 Handling

Item	SI units	Gravimetric units
8. Chain tension when motor accelerates: F_s Chain tension when motor decelerates: F_b	$F_s = \frac{M \times V}{t_s \times 60 \times 1000} + F_w \quad (\text{kN})$ $F_b = \frac{M \times V}{t_b \times 60 \times 1000} + F_w^* \quad (\text{kN})$	$F_s = \frac{W \times V}{t_s \times 60 \times \underline{G}} + F_w \quad (\text{kgf})$ $F_b = \frac{W \times V}{t_b \times 60 \times \underline{G}} + F_w \quad (\text{kgf})$
9. Design kW (for general selection)	Design kW = Rated kW of motor x K_s (kW)	
10. Design chain tension Design chain tension from motor: $F'm$ Design chain tension from starting torque: $F'm_s$ Design chain tension from stalling torque: $F'm_b$ Design chain tension from shuttle drive: $F'c$ Design chain tension during acceleration: $F's$ Design chain tension during deceleration: $F'b$ Design chain tension from load: $F'w$	$F'm = F_m \times K_s \times K_n \times K_z \quad (\text{kN} \{ \text{kgf} \})$ $F'm_s = F_{m_s} \times K \times K_n \times K_z \quad (\text{kN} \{ \text{kgf} \})$ $F'm_b = F_{m_b} \times K \times K_n \times K_z \quad (\text{kN} \{ \text{kgf} \})$ $F'c = F_c \times K_s \times K_n \times K_z \quad (\text{kN} \{ \text{kgf} \})$ $F's = F_s \times K_n \times K_z \quad (\text{kN} \{ \text{kgf} \})$ $F'b = F_b \times K_n \times K_z \quad (\text{kN} \{ \text{kgf} \})$	$F'w = W \text{ (Or } F_w) \times K_s \times K_n \times K_z \quad (\text{kgf})$
	$F'w = M \times K_s \times K_n \times K_z \times \frac{\underline{G}}{1000} \quad (\text{kN})$	
	If the mass M (weight W) is not known, use the rated torque T_n of the motor to calculate the shaft torque $T = T_n \times i$ kN·m {kgf·m}, and use $F = 2T/d$ in place of W .	
11. Acceleration time of motor: t_s	$t_s = \frac{(I_m + I_\ell) \times n_1}{9550 \times (T_m - T_\ell)} \times (\text{s})$	$t_s = \frac{(GD_m^2 + GD_\ell^2) \times n_1}{375 \times (T_m - T_\ell)} \quad (\text{s})$
12. Deceleration time of motor: t_b	$t_b = \frac{(I_m + I_\ell) \times n_1}{9550 \times (T_m + T_\ell)} \times (\text{s})$	$t_b = \frac{(GD_m^2 + GD_\ell^2) \times n_1}{375 \times (T_m + T_\ell)} \quad (\text{s})$
13. Inertia ratio: R	$R = \frac{I_\ell}{I_m}$	$R = \frac{GD_\ell^2}{GD_m^2}$
14. Conversion of the flywheel effect (GD^2) to moment of inertia (I)	$1 \text{ kg} \cdot \text{m}^2 \cdots (I)$	$4 \text{ kgf} \cdot \text{m}^2 \cdots (GD^2)$

All chain tensions in the above formulae are the tensions when one strand of chain is used. When using two or more strands of chain, calculate the chain tension for one strand and multiply it by the imbalance load factor K_u (Table 4) for the number of strands used.

Roller Chain Selection

5. General Selection Method

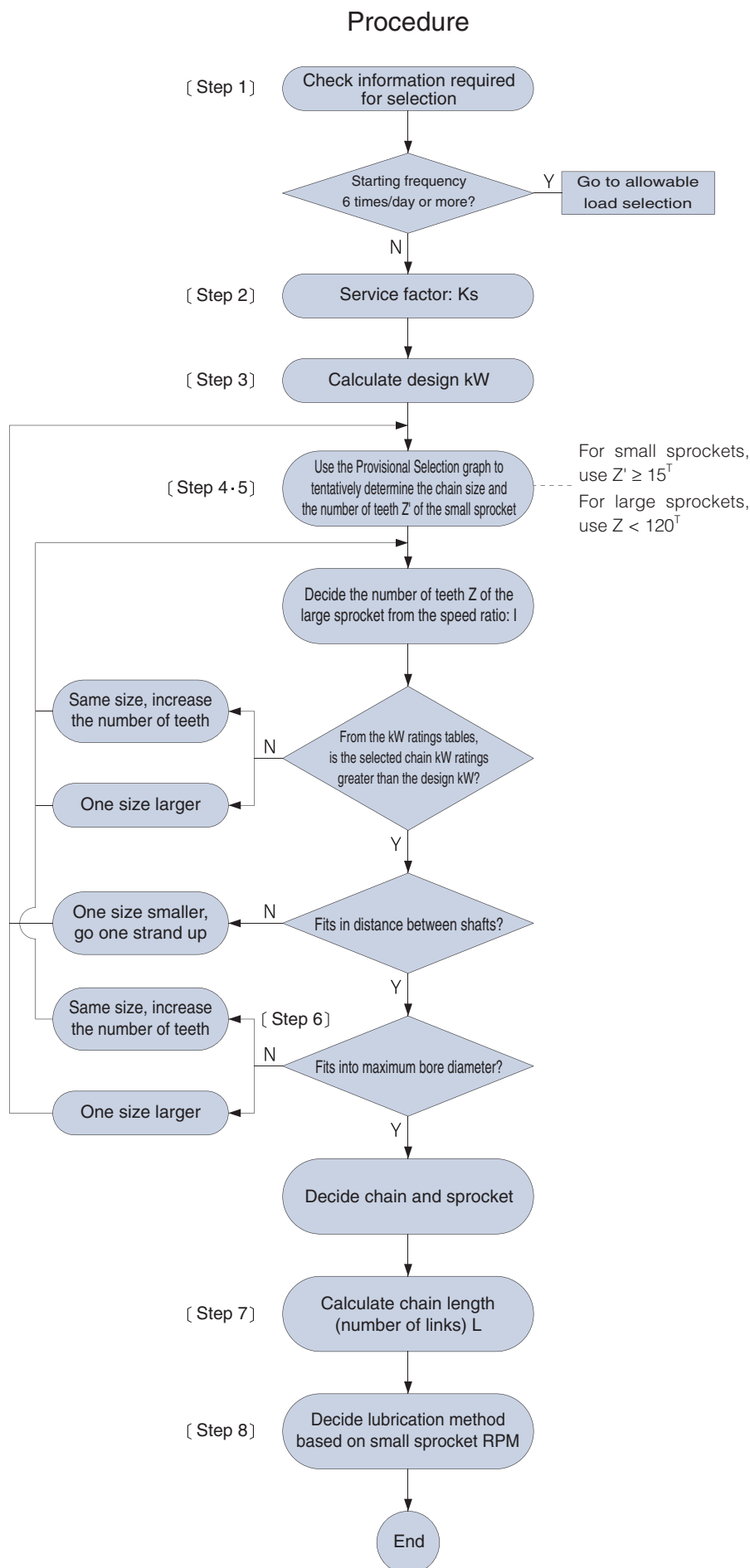

Ordinary transmission (forward / reverse), continual revolution transmission
Using kW ratings tables, infrequent start-up

Steps 4 and 5

(1) Select chain and number of teeth of small sprocket

Use the provisional selection graph (Fig. 2, 3 and 4) or the kW ratings tables to obtain a chain and small sprocket number of teeth that satisfy the revolution speed of the high-speed shaft and the transmission kW. Select a chain with the smallest pitch that has the required kW ratings.

If a single strand chain does not have sufficient power, select a multi-strand chain. If site restrictions require a short distance between shafts and the smallest possible sprocket outer diameter, use a multi-strand roller chain with a small pitch.

(2) Select number of teeth for large sprocket

Once the number of teeth of the small sprocket has been decided, the number of teeth of the large sprocket is determined by multiplying the number of teeth of the small sprocket by the speed ratio.

The number of teeth of the small sprocket should be at least 15. However, it is not desirable if this causes the number of teeth of the large sprocket to exceed 120. In this event, the number of teeth of the small sprocket must be reduced; however, it is recommended to use more than 13 teeth.

Step 7

When the number of links is odd

If the number of links is odd, it is best to avoid using an offset link and instead change the distance between shafts so that the number of links is even. If the one-pitch offset link of RS roller chain or the four-pitch offset link of Super chain is used, allow for a decrease of transmission power as explained in the notes in the kW ratings tables.

Selection example using the general selection method

(Step 1) Required data

Machine used	: Agitator
Type of shock	: Moderate shock
Source of power	: Motor
Rated power	: 11 kW 1800 rpm
High speed shaft	: Shaft diameter 45mm 90 rpm
Low speed shaft	: Shaft diameter 60mm 30 rpm
Distance between shafts	: 350 mm
Space limitation	: 700 mm

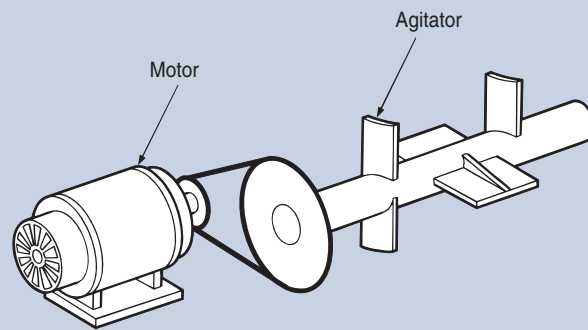

(Step 2) Determine the service factor

Service factor $K_s = 1.3$ from Table 2 Service Factor

(Step 3) Determine the design kW

Design kW = 11 kW X 1.3 = 14.3 kW

(Steps 4 and 5) Determine the chain and the number of teeth for the sprocket

Decide on the chain number and number of teeth of the small sprocket derived from the speed of the high speed shaft, at 90 rpm, and the design kW (14.3 kW).

(1) 17T for single strand RS100 is derived from the basic selection figure and the kilowatt ratings table. Since the speed ratio is 1/3, the number of teeth will be 17T and 51T for RS100. But, with an outer diameter of 17T at 189 mm and 51T at 534 mm, these are not adequate because they do not fit in the required space. $\therefore 189 + 534 > 700$

(2) Checking multi-strand chains:

- 19T and 57T for RS80-2 is derived with double-strand chain, and the outer diameter of its sprockets are 167 mm and 476 mm, which is within limits. Check RS80 kilowatt ratings table for the kW ratings of 19T for RS80-2.
- The kW ratings for the small sprocket number of teeth (19T) is 5.06 kW at 50 rpm, and 9.44 kW at 100 rpm. By calculating proportionally using the differences in their tables, drive kW for 90 rpm is 8.56 kW.

(3) This 8.56 kW is the kilowatt rating of single-strand chain, and the kilowatt rating of double-strand chain that will be used is derived from the multi-strand factor in Table 1.

8.56 kW X 1.7 = 14.6 kW

(4) This kW rating, 14.6 kW, satisfies the design kW (14.3 kW).

(Step 6) Check the bore diameter

(1) Check the bore diameter on the dimension table. Maximum bore diameter for RS80-2-19T is 63 mm, and it can be used for the required bore diameter of 45 mm.

Maximum bore diameter for RS80-2-57T is 80 mm, and it can be used for the 60 mm.

(Step 7) Determine the distance between shafts

With a distance between shafts of 350 mm,

$\frac{(167 + 476)}{2} < 350$, and it will fit into the required space.

Number of the links is calculated as

$$L = \frac{57 + 19}{2} + 2 \times \frac{350}{25.4} + \frac{\left(\frac{57 - 19}{6.28}\right)^2}{\frac{350}{25.4}} = 68.2$$

In order to have an even number of links, raise the value to the right of the decimal point to an integer to get 70.

(Step 8) Check lubrication method

Since the small sprocket is RS80-2-19T at a speed of 90 rpm, according to the kilowatt ratings table, lubrication method A will be used. It is necessary to use oil bath lubrication or lubrication with a slinger disc.

For selecting lifting or shuttle traction applications, do not use the General Selection method. Use the Allowable Load Selection method.

Reason: It is assumed that the braking force will be large when a balance weight is used, even if the motor capacity is small.

Roller Chain Selection

6. Allowable Load Selection Method

Procedures

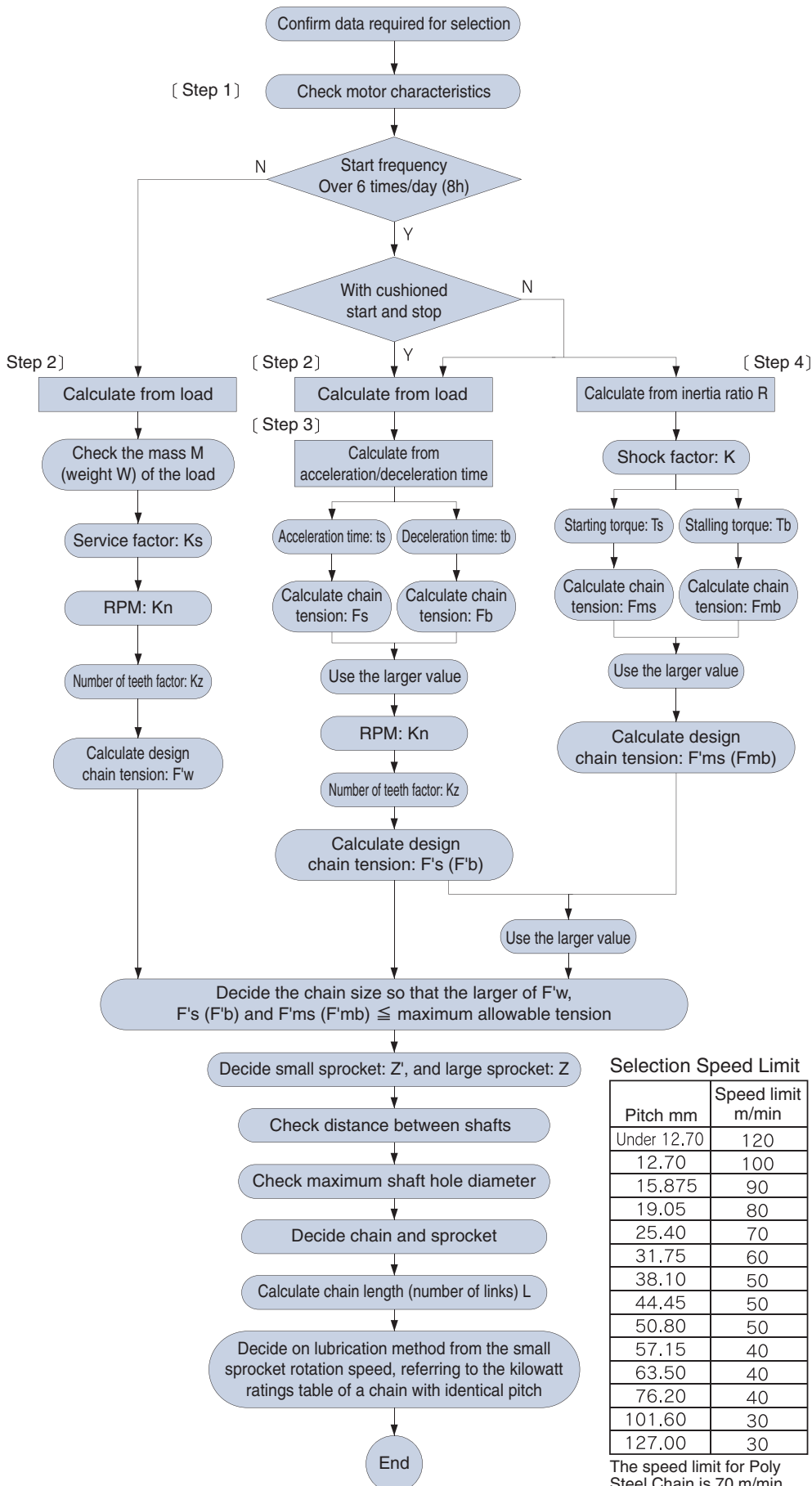

Selection Speed Limit

Pitch mm	Speed limit m/min
Under 12.70	120
12.70	100
15.875	90
19.05	80
25.40	70
31.75	60
38.10	50
44.45	50
50.80	50
57.15	40
63.50	40
76.20	40
101.60	30
127.00	30

The speed limit for Poly Steel Chain is 70 m/min.

The following selection method uses maximum allowable load for products with no kilowatt ratings tables, or for products operated at low speeds with frequent stops.

(1) For transmission with large shocks and other extreme conditions, in particular large-load transmission and transmission where a thrust load may operate, use F-type connecting links or two-pitch offset links.

(2) When using a one-pitch offset link, or a Super Chain 4 pitch offset link, make the following allowances for strength with respect to the maximum allowable load
 M-type CL*: 100%
 F-type CL: 100%
 Two-pitch offset link: 100% (Reference)
 One-pitch offset link: 65%
 4 pitch offset link: 90% (Super Chain single strand)
 One and two-pitch offset link: 60% (BS/DIN Chain)

(3) There is a possibility that the rim or boss of commercially available cast iron sprockets are not strong enough for the high tension of Super Chain, Super-H Roller Chain, and Ultra Super Chain. A type, B type, and C type RS sprockets are suitably strong. (Use SS400, S35C, SC450, etc.)

(4) For high-speed sprockets, use a sprocket with hardened tooth tips.

(5) Be sure to lubricate roller chain, as the bearing pressure rises very high.

* Allow an 80% reduction for M type connecting links for RS15, 25, 37, 38, 41, BF25-H, 05B, 06B, 48B, 56B and RS-KT Corrosion Resistant roller chain.

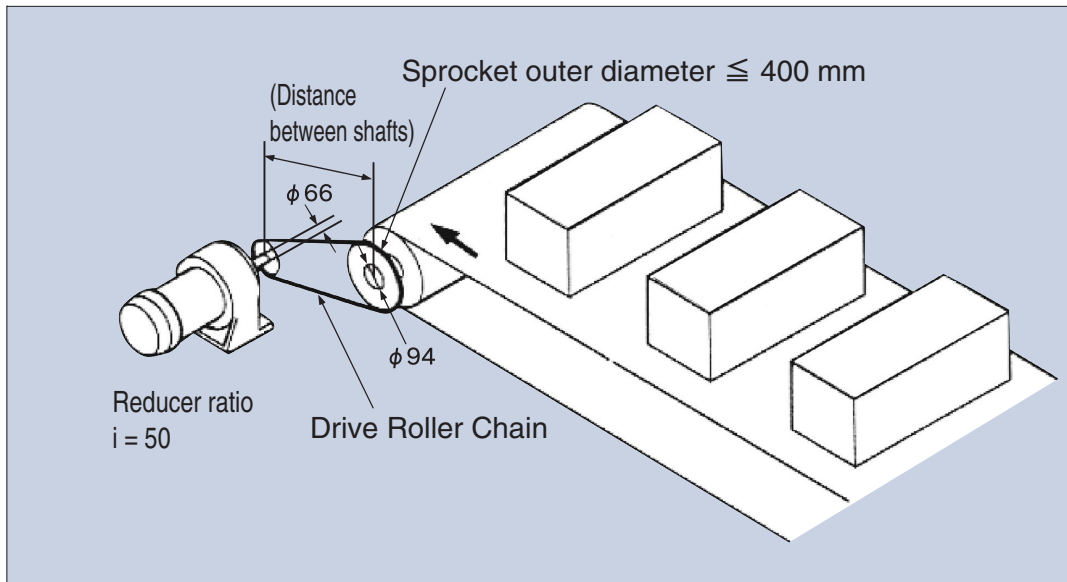

Conditions

Machine used: Conveyor drive

Chain load M: 6000 kg

Chain speed: 30 m/min

Conveyor roller diameter: 380 mm

Belt thickness: 10 mm

Conveyor roller rotation torque: 3.3 kN/m (337 kg/m)

Motor : 11 kW n₁ = 1800 rpm

Start torque 200%

Stop (maximum) torque 210%

Moment of inertia 0.088 kg/m²(GD² 0.352 kgf/m²)

Reducer ratio: 1/50 (i = 50)

Drive shaft diameter: 66 mm

Driven shaft diameter: 94 mm

Distance b/w shafts: 500 mm

Driven sprocket diameter ≤ 400 mm

Starting frequency: 10 times/day

Type of shock: Moderate shock

Soft start/stop: None

SI Units

(Step 1) Check motor characteristics

$$\text{Rated torque } T_n = 9.55 \times \frac{\text{kW}}{n_1} = 9.55 \times \frac{11}{1800} = 0.058 \text{ (kN} \cdot \text{m)}$$

$$\text{Starting torque } T_s = T_n \times 2 = 0.058 \times 2 = 0.116 \text{ (kN} \cdot \text{m)}$$

$$\text{Stalling torque } T_b = T_n \times 2.1 = 0.058 \times 2.1 = 0.122 \text{ (kN} \cdot \text{m)}$$

$$\text{Motor moment of inertia } I_m = 0.088 \text{ (kg} \cdot \text{m}^2)$$

(Step 2) Calculate from load

$$\text{Driven shaft revolution } n_2 = \text{Speed of transport} \times \frac{1000}{(\text{External diameter of conveyor roller} + 2 \times \text{Belt thickness}) \times \pi}$$

$$= 30 \times \frac{1000}{(380 + 20) \times \pi} = 23.9 \text{ (r/min)}$$

$$\text{Drive shaft revolution } n = \text{Motor rotation} / i = \frac{1800}{50} = 36 \text{ (r/min)}$$

$$\text{Chain reducer ratio} = \frac{23.9}{36} = \frac{1}{1.51}$$

If the driven sprocket d₂ = 400 mm

$$\begin{aligned} \text{Chain tension } F_w &= \text{Conveyor roller rotation torque} \times 1000 \times \frac{2}{d_2} \\ &= 3.3 \times 1000 \times \frac{2}{400} = 16.5 \text{ (kN)} \end{aligned}$$

Tentatively select the chain.

With moderate shock Usage factor K_s = 1.3Tentative design chain tension = F_w × K_s = 16.5 × 1.3 = 21.5 (kN)

Tentatively select RS120-1 with a maximum allowable load of 30.4 kN.

{Gravimetric units}

(Step 1) Check motor characteristics

$$\text{Rated torque } T_n = 9.74 \times \frac{\text{kW}}{n_1} = 9.74 \times \frac{11}{1800} = 5.95 \text{ (kgf} \cdot \text{m)}$$

$$\text{Starting torque } T_s = T_n \times 2 = 5.95 \times 2 = 11.9 \text{ (kgf} \cdot \text{m)}$$

$$\text{Stalling torque } T_b = T_n \times 2.1 = 5.95 \times 2.1 = 12.5 \text{ (kgf} \cdot \text{m)}$$

$$\text{GD}^2 \text{ of the motor } \text{GD}^2_m = 0.352 \text{ (kgf} \cdot \text{m}^2)$$

(Step 2) Calculate from load

$$\text{Driven shaft revolution } n_2 = \text{Speed of transport} \times \frac{1000}{(\text{External diameter of conveyor roller} + 2 \times \text{Belt thickness}) \times \pi}$$

$$= 30 \times \frac{1000}{(380 + 20) \times \pi} = 23.9 \text{ (r/min)}$$

$$\text{Drive shaft revolution } n = \text{Motor rotation} / i = \frac{1800}{50} = 36 \text{ (r/min)}$$

$$\text{Chain reducer ratio} = \frac{23.9}{36} = \frac{1}{1.51}$$

If the driven sprocket d₂ = 400 mm

$$\begin{aligned} \text{Chain tension } F_w &= \text{Conveyor roller rotation torque} \times 1000 \times \frac{2}{d_2} \\ &= 337 \times 1000 \times \frac{2}{400} = 1690 \text{ (kgf)} \end{aligned}$$

Tentatively select the chain.

With moderate shock Usage factor K_s = 1.3Tentative design chain tension = F_w × K_s = 1690 × 1.3 = 2200 (kgf)

Tentatively select RS120-1 with a maximum allowable load of 3100 kgf.

Roller Chain Selection

31T from driven sprocket < 400mm
 Outer diameter 398 mm PCD d₂=376.60 (mm)
 Number of teeth of drive sprocket = $\frac{31}{1.51} = 21$ T PCD d=255.63 (mm)
 Chain speed = $\frac{P \times Z' \times n}{1000} = \frac{38.1 \times 21 \times 36}{1000} = 28.8$ m/min < 50 m/min,

so it is possible to select by allowable load.
 Small sprocket revolution 36r/min ··· · RPM Kn=1.03
 Number of teeth of small sprocket 21T ··· · Number of teeth factor Kz=1.10

Chain tension F_w = Conveyor roller rotation torque × 1000 × $\frac{2}{d_2}$
 $= 3.3 \times 1000 \times \frac{2}{376.6} = 17.5$ (kN)

Design chain tension F'_w = F_w × K_s × K_n × K_z
 $= 17.5 \times 1.3 \times 1.03 \times 1.10 = 25.8$ (kN) ··· ①

RS120-1 (Max. allowable load: 30.4kN) can be used.
 Check the conveyance speed (selection conditions, 30 m/min)

Conveyance speed at this point = $n_2 \times \frac{(\text{Conveyor roller external diameter} + 2 \times \text{Belt thickness}) \times \pi}{1000}$
 $= n_1 \times \frac{21}{31} \times \frac{(\text{Conveyor roller external diameter} + 2 \times \text{Belt}) \times \pi}{1000}$
 $= 36 \times \frac{21}{31} \times \frac{(380 + 2 \times 10) \times \pi}{1000}$
 $= 30.6$ (m/min)

(Step 3) Calculate from acceleration/deceleration time

The small sprocket was decided as RS120 21T from the calculations in step 2.
 Thus, calculate using the same pitch and number of teeth.
 If the acceleration/deceleration time is known, use that value for the calculation.
 The following is calculated assuming it is unknown.

Working torque T_m = $\frac{(T_s + T_b)}{2} = \frac{(0.116 + 0.122)}{2} = 0.119$ (kN · m)
 Load torque T_ℓ = F_w × $\frac{d}{(2 \times 1000 \times i)} = 17.5 \times \frac{255.63}{(2 \times 1000 \times 50)} = 0.045$ (kN · m)

Motor shaft conversion moment of inertia I_ℓ of load side

$I_{\ell} = M \times \left(\frac{\text{Conveyance speed}}{2 \times \pi \times n_1} \right)^2$
 $= 6000 \times \left(\frac{30.6}{2 \times \pi \times 1800} \right)^2$
 $= 0.044$ (kg · m²)

Moment of inertia of the motor I_m = 0.088 (kg · m²)

Acceleration time of the motor
 $t_s = (I_m + I_{\ell}) \times \frac{n_1}{9550 \times (T_m - T_{\ell})}$
 $= (0.088 + 0.044) \times \frac{1800}{9550 \times (0.119 - 0.045)}$
 $= 0.34$ (s)

Deceleration time of the motor

$t_b = (I_m + I_{\ell}) \times \frac{n_1}{9550 \times (T_m + T_{\ell})}$
 $= (0.088 + 0.044) \times \frac{1800}{9550 \times (0.119 + 0.045)}$
 $= 0.15$ (s)

As t_b < t_s, chain tension during deceleration F_b is larger than chain tension during acceleration F_s. Thus, use the following.

Chain tension during deceleration
 $F_b = M \times \frac{\text{Conveyance speed}}{(t_b \times 60 \times 1000)} \times \frac{(\text{Conveyor roller external diameter} + 2 \times \text{Belt thickness})}{d_2} + F_w$
 $= 6000 \times \frac{30.6}{(0.15 \times 60 \times 1000)} \times \frac{(380 + 2 \times 10)}{376.6} + 17.5$
 $= 39.2$ (kN)

31T from driven sprocket < 400mm
 Outer diameter 398 mm PCD d₂=376.60 (mm)
 Number of teeth of drive sprocket = $\frac{31}{1.51} = 21$ T PCD d=255.63 (mm)
 Chain speed = $\frac{P \times Z' \times n}{1000} = \frac{38.1 \times 21 \times 36}{1000} = 28.8$ m/min < 50 m/min,

so it is possible to select by allowable load.
 Small sprocket revolution 36r/min ··· · RPM Kn=1.03
 Number of teeth of small sprocket 21T ··· · Number of teeth factor Kz=1.10

Chain tension F_w = Conveyor roller rotation torque × 1000 × $\frac{2}{d_2}$
 $= 337 \times 1000 \times \frac{2}{376.6} = 1790$ (kgf)

Design chain tension F'_w = F_w × K_s × K_n × K_z
 $= 1790 \times 1.3 \times 1.03 \times 1.10 = 2640$ (kgf) ··· ①

RS120-1 (Max. allowable load: 3100kgf) can be used.
 Check the conveyance speed (selection condition 30s, m/min)

Conveyance speed at this point = $n_2 \times \frac{(\text{Conveyor roller external diameter} + 2 \times \text{Belt thickness}) \times \pi}{1000}$
 $= n_1 \times \frac{21}{31} \times \frac{(\text{Conveyor roller external diameter} + 2 \times \text{Belt}) \times \pi}{1000}$
 $= 36 \times \frac{21}{31} \times \frac{(380 + 2 \times 10) \times \pi}{1000}$
 $= 30.6$ (m/min)

(Step 3) Calculate from acceleration/deceleration time

The small sprocket was decided as RS120 21T from the calculations in step 2.
 Thus, calculate using the same pitch and number of teeth.
 If the acceleration/deceleration time is known, use that value for the calculation.
 The following is calculated assuming it is unknown.

Working torque T_m = $\frac{(T_s + T_b)}{2} = \frac{(11.9 + 12.5)}{2} = 12.2$ (kgf · m)
 Load torque T_ℓ = F_w × $\frac{d}{(2 \times 1000 \times i)} = 1790 \times \frac{255.63}{(2 \times 1000 \times 50)} = 4.58$ (kgf · m)

Motor shaft conversion GD² of the load side

$GD^2_{\ell} = M \times \left(\frac{\text{Conveyance speed}}{\pi \times n_1} \right)^2$
 $= 6000 \times \left(\frac{30.6}{\pi \times 1800} \right)^2$
 $= 0.176$ (kgf · m²)

GD² of the motor GD²_m = 0.352 (kgf · m²)

Acceleration time of the motor
 $t_s = (GD^2_m + GD^2_{\ell}) \times \frac{n_1}{375 \times (T_m - T_{\ell})}$
 $= (0.352 + 0.176) \times \frac{1800}{375 \times (12.2 - 4.58)}$
 $= 0.34$ (s)

Deceleration time of the motor

$t_b = (GD^2_m + GD^2_{\ell}) \times \frac{n_1}{375 \times (T_m + T_{\ell})}$
 $= (0.352 + 0.176) \times \frac{1800}{375 \times (12.2 + 4.58)}$
 $= 0.34$ (s)

As t_b < t_s, chain tension during deceleration F_b is larger than chain tension during acceleration F_s. Thus, use the following.

Chain tension during deceleration
 $F_b = M \times \frac{\text{Conveyance speed}}{(t_b \times 60 \times G)} \times \frac{(\text{Conveyor roller external diameter} + 2 \times \text{Belt thickness})}{d_2} + F_w$
 $= 6000 \times \frac{30.6}{(0.15 \times 60 \times G)} \times \frac{(380 + 2 \times 10)}{376.6} + 1790$
 $= 4000$ (kgf)

Design chain tension

$$F'b = F_b \times K_n \times K_z = 39.2 \times 1.03 \times 1.10 = 44.4 \text{ (kN)} \cdots \cdots \textcircled{2}$$

RS120-2 (maximum allowable load 51.7 kN) or RS120-SUP-2 (maximum allowable load 66.7 kN) can be used because $F'b = 44.4 \text{ (kN)}$.

Considering RS140 18T (outer diameter 279 mm $d = 255.98$) and 27T (outer diameter 407 mm $d_2 = 382.88$) with similar PCD results conflict with the driven sprocket external diameter ≤ 400 mm, they cannot be used.

Chain reduction ratio becomes $\frac{36}{23.9}$ from the required $\frac{26}{18}$, and conveyance speed $= 30 \times \frac{36}{23.9} \times \frac{18}{26} = 31.3 \text{ m/min}$,

but upon examination 26T (outer diameter 393 mm $d_2 = 368.77$)

$\textcircled{2}$ is $F'b = 46.3 \text{ (kN)}$

RS140-1 cannot be used because its maximum allowable load is 40.2 kN.

RS140-SUP-1 can be used because its maximum allowable load is 53.9 kN.

Since the sprocket bore diameter of 18T is up to 89 mm, and for 26T is up to 103 mm, it can be used with a drive shaft diameter of 66 mm and driven shaft diameter of 94 mm.

With the distance between shafts at 500 mm, a sprocket with 18T ($d = 255.98$) and 26T ($d_2 = 368.77$) can be used.

Number of links will be 46 links.

Lubrication for RS140-SUP-1 should be oil bath or lubrication using a slinger disc as per the kilowatt ratings table.

(Step 4) Calculate from inertia ratio R

$$\text{Inertia ratio } R = \frac{I \ell}{I_m} = \frac{0.044}{0.088} = 0.5$$

There is clearance in the drive equipment $\cdots \cdots$ Shock factor $K = 1.0$

Starting torque $T_s = 0.116 \text{ (kN} \cdot \text{m)}$

Chain tension from starting torque

$$\begin{aligned} F_{ms} &= T_s \times i \times 1000 \times \frac{2}{d} \\ &= 0.116 \times 50 \times 1000 \times \frac{2}{255.63} = 45.4 \text{ (kN)} \end{aligned}$$

Stalling torque $T_b = 0.122 \text{ (kN} \cdot \text{m)}$

Chain tension from stalling torque

$$\begin{aligned} F_{mb} &= T_b \times i \times 1.2 \times 1000 \times \frac{2}{d} \\ &= 0.122 \times 50 \times 1.2 \times 1000 \times \frac{2}{255.63} = 57.3 \text{ (kN)} \end{aligned}$$

Since $F_{mb} > F_{ms}$, use the larger F_{mb} .

Design chain tension

$$F'm_b = F_{mb} \times K \times K_n \times K_z = 57.3 \times 1.0 \times 1.03 \times 1.10 = 64.9 \text{ (kN)} \cdots \cdots \textcircled{3}$$

Comparing $\textcircled{1}$, $\textcircled{2}$, and $\textcircled{3}$, $\textcircled{3}$ is the largest.

Since $F'm_b = 64.3 \text{ (kN)}$, RS120-3 (maximum allowable load 76.0 kN) or RS120-SUP-2 (maximum allowable load 66.7 kN) is usable.

With the distance between shafts at 500 mm, a sprocket with 21T ($d = 255.63$) and 31T ($d_2 = 376.60$) can be used.

Number of links will be 54 links.

Lubrication for both RS120-1 and RS120-SUP-1 should be oil bath or lubrication by slinger disc as per the kilowatt ratings table.

Design chain tension

$$F'b = F_b \times K_n \times K_z = 4000 \times 1.03 \times 1.10 = 4530 \text{ (kgf)} \cdots \cdots \textcircled{2}$$

RS120-2 (maximum allowable load 5270 kgf) or RS120-SUP-2 (maximum allowable load 6800 kgf) can be used because $F'b = 4530 \text{ (kgf)}$.

Considering RS140 18T (outer diameter 279 mm $d = 255.98$) and 27T (outer diameter 407 mm $d_2 = 382.88$) with similar PCD results conflict with the driven sprocket external diameter ≤ 400 mm, they cannot be used.

Chain reduction ratio becomes $\frac{36}{23.9}$ from the required $\frac{26}{18}$, and conveyance speed $= 30 \times \frac{36}{23.9} \times \frac{18}{26} = 31.3 \text{ m/min}$,

but upon examination 26T (outer diameter 393 mm $d_2 = 368.77$)

$\textcircled{2}$ is $F'b = 4720 \text{ (kgf)}$

RS140-1 cannot be used because its maximum allowable load is 4100 kgf.

RS140-SUP-1 can be used because its maximum allowable load is 5500 kgf.

Since the sprocket bore diameter of 18T is up to 89 mm, and for 26T is up to 103 mm, it can be used with a drive shaft diameter of 66 mm and driven shaft diameter of 94 mm.

With the distance between shafts at 500 mm, a sprocket with 18T ($d = 255.98$) and 26T ($d_2 = 368.77$) can be used.

Number of links will be 46 links.

Lubrication for RS140-SUP-1 should be oil bath or lubrication using a slinger disc as per the kilowatt ratings table.

(Step 4) Calculate from inertia ratio R

$$\text{Inertia ratio } R = \frac{GD^2 \ell}{GD^2 m} = \frac{0.176}{0.352} = 0.5$$

There is clearance in the drive equipment $\cdots \cdots$ Shock factor $K = 1.0$

Starting torque $T_s = 11.9 \text{ (kgf} \cdot \text{m)}$

Chain tension from starting torque

$$\begin{aligned} F_{ms} &= T_s \times i \times 1000 \times \frac{2}{d} \\ &= 11.9 \times 50 \times 1000 \times \frac{2}{255.63} = 4660 \text{ (kgf)} \end{aligned}$$

Stalling torque $T_b = 12.5 \text{ (kgf} \cdot \text{m)}$

Chain tension from stalling torque

$$\begin{aligned} F_{mb} &= T_b \times i \times 1.2 \times 1000 \times \frac{2}{d} \\ &= 12.5 \times 50 \times 1.2 \times 1000 \times \frac{2}{255.63} = 5870 \text{ (kgf)} \end{aligned}$$

Since $F_{mb} > F_{ms}$, use the larger F_{mb} .

Design chain tension

$$F'm_b = F_{mb} \times K \times K_n \times K_z = 5870 \times 1.0 \times 1.03 \times 1.10 = 6650 \text{ (kgf)} \cdots \cdots \textcircled{3}$$

Comparing $\textcircled{1}$, $\textcircled{2}$, and $\textcircled{3}$, $\textcircled{3}$ is the largest.

Since $F'm_b = 6650 \text{ (kgf)}$, RS120-3 (maximum allowable load 7750 kgf) or RS120-SUP-2 (maximum allowable load 6800 kgf) is usable.

With the distance between shafts at 500 mm, a sprocket with 21T ($d = 255.63$) and 31T ($d_2 = 376.60$) can be used.

Number of links will be 54 links.

Lubrication for both RS120-1 and RS120-SUP-1 should be oil bath or lubrication by slinger disc as per the kilowatt ratings table.

Roller Chain Selection

Considering RS160 15T (outer diameter 269mm $d=244.33$) and 23T (outer diameter 400mm $d_2=373.07$) with similar PCD,

③ $F_{mb}=69.0(kN)$ will be largest.

RS160-1 cannot be used because its maximum allowable load is 53.0 kN.

RS160-SUP-1 can be used because its maximum allowable load is 70.6kN.

Since a sprocket bore diameter with 15T is up to 95mm, and 23T is up to 118mm, it can be used for a drive shaft diameter of 66mm, and driven shaft diameter of 94mm.

With the distance between shafts at 500mm, a sprocket with 15T ($d=244.33$) and 23T ($d_2=373.07$) can be used.

Number of links will be 42 links.

Lubrication for RS140-SUP-1 should be oil bath or lubrication by slinger disc as per kilowatt ratings table.

Considering RS160 15T (outer diameter 269mm $d=244.33$) and 23T (outer diameter 400mm $d_2=373.07$) with similar PCD,

③ $F_{mb}=7040(kgf)$ will be largest.

RS160-1 cannot be used because its maximum allowable load is 5400kgf.

RS160-SUP-1 can be used because its maximum allowable load is 7200kgf.

Since a sprocket bore diameter with 15T is up to 95mm, and 23T is up to 118mm, it can be used for a drive shaft diameter of 66mm, and driven shaft diameter of 94mm.

With the distance between shafts at 500mm, a sprocket with 15T ($d=244.33$) and 23T ($d_2=373.07$) can be used.

Number of links will be 42 links.

Lubrication for RS140-SUP-1 should be oil bath or lubrication by slinger disc as per kilowatt ratings table.

Measurement results

Condition	Step	Chain size	Sprocket	Number of links	Lubrication class
Start frequency 6 times or less	Step 2	RS120-1	21T×31T	54 links	B
Start frequency 6 times or more with cushion start	Step 3	RS120-2	21T×31T	54 links	B
		RS140-1	18T×26T	46 links	B
Start frequency 6 times or more without cushion start	Step 3	RS120-3	21T×31T	54 links	B
		RS120-SUP-2			B
	Step 4	RS160-SUP-1	15T×23T	42 links	B

Lubrication class B: Lubrication with oil bath or slinger disc
All shaft distances need to be adjusted.

7. Example of lifting transmissions

There are many examples of where chain is used for lifting. By making use of Roller Chain features, choosing the right chain and following some important points, it is possible to use Roller Chain for lifting transmissions. Typical lifting applications are illustrated below. (Please give special consideration to safety devices.)

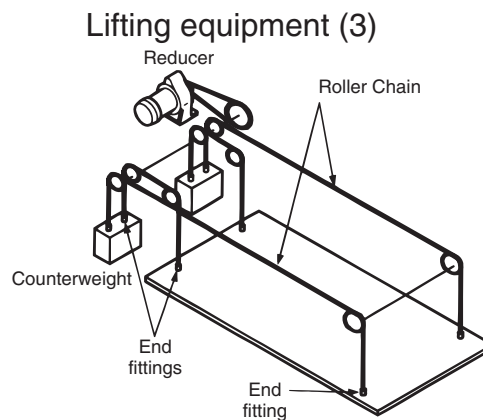
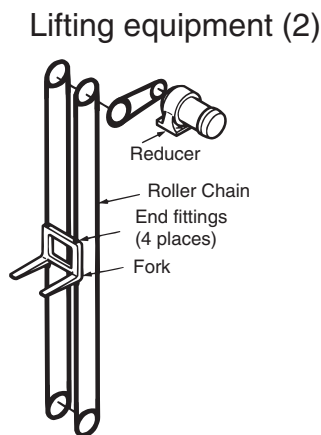
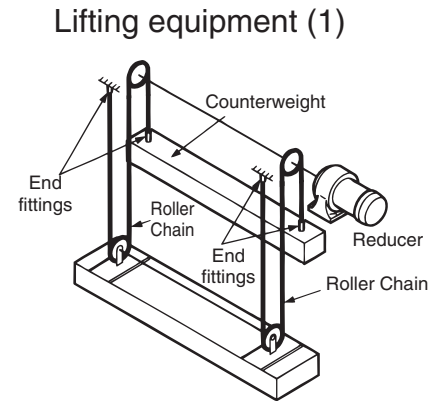
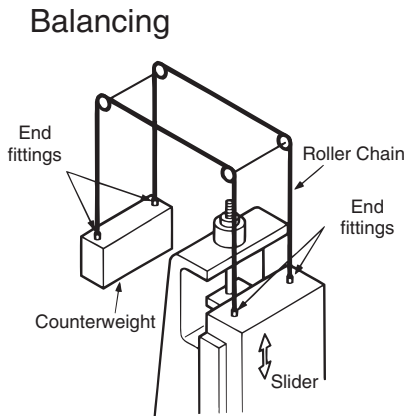

⚠ Selecting hanging roller chain

- ① If there are any laws or guidelines for chain selection, check and calculate accordingly. Make sure to follow the manufacturer's selections and select the safer of the two selections.
- ② Use F-type (semi press-fit) connecting links. Offset links cannot be used.
- ③ Lubricate the chain joints as much as possible after you reduce the loads. Sufficient lubrication is also required at end fittings (end bolts and connecting links, etc.) and connecting parts, etc.

Roller Chain Selection

Weight required for counterweight to prevent sprocket tooth-jumping when using Roller Chain in lifting transmission applications

$$T_k = T_o \times \left\{ \frac{\sin \phi}{\sin (\phi + 2\alpha)} \right\}^{K-1}$$

T_k : Minimum weight tension (minimum back-tension)

T_o : Roller Chain tension

ϕ : Sprocket minimum pressure angle $\phi = 17^\circ - \frac{64^\circ}{N}$

2α : Sprocket dividing angle $2\alpha = \frac{360^\circ}{N}$

K : Engaging no. of teeth $K = \frac{\theta}{360^\circ} \times N \dots$ Round up to the nearest whole number to be safe.

If $t_o = 1100\text{kgf}$, $N = 13$, and $\theta = 120^\circ$, then

$$\phi = 17^\circ - \frac{64^\circ}{N} = 17^\circ - \frac{64^\circ}{13} = 12.077$$

$$2\alpha = \frac{360^\circ}{N} = \frac{360^\circ}{13} = 27.692$$

$$K = \frac{\theta}{360^\circ} \times N = \frac{120^\circ}{360^\circ} \times 13 = 4.33 \dots K = 4$$

$$T_k = 1100 \times \left\{ \frac{\sin 12.077}{\sin (12.077 + 27.692)} \right\}^{4-1} = 38.5 \text{ (kg)}$$

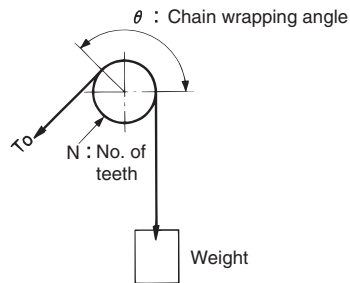

Accordingly, tooth-jumping will not occur if a 39 kg weight is used. However, this will change depending on the layout and amount of wear on the Roller Chain and sprocket teeth. Please use the above as a reference.

8. Calculating moment of inertia (Table 6)

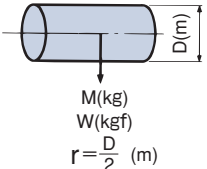
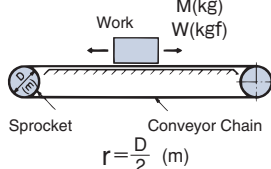
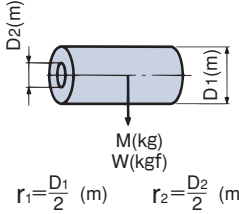
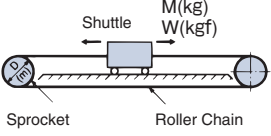
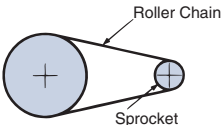
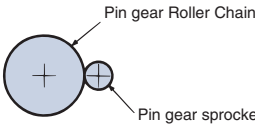
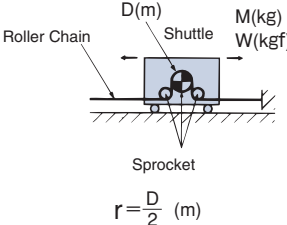
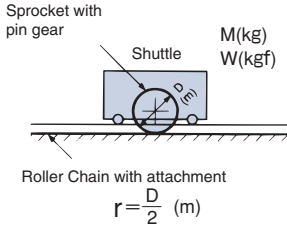
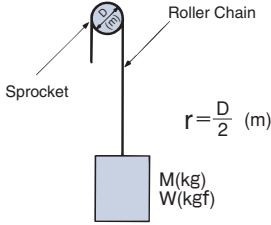
Rotating Body	(Moment of inertia) Calculation Method (SI Unit)	$\left\{ \begin{array}{l} \text{GD}^2 \text{ Calculation} \\ \text{Method (Gravimetric Unit)} \end{array} \right\}$	Linear Body	(Moment of inertia) Calculation Method (SI Unit)	$\left\{ \begin{array}{l} \text{GD}^2 \text{ Calculation} \\ \text{Method (Gravimetric Unit)} \end{array} \right\}$						
<p>Right cylinder</p>  <p>$I = \frac{1}{2}Mr^2$ ($\text{kg} \cdot \text{m}^2$)</p> <p>$GD^2 = \frac{1}{2}WD^2$ ($\text{kgf} \cdot \text{m}^2$)</p>			<p>Conveyor drive</p>  <p>$I = Mr^2$ ($\text{kg} \cdot \text{m}^2$)</p> <p>$GD^2 = WD^2$ ($\text{kgf} \cdot \text{m}^2$)</p>								
<p>Hollow right cylinder</p>  <p>$I = \frac{1}{2}M(r_1^2 + r_2^2)$ ($\text{kg} \cdot \text{m}^2$)</p> <p>$GD^2 = \frac{1}{2}W(D_1^2 + D_2^2)$ ($\text{kgf} \cdot \text{m}^2$)</p> <p>$r_1 = \frac{D_1}{2}$ (m) $r_2 = \frac{D_2}{2}$ (m)</p>			<p>Shuttle Traction</p>  <p>$I = Mr^2$ ($\text{kg} \cdot \text{m}^2$)</p> <p>$GD^2 = WD^2$ ($\text{kgf} \cdot \text{m}^2$)</p>								
<p>Wrapping drive</p> 		<p>Pin gear drive</p> 	<p>Pin gear drive</p>  <p>$I = Mr^2$ ($\text{kg} \cdot \text{m}^2$)</p> <p>$GD^2 = WD^2$ ($\text{kgf} \cdot \text{m}^2$)</p>								
<p>Note</p> <table border="1"> <thead> <tr> <th></th> <th>SI unit</th> <th>{Gravimetric unit}</th> </tr> </thead> <tbody> <tr> <td>Moment of inertia (I) and fly wheel effect (GD^2)</td> <td>$1 \text{ kg} \cdot \text{m}^2$ (I)</td> <td>$4 \text{ kgf} \cdot \text{m}^2$ (GD^2)</td> </tr> </tbody> </table>				SI unit	{Gravimetric unit}	Moment of inertia (I) and fly wheel effect (GD^2)	$1 \text{ kg} \cdot \text{m}^2$ (I)	$4 \text{ kgf} \cdot \text{m}^2$ (GD^2)	<p>Pin gear drive</p>  <p>$I = Mr^2$ ($\text{kg} \cdot \text{m}^2$)</p> <p>$GD^2 = WD^2$ ($\text{kgf} \cdot \text{m}^2$)</p>		
	SI unit	{Gravimetric unit}									
Moment of inertia (I) and fly wheel effect (GD^2)	$1 \text{ kg} \cdot \text{m}^2$ (I)	$4 \text{ kgf} \cdot \text{m}^2$ (GD^2)									
			<p>Lifting application</p>  <p>$I = Mr^2$ ($\text{kg} \cdot \text{m}^2$)</p> <p>$GD^2 = WD^2$ ($\text{kgf} \cdot \text{m}^2$)</p>								
			<p>To convert moment of inertia load to motor shaft</p> <p>\mathbf{n}_1: Motor shaft rotating speed</p> <p>\mathbf{n}_2: Load shaft rotating speed</p>	<p>Moment of inertia load</p> $I \ell = \left(\frac{n_2}{n_1} \right)^2 I$ $= \frac{I}{i^2} \text{ (kg} \cdot \text{m}^2 \text{)}$ <p>Moment of inertia GD^2 load</p> $GD^2 \ell = \left(\frac{n_2}{n_1} \right)^2 GD^2$ $= \frac{GD^2}{i^2} \text{ (kgf} \cdot \text{m}^2 \text{)}$ <p>Moment of inertia GD^2 load</p> $GD^2 \ell = W \left(\frac{V}{\pi n_1} \right)^2$ $\text{(kgf} \cdot \text{m}^2 \text{)}$							

The above does not include the mass of the sprocket and chain.

Roller Chain Selection

9. Example of shuttle traction

The following are typical examples of using Roller Chain for shuttle traction. The roller chain can be attached to the shuttle with an end fitting and towed using a sprocket on one end (left figure), or the driving unit can be attached to the shuttle, with a roller chain fixed to both ends using end fittings (right figure).

There are similar ways to tow a shuttle at an angle. With the left figure the drive sprocket would be set at the top of the incline.

⊕ : Drive side

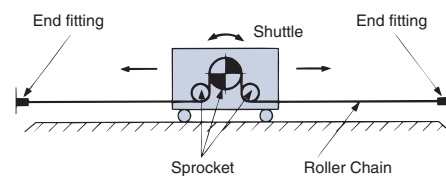
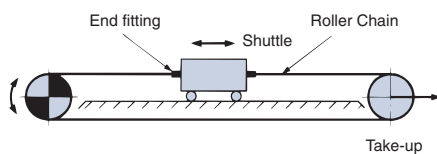

⚠ Selecting roller chain for shuttle traction

- ① If there are any laws or guidelines for chain selection, check and calculate accordingly. Make sure to follow the manufacturer's selections and select the safer of the two selections.
- ② Use F-Type (semi press-fit) connecting links. M-Type connecting links can only be used if there is minimal shock with no lateral force. Offset links cannot be used.
- ③ Lubricate the chain joints as much as possible after you reduce the loads. Sufficient lubrication is also required at end fittings (end bolts and connecting links, etc.) and connecting parts, etc.

10. Pin gear drive selection method

Generally, linear movement or large radius rotation is made possible by a roller chain and gear through a transmission source (motor, etc.) via a reducer.

A roller chain, however, needs a lot of space, and gears require precision machining, which increases the cost. A pin gear is ideal in these situations.

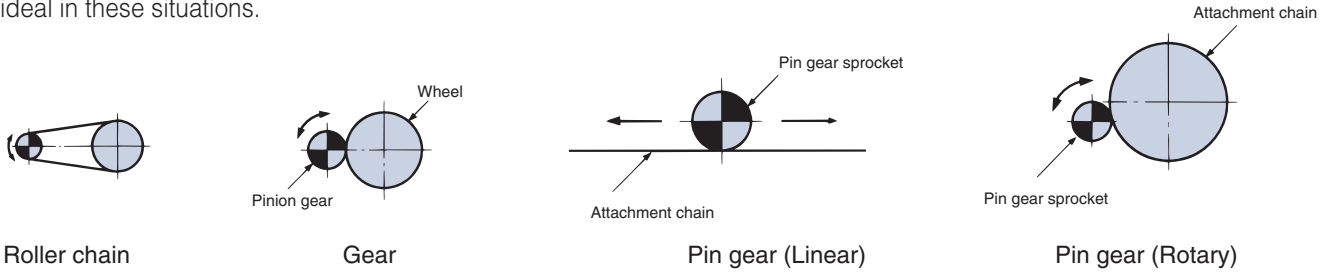

For pin gear drives, a roller chain is wrapped around the perimeter of a drum to make a wheel, and special sprockets (see Sprockets) are used instead of pinion gears. For linear motion, a roller chain is attached and used linearly instead of a rack.

Item	Pin gear drive	Roller chain transmission	Gear transmission
Restrictions on distance between shafts	Yes	No	Yes
Number of engaged teeth	Low	High	Low
Speed ratio range	No limit	Up to 1:7	No limit
Tooth shape	Special teeth	Sprocket teeth	Involute
Engagement accuracy	Normal	Normal	Precise

10.1 Characteristics of pin gears

- 1) Economical at large speed ratios (1:5 or larger), especially when the drum has a large diameter.
 - 2) Roller chain attachments are bolted onto the drum for easy installation and maintenance.
 - 3) Design freedom in drum diameter, linear length, etc.
 - 4) Rough installation accuracy and no precision machining required for gears.
 - 5) Grease lubrication can be used.
- ▲ A pin gear is not suitable for ultra precise drives, and the noise level is high compared to gears.

10.2 Chain installation and precautions

- 1) When used linearly (rack) with rollers facing up:
 - Use standard roller chain.

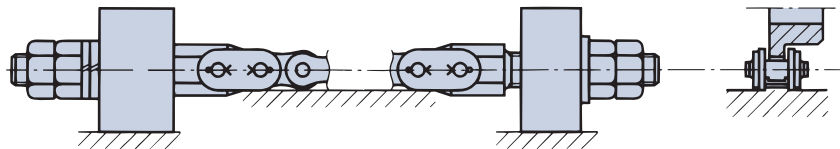

Connecting links are used on both ends, and fittings are attached and bolts and nuts are fastened to remove any slack. (Both ends need to be secured snugly with double nuts.) NOTE: This is not recommended as tooth slipping and interference can occur.

- Used an attachment roller chain.

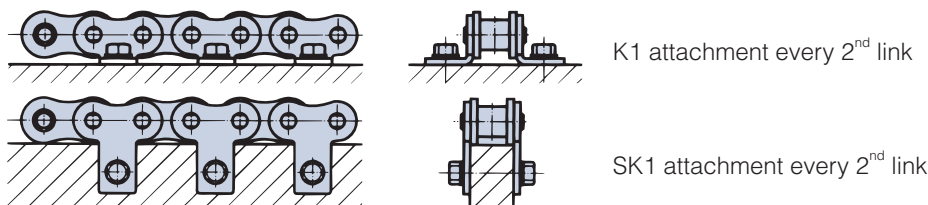

Attach K1 or SK1 attachments every 2nd link and fasten with bolts and nuts every 2nd or 4th link with chain pulled taut so there is no slack or meandering. (K attachments are recommended.) The attachment holes are usually processed on-site.

Roller Chain Selection

Use bolts with a strength class 8.8 or higher (JIS1051-2000 Tensile strength 800 N/mm² or higher). (SCM435 heat treated bolts, etc.)

- The length of the chain should be the travel distance plus α .
 α : The distance of overrun based on usage conditions.

2) When used linearly (rack) with rollers facing down:

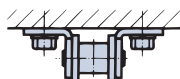
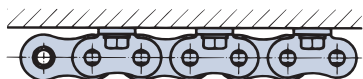

K1 attachment every 2nd link

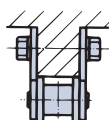
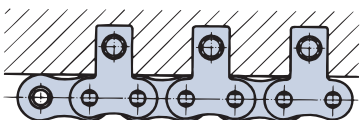

SK1 attachment every 2nd link

Attach K1 or SK1 attachments every 2nd link and fasten with bolts and nuts every 2nd or 4th link with chain pulled taut so there is no slack or meandering.

3) When wrapped partially or totally around the outside of a drum:

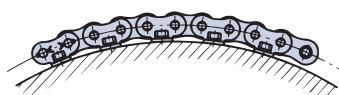

- Attachment chain length is in the range of -0.05 to 0.15% of standard length (nominal pitch x number of links). When the chain is wrapped around a drum, shims need to be used between the drum and the chain attachments to eliminate slack.
- Since K attachments can be adjusted with shims, they can be attached onto the drum more easily than SK attachments.
- When the drum is not perfectly round, the thickness of the shims needs to be adjusted while the chain is wrapped around the drum so the radius is circular. As shown below, a dial gauge or a surface gauge can be used for adjustment.
- Process tap holes to fit the holes of the chain attachments.

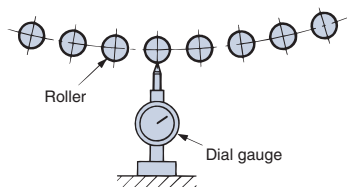

4) When wrapped partially or totally around the inside of a drum:

- Contact a Tsubaki representative.

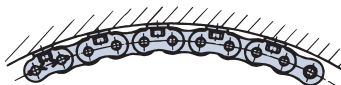

5) When used for lateral wrapping (horizontal drive)

- See section 3).
- Contact a Tsubaki representative for internal fits.

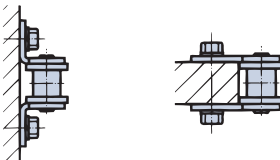

6) Sprocket attachment

- Adjust the shaft of the sprocket so that the sprocket engages the chain straight.
- The clearance (α) between the rollers and the bottom of the sprocket teeth should be less than the dimensions shown in the following table. The bottom of the teeth and rollers should not touch each other.

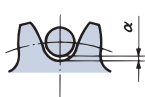
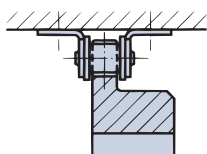

Chain size	α
RS80 or less	1.0mm
RS100 to RS180	1.5mm
RS200 or more	2.0mm

- When the bottom of the teeth and rollers touch each other in the clearance described above, the tooth form needs to be pre-designed with larger clearance α . Contact a Tsubaki representative for details.

Procedure

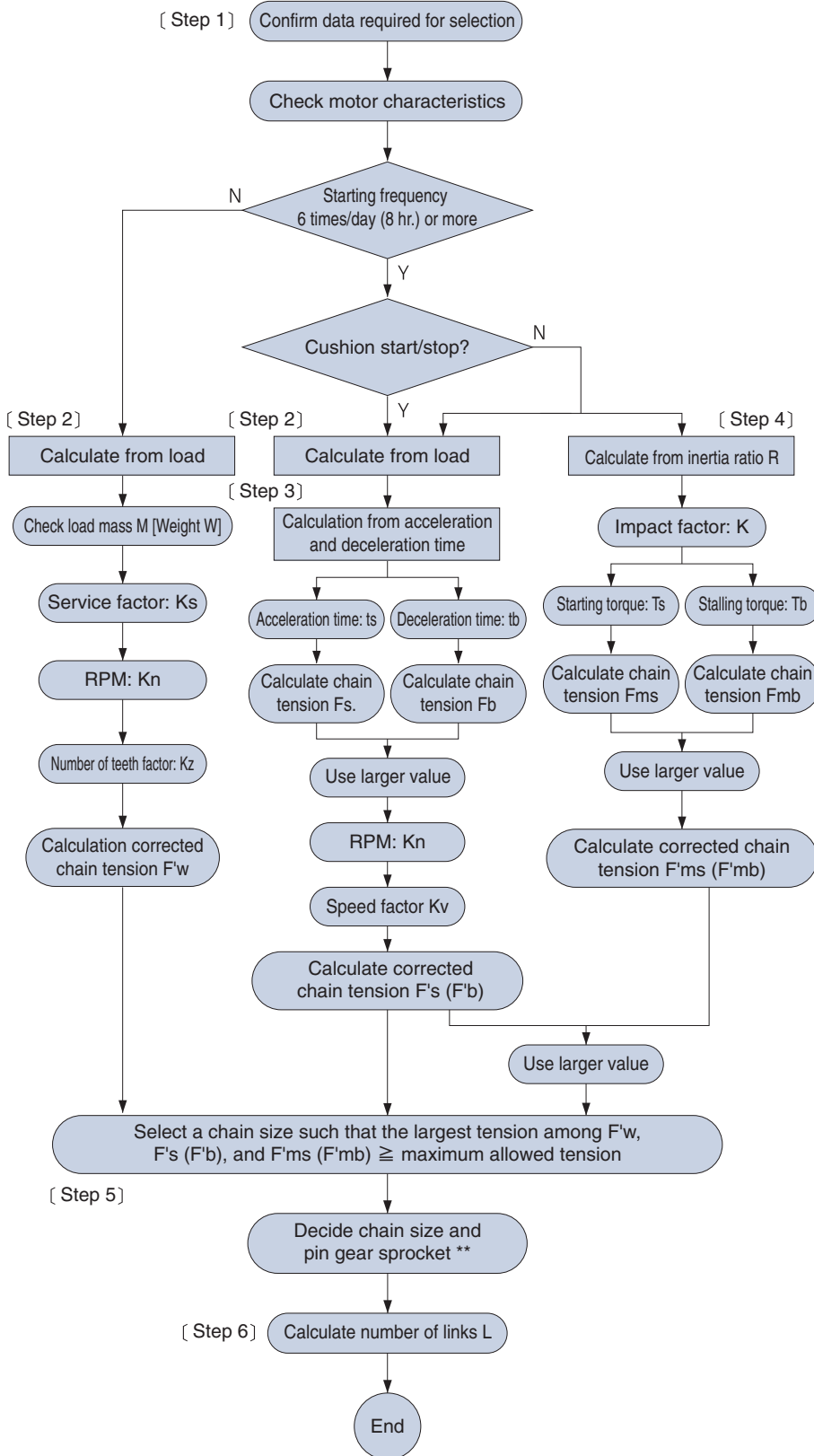

(Note) Chain relative speed V is 50 m/min or less.

(When V is greater than 50 m/min)
Linear: Roll drive, etc.
Drum: Change chain attachment
diameter → Reduce size.

Pin gear speed factor K_v

Relative chain speed	Pin gear speed factor
0 to 15 m/min	1.0
15 to 30	1.2
30 to 50	1.4

** Sprocket for pin gear drive

This sprocket is exclusively for special
tooth shapes.

$N \geq 13^{\circ}$, with $N = 18^{\circ}$ recommended.
Refer to previous sections for pin
gear drive handling.

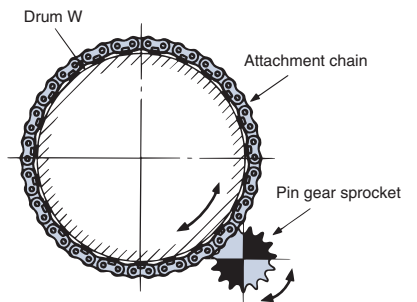
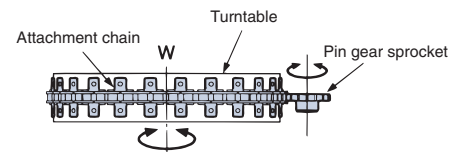
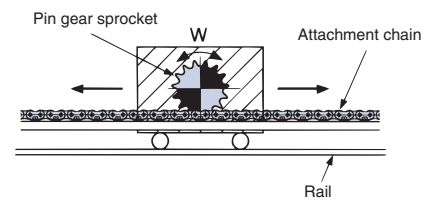
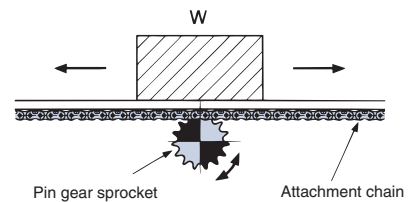

Roller Chain Selection

Pin gear drive selection example

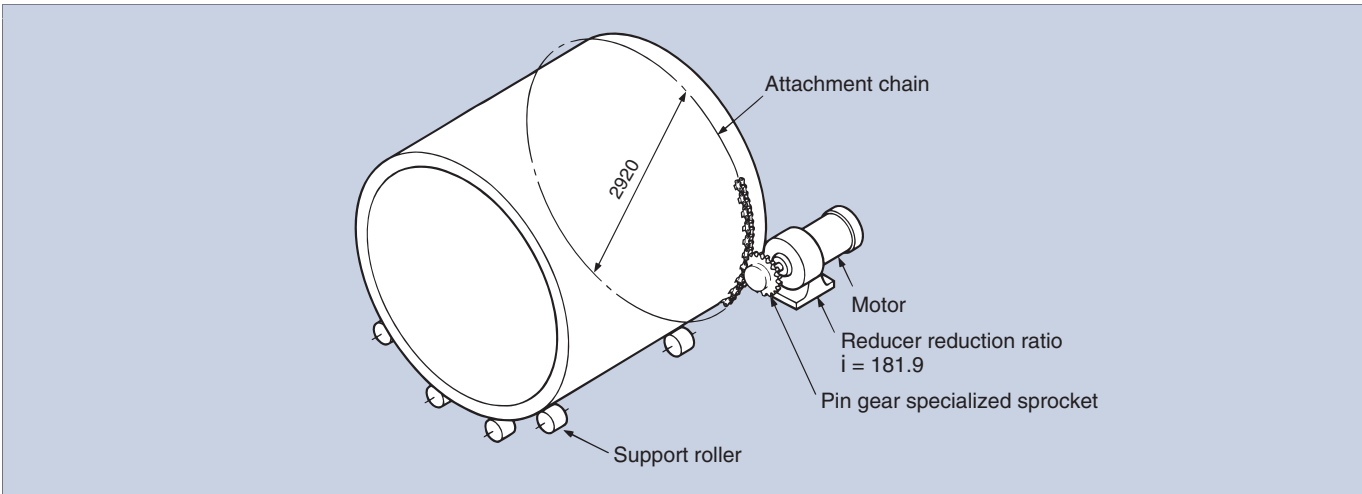

SI units

[Step 1] Check machine and motor characteristics

Machine: Cutting machine
 Motor: 15 kW, 4P, 1750 rpm

Motor moment of inertia $I : I_m = 0.00425 \text{ kg} \cdot \text{m}^2$

Starting torque $T_s \dots\dots\dots 290\%$
 Stalling torque $T_b \dots\dots\dots 305\%$
 Reducer reduction ratio $i \dots\dots\dots 181.9$
 Forward and reverse operation frequency \dots Max 900 times/hour
 Sprocket pitch circle diameter (PCD) \dots Approximately $\phi 220 \text{ mm}$

Moment of inertia for the motor shaft converted load $I : I_\ell = 0.00072 \text{ kg} \cdot \text{m}^2$
 There is no play in the chain.

[Step 2] Calculation from load

Revolution speed of the pin gear drive sprocket $n = 1750 \times \frac{1}{181.9} = 9.6 \text{ rpm}$

Relative chain speed $v = \frac{220 \times \pi \times 9.6}{1000} = 6.6 \text{ m/min}$ \dots Speed factor $K_v = 1.0$

High forward and reverse operation frequency $\dots\dots\dots$ Service factor $K_s = 1.5$

Load is calculated from the torque on the drive side as the mass of the load is unknown.

$$\begin{aligned} \text{Rated torque of the motor } T_n &= 9.55 \times \frac{\text{kW}}{n_1} \\ &= 9.55 \times \frac{1.5}{1750} \\ &= 0.00819 \text{ (kN} \cdot \text{m)} \end{aligned}$$

$$\begin{aligned} \text{Pin gear drive sprocket shaft torque} \\ T &= T_n \times i = 0.00819 \times 181.9 \\ &= 1.49 \text{ (kN} \cdot \text{m)} \end{aligned}$$

$$\begin{aligned} \text{Chain working tension } F &= \frac{2T}{d} = \frac{2 \times 1.49}{0.22} \\ &= 13.6 \text{ (kN)} \end{aligned}$$

$$\begin{aligned} \text{Design chain tension } F'w &= F \times K_s \times K_v \\ &= 13.6 \times 1.5 \times 1.0 \\ &= 20.4 \text{ (kN)} \dots\dots\dots \textcircled{1} \end{aligned}$$

{Gravimetric units}

[Step 1] Check machine and motor characteristics

Machine: Cutting machine
 Motor: 15 kW, 4P, 1750 rpm

GD^2 of the motor $GD^2 = 0.017 \text{ kgf} \cdot \text{m}^2$

Starting torque $T_s \dots\dots\dots 290\%$
 Stalling torque $T_b \dots\dots\dots 305\%$
 Reducer reduction ratio $i \dots\dots\dots 181.9$
 Forward and reverse operation frequency \dots Max 900 times/hour
 Sprocket pitch circle diameter (PCD) \dots Approximately $\phi 220 \text{ mm}$

GD^2 of the motor shaft converted load: $GD^2_\ell = 0.00072 \text{ kg} \cdot \text{m}^2$
 There is no play in the chain.

[Step 2] Calculation from load

$$\begin{aligned} \text{Rated torque of the motor } T_n &= 974 \times \frac{\text{kW}}{n_1} \\ &= 974 \times \frac{1.5}{1750} \\ &= 0.835 \text{ (kgf} \cdot \text{m)} \end{aligned}$$

$$\begin{aligned} \text{Pin gear drive sprocket shaft torque} \\ T &= T_n \times i = 0.835 \times 181.9 \\ &= 152 \text{ (kgf} \cdot \text{m)} \end{aligned}$$

$$\begin{aligned} \text{Chain working tension } F &= \frac{2T}{d} = \frac{2 \times 152}{0.22} \\ &= 1382 \text{ (kgf)} \end{aligned}$$

$$\begin{aligned} \text{Design chain tension } F'w &= F \times K_s \times K_v \\ &= 1382 \times 1.5 \times 1.0 \\ &= 2073 \text{ (kgf)} \dots\dots\dots \textcircled{1} \end{aligned}$$

Before Use Standard Roller Chains Lubrication-Free Roller Chains Heavy Duty Roller Chains Corrosion Resistant Roller Chains Specialty Roller Chains Sprockets Pin Gear Drives Accessories Selection Handling

[Step 3] Calculation based on acceleration and deceleration time

$$\begin{aligned}
 \text{Working torque } T_m &= \frac{T_s + T_b}{2 \times 100} \times T_n \\
 &= \frac{290 + 305}{2 \times 100} \times 0.00819 \\
 &= 0.0244 \text{ (kN} \cdot \text{m)}
 \end{aligned}$$

As the load is unknown, the rated torque of the motor is $T_n = T_\ell$ and the load torque $T_\ell = 0.00819 \text{ kN} \cdot \text{m}$ $\{0.835 \text{ kgf} \cdot \text{m}\}$

$$\begin{aligned}
 \text{Acceleration time } t_s &= \frac{(I_m + I_\ell) \times n}{9550 \times (T_m - T_\ell)} \\
 &= \frac{(0.00425 + 0.00072) \times 1750}{9550 \times (0.0244 - 0.00819)} \\
 &= 0.056 \text{ (s)}
 \end{aligned}$$

$$\begin{aligned}
 \text{Acceleration time } t_b &= \frac{(I_m + I_\ell) \times n}{9550 \times (T_m + T_\ell)} \\
 &= \frac{(0.00425 + 0.00072) \times 1750}{9550 \times (0.0244 + 0.00819)} \\
 &= 0.028 \text{ (s)}
 \end{aligned}$$

As the mass (weight) of the load is unknown, it is assumed that the mass M (weight W) is equivalent to the chain working tension F when a friction factor between the support roller and the rotator of 0.3 is applied.

$$M = \frac{F}{\mu} \times \frac{1000}{G} = \frac{13.6}{0.3} \times \frac{1000}{9.80665} = 4623 \text{ (kg)}$$

$$F_w = F = 13.6 \text{ (kN)} \text{ [Value calculated in step]}$$

As $t_b < t_s$,

$$\begin{aligned}
 \text{Chain tension while decelerating } F_b &= \frac{M \times V}{t_b \times 60 \times 1000} + F_w \\
 &= \frac{4623 \times 6.6}{0.028 \times 60 \times 1000} + 13.6 \\
 &= 31.8 \text{ (kN)}
 \end{aligned}$$

Design chain tension while decelerating

$$\begin{aligned}
 F'_b &= F_b \times K_v \\
 &= 31.8 \times 1.0 \\
 &= 31.8 \text{ (kN)} \dots\dots\dots \textcircled{3}
 \end{aligned}$$

[Step 4] Calculation based on the inertia ratio R

$$\begin{aligned}
 \text{Inertia ratio } R &= \frac{I_\ell}{I_m} = \frac{0.00072}{0.00425} \\
 &= 0.17
 \end{aligned}$$

According to Table 4, impact factor $K = 0.23$ (There is no play in the drive transmission equipment as $R < 0.2$, $R = 0.2$.)

Chain tension at start-up

$$\begin{aligned}
 F_{ms} &= \frac{T_s \times i}{(d/2) \times 100} \times T_n \\
 &= \frac{290 \times 181.9}{\frac{0.22}{2} \times 100} \times 0.00819 \\
 &= 39.3 \text{ (kN)}
 \end{aligned}$$

Chain tension at stop

$$\begin{aligned}
 F_{mb} &= \frac{T_b \times i}{(d/2) \times 100} \times T_n \times 1.2 \\
 &= \frac{305 \times 181.9}{\frac{0.22}{2} \times 100} \times 0.00819 \times 1.2 \\
 &= 49.6 \text{ (kN)}
 \end{aligned}$$

As $F_{ms} < F_{mb}$,

$$\begin{aligned}
 \text{Design chain tension } F'_{mb} &= F_{mb} \times K \times K_v \\
 &= 49.6 \times 0.23 \times 1.0 \\
 &= 11.4 \text{ (kN)} \dots\dots\dots \textcircled{2}
 \end{aligned}$$

[Step 3] Calculation based on acceleration and deceleration time

$$\begin{aligned}
 \text{Working torque } T_m &= \frac{T_s + T_b}{2 \times 100} \times T_n \\
 &= \frac{290 + 305}{2 \times 100} \times 0.835 \\
 &= 2.48 \text{ (kgf} \cdot \text{m)}
 \end{aligned}$$

$$\begin{aligned}
 \text{Acceleration time } t_s &= \frac{(GD^2_m + GD^2_\ell) \times n}{375 \times (T_m - T_\ell)} \\
 &= \frac{(0.017 + 0.00288) \times 1750}{375 \times (2.48 - 0.835)} \\
 &= 0.056 \text{ (s)}
 \end{aligned}$$

$$\begin{aligned}
 \text{Acceleration time } t_b &= \frac{(GD^2_m + GD^2_\ell) \times n}{375 \times (T_m + T_\ell)} \\
 &= \frac{(0.017 + 0.00288) \times 1750}{375 \times (2.48 + 0.835)} \\
 &= 0.028 \text{ (s)}
 \end{aligned}$$

$$W = \frac{F}{\mu} = \frac{1382}{0.3} = 4607 \text{ (kgf)}$$

$$F_w = F = 1382 \text{ (kgf)} \text{ [Value calculated in step]}$$

As $t_b < t_s$,

$$\begin{aligned}
 \text{Chain tension while decelerating } F_b &= \frac{W \times V}{t_b \times 60 \times G} + F_w \\
 &= \frac{4607 \times 6.6}{0.028 \times 60 \times 9.80665} + 1382 \\
 &= 3228 \text{ (kgf)}
 \end{aligned}$$

Design chain tension while decelerating

$$\begin{aligned}
 F'_b &= F_b \times K_v \\
 &= 3228 \times 1.0 \\
 &= 3228 \text{ (kgf)} \dots\dots\dots \textcircled{3}
 \end{aligned}$$

[Step 4] Calculation based on the inertia ratio R

$$\begin{aligned}
 \text{Inertia ratio } R &= \frac{GD^2_\ell}{GD^2_m} = \frac{0.00288}{0.017} \\
 &= 0.17
 \end{aligned}$$

Chain tension at start-up

$$\begin{aligned}
 F_{ms} &= \frac{T_s \times i}{(d/2) \times 100} \times T_n \\
 &= \frac{290 \times 181.9}{\frac{0.22}{2} \times 100} \times 0.835 \\
 &= 4004 \text{ (kgf)}
 \end{aligned}$$

Chain tension at stop

$$\begin{aligned}
 F_{mb} &= \frac{T_b \times i}{(d/2) \times 100} \times T_n \times 1.2 \\
 &= \frac{305 \times 181.9}{\frac{0.22}{2} \times 100} \times 0.835 \times 1.2 \\
 &= 5054 \text{ (kgf)}
 \end{aligned}$$

As $F_{ms} < F_{mb}$,

$$\begin{aligned}
 \text{Design chain tension } F'_{mb} &= F_{mb} \times K \times K_v \\
 &= 5054 \times 0.23 \times 1.0 \\
 &= 1162 \text{ (kgf)} \dots\dots\dots \textcircled{2}
 \end{aligned}$$

Roller Chain Selection

[Step 5] Comparison of ①, ②, and ③

Comparing ①, ②, and ③, an attachment chain for pin gears that meets 31.8kN [3228 kgf], the maximum working load ③ is selected.

The maximum allowable load for RS160 attachment chain, 37.3 kN [3800 kgf], is acceptable.

The number of the teeth is $N = 14T$ from the pitch circle diameter of the pin gear specialized sprocket, approximately $\phi 220$. (PCD = 231.78 mm)

Step 2 and 3 are calculated again here.

[Step 2]

$$F = \frac{2T}{d} = \frac{2 \times 1.49}{0.23178} = 12.9 \text{ (kN)}$$

$$\begin{aligned} F'w &= F \times Kv \\ &= 12.9 \times 1.0 = 12.9 \text{ (kN)} \end{aligned}$$

[Step 3]

$$\begin{aligned} F_{mb} &= \frac{T b \times i}{(d/2) \times 100} \times T n \times 1.2 \\ &= \frac{305 \times 181.9}{\frac{0.23178}{2} \times 100} \times 0.00819 \times 1.2 = 46.4 \text{ (kN)} \end{aligned}$$

$$\begin{aligned} F'_{mb} &= F_{mb} \times K \times Kv \\ &= 46.4 \times 0.23 \times 1.0 = 10.7 \text{ (kN)} \end{aligned}$$

The above selection is acceptable.

[Step 2]

$$F = \frac{2T}{d} = \frac{2 \times 152}{0.23178} = 1295 \text{ (kgf)}$$

$$\begin{aligned} F'w &= F \times Kv \\ &= 1295 \times 1.0 = 1295 \text{ (kgf)} \end{aligned}$$

[Step 3]

$$\begin{aligned} F_{mb} &= \frac{T b \times i}{(d/2) \times 100} \times T n \times 1.2 \\ &= \frac{305 \times 181.9}{\frac{0.23178}{2} \times 100} \times 0.835 \times 1.2 = 4797 \text{ (kgf)} \end{aligned}$$

$$\begin{aligned} F'_{mb} &= F_{mb} \times K \times Kv \\ &= 4797 \times 0.23 \times 1.0 = 1103 \text{ (kgf)} \end{aligned}$$

The above selection is acceptable.

[Step 6] Calculation of the number of links L

$$\text{Number of links } L = \frac{180^\circ}{\tan^{-1}\left(\frac{P}{D+2S}\right)} = \frac{180^\circ}{\tan^{-1}\left(\frac{50.8}{2920}\right)} = 180.6 \cdots \cdots 182 \text{ links}$$

[Conclusion] Chain: RS160 K1 attachments on every 2nd link with 182 links Sprocket: RS160 pin gear specialized sprocket 14T (PCD231.78 mm) or larger, S35C steel, teeth induction hardened.

(Cautions)

- ① Ambient conditions during applications are not taken into consideration. When the ambient conditions are not adequate, the selection needs to be made in consideration of the conditions.
- ② Refer to Section 10.2 on page 182 for cautions regarding pin gears.

11. Temperature Selection Method

11.1 RS Roller Chain temperature selection method

This selection method is for sizes that may experience strength degradation from temperature. Additionally, lubrication should be carried out using a suitable lubricant according to the operating temperatures.

- | | |
|--|---|
| <p>1) Problems with roller chain transmission at high temperatures</p> <ul style="list-style-type: none"> ● Increased wear due to hardness reduction ● Increased elongation due to softening ● Poor articulation and increased wear due to oil degradation and carburization ● Increased wear and poor articulation due to scaling | <p>2) Problems with roller chain transmission at low temperatures</p> <ul style="list-style-type: none"> ● Reduction of impact strength due to low temperature brittleness ● Solidification of lubricant ● Poor articulation due to frost and ice adhesion |
|--|---|

Table 7 Maximum allowable load of RS Roller Chain at high and low temperatures

Temperature	RS roller chain		RS Cold Resistant Chain *
	RS60 or under	RS80 or over	
Below - 60°C	-	-	Unusable
- 60°C - - 50°C	-	-	Catalog Value × 1/2
- 50°C - - 40°C	-	Unusable	∕ × 2/3
- 40°C - - 30°C	Unusable	Catalog Value × 1/4	Catalog Value
- 30°C - - 20°C	Catalog Value × 1/4	∕ × 1/3	∕
- 20°C - - 10°C	∕ × 1/3	∕ × 1/2	∕
- 10°C - - 60°C	Catalog Value	Catalog Value	∕
60°C - 150°C	Catalog Value	Catalog Value	Unusable
150°C - 200°C	∕ × 3/4	∕ × 3/4	-
200°C - 250°C	∕ × 1/2	∕ × 1/2	-
Over 250°C	Unusable	Unusable	-

Note)

1. * RS Cold Resistant Chain
 - Made to order
 - Select using allowable load selection method
2. The ambient temperature is different from the temperature of the roller chain itself.

11.2 Lambda Chain KF Series Lube Free Drive Chain Selection

Use the kilowatt ratings chart based selection method for selecting lube free drive chains.

$$\text{Corrected kW} < \text{kW ratings} = \text{Catalog kW ratings} \times \text{Temperature coefficient}$$

Note: The chain is usable if the kilowatt ratings are greater than the corrected kW.

Multiply the ambient temperature the chain will be used in by the temperature coefficient in Table 2 below to calculate kilowatt ratings. Calculate the temperature coefficient with the maximum usage temperature of the equipment on which the chain will be installed.

Table 2: Temperature Coefficient by Ambient Temperature

Temperature	RS40 – RS80
Room temperature – 150°C	Catalog kW rating × 1
150°C – 200°C	Catalog kW rating × 3/4
200°C – 230°C	Catalog kW rating × 1/2

Note: A double-strand LMC chain only has the maximum allowable load of a single-strand LMD chain. Always confirm strength when using for power transmission.

11.3 Selection method for Stainless Steel Roller Chain (SS and NS series) at high temperatures (400°C or higher)

As the temperature of a chain increases, its strength decreases. The usage limit at high temperatures is determined by the temperature of the chain itself. Contact a Tsubaki representative when using stainless steel chain at ambient temperatures of 400°C or higher. However, chain cannot be used at 700°C or higher. When a chain is selected using the temperature selection method, the chain speed must be below the maximum speed of the allowable load selection method.

Changes and cautions associated with high temperature environments are:

- 1) All clearances need to be adjusted to prevent poor articulation and poor roller rotation due to thermal expansion.
- 2) The chain may break (creep rupture) under low loads as the temperature increases.

12. Special selection method for Corrosion Resistant Roller Chain

When selecting Corrosion Resistant Chain use the allowable load selection method.

- 1) The maximum allowable tension for Corrosion Resistant Chain is low compared to Standard RS Roller Chain (excluding NEP).
- 2) Avoid using offset links when possible.
- 3) Refer to the following page when acid or alkali solutions or chemicals will come in direct contact with the chain.
- 4) Selection formula:

$$\text{Maximum working load applied to the chain} \times \text{Service factor } K_s \times \text{RPM } K_n \times \text{Number of teeth factor } K_z \leq \text{Maximum allowable load of the chain}$$

Roller Chain Selection

13. Corrosion resistance guide for Corrosion Resistant Chains and Sprockets

Corrosion resistance varies accordingly depending on application conditions. This table should not be considered as a guarantee. Using this chart as a reference, be sure to check the corrosion resistance of the chain in advance according to the actual operating conditions determining chain type.

- : Sufficient corrosion resistance
- △ : Corrosion resistance in some applications
- × : No corrosion resistance
- : Unknown

Chemical / Food product	Corrosion-Resistant Drive Chain								Sprocket	
	SS	LSC	AS	NS	TI	PC	PC-SY	Engineering plastic	SS	
Acetic acid 10% 20°C	○	○	○	○	○	○	○	△	○	
Acetone 20°C	○	○	○	○	○	○	×	○	○	
Alcohol (Methyl, ethyl, propyl, and butyl)	○	○	○	○	○	○	○	○	○	
Aluminum sulfate Saturated 20°C	○	○	×	○	○	-	-	-	○	
Ammonia water 20°C	○	○	○	○	○	○	○	○	○	
Ammonium chloride 50% Boiling point	△	△	×	○	○	-	-	-	△	
Ammonium nitrate Saturated boiling	○	○	○	○	○	△	○	○	○	
Ammonium sulfate " 20°C	○	○	△	○	○	-	-	-	○	
Beer 20°C	○	○	○	○	○	○	○	○	○	
Benzene 20°C	○	○	○	○	○	○	○	○	○	
Boric acid 50% 100°C	○	-	○	○	○	-	-	-	○	
Butyric acid 20°C	○	-	○	○	○	○	-	○	○	
Calcium chloride " 20°C	△	-	×	○	○	△	○	○	△	
Calcium hydroxide 20% Boiling	○	-	○	○	○	○	-	○	○	
Calcium hypochlorite (Bleaching powder) Available chlorine 11~14% 20°C	○	-	×	○	○	×	○	△	○	
Carbolic acid 20°C	○	-	○	○	○	×	○	×	○	
Carbon tetrachloride (Dry) 20°C	○	○	○	○	○	○	○	○	○	
Carbonated water	○	○	○	○	○	-	-	-	○	
Chlorine gas (Dry) 20°C	△	-	×	△	○	-	○	×	△	
Chlorine gas (Wet) 20°C	×	×	×	△	○	-	○	×	×	
Chlorine water	×	×	×	○	○	×	-	×	×	
Chromium acid 5% 20°C	○	○	△	○	○	×	○	×	○	
Citric acid 50% 20°C	○	○	○	○	○	-	○	○	○	
Coffee Boiling	○	○	○	○	○	○	○	○	○	
Cola syrup	○	○	○	○	○	○	○	○	○	
Concentrated nitric acid 65% 20°C	○	×	×	○	○	×	○	×	○	
" " Boiled	△	×	×	△	○	×	×	×	△	
Creosote 20°C	○	-	○	○	○	-	-	-	○	
Developing solution (Photo) 20°C	○	-	△	○	○	○	○	○	○	
Ether (Ethyl ether) 20°C	○	○	○	○	○	○	○	○	○	
Ferric chloride 5% 20°C	△	△	×	△	○	-	-	×	△	
Formalin (Formaldehyde) 40% 20°C	○	○	○	○	○	-	-	△	○	
Formic acid 50% 20°C	○	×	○	○	○	×	○	×	○	
Fruit juice 20°C	○	○	△	○	○	○	○	○	○	
Gasoline 20°C	○	○	○	○	○	○	○	○	○	
Glycerine 20°C	○	○	○	○	○	○	○	○	○	
Honey, syrup	○	○	○	○	○	○	○	○	○	
Hydrochloric acid 2% 20°C	×	×	×	×	○	×	○	×	×	
Hydrogen peroxide 30% 20°C	○	-	△	○	○	×	○	×	○	
Hydrogen sulfide (Dry)	○	-	○	○	○	○	○	○	○	
" (Moistened)	×	×	×	×	○	×	-	-	×	
Kerosene 20°C	○	○	○	○	○	-	○	-	○	
Ketchup 20°C	○	○	○	○	○	○	○	○	○	
Lactic acid 10% 20°C	○	○	△	○	○	-	○	○	○	
Lard	○	-	○	○	○	-	-	-	○	
Linseed oil 100% 20°C	○	-	△	○	○	-	○	○	○	

Chemical / Food product	Corrosion-Resistant Drive Chain								Sprocket	
	SS	LSC	AS	NS	TI	PC	PC-SY	Engineering plastic	SS	
Malic acid 50% 50°C	○	○	○	○	○	○	○	○	○	
Mayonnaise 20°C	○	○	△	○	○	○	○	○	○	
Milk 20°C	○	○	○	○	○	○	○	○	○	
Nitric acid 5% 20°C	○	-	△	○	○	×	○	×	○	
Oil (Plant and mineral) 20°C	○	○	○	○	○	○	○	○	○	
Oleic acid 20°C	○	○	○	○	○	-	○	○	○	
Oxalic acid 10% 20°C	○	○	△	○	○	-	○	○	○	
Paraffin 20°C	○	○	○	○	○	○	○	○	○	
Petroleum 20°C	○	-	○	○	○	-	○	○	○	
Phosphoric acid 5% 20°C	○	-	△	○	○	×	○	×	○	
" 10% 20°C	△	×	△	△	○	×	○	×	△	
Picric acid Saturated 20°C	○	-	○	○	○	-	-	-	○	
Potassium chloride Saturated 20°C	○	○	△	○	○	-	-	-	○	
Potassium dichromate 10% 20°C	○	○	○	○	○	-	-	-	○	
Potassium hydroxide 20% 20°C	○	×	○	○	○	○	○	○	○	
Potassium nitrate 25% 20°C	○	○	○	○	○	-	-	-	○	
" 25% Boiling point	○	-	×	○	○	-	-	-	○	
Potassium permanganate Saturated 20°C	○	○	○	○	○	-	-	-	○	
Seawater 20°C	△	△	×	○	○	△	○	○	△	
Soapy water 20°C	○	○	○	○	○	○	○	○	○	
Sodium carbonate Saturated boiling point	○	○	○	○	○	-	-	-	○	
Sodium chloride " 20°C	○	○	△	○	○	○	○	○	○	
Sodium cyanide 20°C	○	○	-	○	○	-	-	-	○	
Sodium hydrogen carbonate 20°C	○	○	○	○	○	-	-	-	○	
Sodium hydroxide 25% 20°C	○	×	○	○	○	○	○	○	○	
Sodium hypochlorite 10% 20°C	×	×	×	○	○	×	○	△	×	
Sodium perchlorate 10% Boiling point	○	-	×	○	○	-	-	-	○	
Sodium sulfate Saturated 20°C	○	○	○	○	○	-	-	-	○	
Sodium thiosulfate 25% Boiling point	○	○	○	○	○	-	-	-	○	
Soft drink 20°C	○	○	○	○	○	○	○	○	○	
Stearic acid 100% Boiling point	×	×	×	○	○	×	-	○	×	
Sugar solution 20°C	○	○	○	○	○	○	○	○	○	
Sulfur Dioxide (Wet) 20°C	○	-	×	○	○	-	-	-	○	
Sulfuric acid 5% 20°C	×	×	×	○	○	×	○	×	×	
Synthetic detergent	○	○	○	○	○	○	○	○	○	
Tartaric acid 10% 20°C	○	○	○	○	○	○	○	○	○	
Turpentine oil 35°C	○	-	○	○	○	-	-	-	○	
Varnish	○	-	○	○	○	-	-	-	○	
Vegetable juice 20°C	○	○	○	○	○	○	○	○	○	
Vinegar 20°C	△	-	×	○	○	△	○	△	△	
Water	○	○	○	○	○	○	○	○	○	
Whiskey 20°C	○	○	○	○	○	○	○	○	○	
Wine 20°C	○	○	○	○	○	○	○	○	○	
Zinc chloride 50% 20°C	△	△	×	△	○	△	○	×	△	
Zinc sulfate 25% Saturated 20°C	○	○	○	○	○	-	○	-	○	

Handling Roller Chains and Sprockets

1. How to Cut Roller Chain

If the chain you purchased is either a unit length (3,048 mm) or on a reel, it is necessary for you to cut the chain to the necessary length.

How to cut a roller chain — Using a chain vise and punch
 — Using a chain breaker

1.1 Using a chain vise and punch

- 1) For riveted type roller chain, grind down one end of the outer plate's two pins (same side) to the surface of the plate. Be careful of the chain overheating during the grinding process. This process is unnecessary for Poly Steel Chain as there are no rivets. As RS08B-1 to RS16B-1 use easy cutting pins, the rivets do not need to be ground.
- 2) Remove the cotter pin for cotter pin type roller chain.

(Grind the rivets of the pins until they are flush with the plate.)

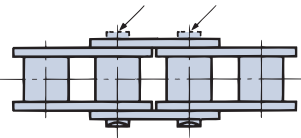

Fig. 1 Rivet-type roller chain

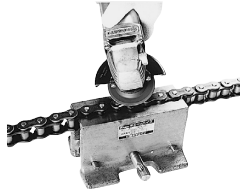

Fig. 2 Grinding the pin ends

- 3) Place the roller chain into the groove of the chain vise (see Accessories Section) and tighten the vise to secure the roller to be disassembled.
 - ① Follow 1.3 and 1.4 for Poly Steel Chain and Lambda chain.
 - ② For multi-strand Super Roller Chain, place the lowest roller into the groove of the chain vise.

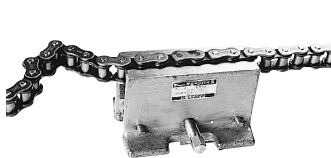
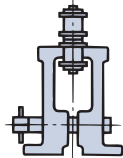

Fig. 3 Setting the roller chain in the chain vise



Setting Super Roller Chain

- 4) Place a primary punch (see Accessories Section), according to chain size, on the head of the ground pin, and then hit the head of the primary punch with a hammer. Make sure to hit the pins alternatively to ensure the pins are removed evenly and at the same time. Continue to tap the pin until just before the pin is removed from the outer plate.

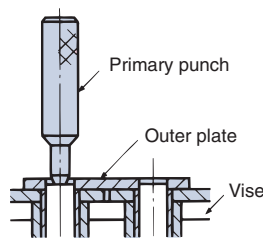

Fig. 4 Tapping the pin with the primary punch

- 5) Use a secondary punch (see Accessories Section) to remove the pin completely from the outer link plate. Check to make sure that the bush where the pin was removed has not come loose or deformed. Do not use if loose or deformed.

⚠ Safety precautions

- ① Make sure to use a grinder when grinding the riveted portion of one end of the rivet-type pin. If it is extracted without being ground first, more time and effort will be spent, and will damage the chain.
- ② Do not reuse any removed parts.

1.2 Using a chain breaker

- 1) For riveted type roller chain, grind down one end of the outer plate's two pins (same side) to the surface of the link plate. (Same as 1.1) Remove the cotter pin for cotter pin type roller chain.
- 2) Remove the two pins from the same outer plate. Check to make sure that the bush where the pin was removed has not come loose or deformed. Do not use if loose or deformed.

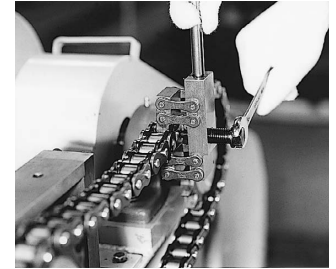

Fig. 5 How to cut a chain using a chain screw

⚠ Safety precautions

- ① A chain breaker (see Accessories Section) is a tool made for cutting chain, and can cut roller chain that is set on a machine. In this case, it is necessary beforehand to support the load on the roller chain and the weight of the roller chain itself to prevent it from falling after being cut.
- ② Do not reuse any removed parts.

1.3 How to cut Poly Steel Chain

- 1) Support the outer plate of the chain in the cradle and push down on the pinhead with the exclusive punch. Then lightly hit the head of the punch using a hammer.
- 2) Avoid using excess force on the engineering plastic part, as there is a possibility of causing damage.

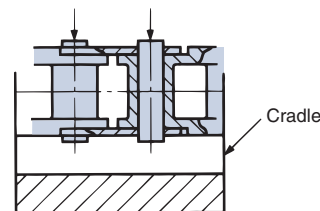

Fig. 6 Poly Steel Chain set in a cradle

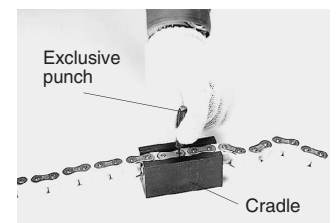

Fig. 7 Cutting Poly Steel Chain

Handling Roller Chains and Sprockets

1. 1 How to cut Lambda Chain

- 1) Support the chain with a chain vise and grind down one end of the outer link plate's two pins (same side) to the surface of the link plate. Be careful of the chain overheating during the grinding process. Grinding should be carried out slowly so as not to overheat the bushes in particular.
- 2) Then cut the chain using an exclusive cradle (see Accessories section) and an RS Roller Chain punch. Important points for cutting are outlined in 4) and 5) in 1.1. However, use an exclusive cradle instead of a vise.
- 3) Hit the pins alternatively when removing the pins with a punch. Take extra care not to remove or cause any damage to the bush. Do not use bush if it has come loose or been damaged.

2. How to Connect Roller Chain

2. 1 When connecting chain on sprocket teeth

When connecting or disconnecting roller chain, it is convenient to use the sprocket teeth. Please carry out the following steps.

- 1) Wind the chain around one of the sprockets so that both ends of the chain are facing each other on the sprocket.
- 2) Insert the connecting link in the two end links of the chain.
- 3) Insert the connecting link plate of the connecting link and fasten the plate using the clips/cotter pins or spring pins provided.
- 4) When using a press-fit connecting link or F-Type (semi press-fit) connecting link, insert the connecting link plate by tapping it with a hammer until it moves into position.

Then fasten it using the clips/cotter pins or spring pins provided.

- 5) When using the sprocket teeth to connect the chain, take care not to damage the teeth, particularly when using a cast iron sprocket.

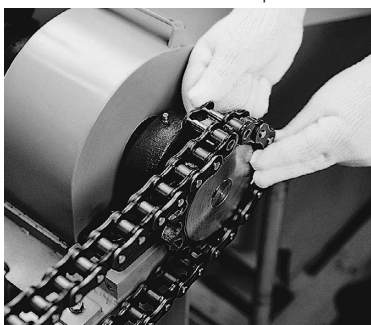

Fig. 8 Connecting on a sprocket

2. 2 When connecting between shafts

If a sprocket cannot be used due to layout, follow the procedures below.

- 1) Wind the chain around the sprockets and pull the chain ends together using a chain puller (see Accessories section) or wire.
- 2) Insert the connecting link in the two end links of the chain.
- 3) Insert the connecting link plate of the connecting link and fasten the plate using the clips/cotter pins or spring pins provided.



Fig. 9 Connecting between shafts

2. 3 Clip and Cotter Pins

1) Clip

Clips are used for small size roller chain (under RS60) connecting links. When connecting the chain, the clip should be inserted securely into the slot of the pin on the connecting link after the connecting plate has been inserted on the pin. If the legs of the clips are spread too far they will not catch properly and will fall off during operation of the chain, causing accidents. Care should be taken when inserting them. The clip is generally installed opposite to the direction of travel for the chain as shown in Fig. 10.

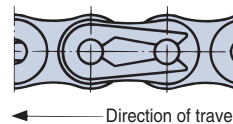
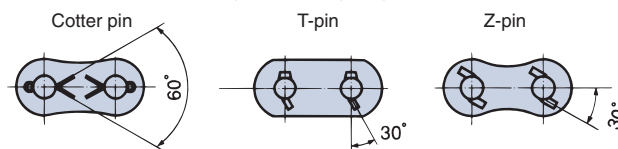

Fig. 10 Direction in which the clip is installed

2) Cotter Pins

Tsubaki cotter pins are heat treated for Standard, Heavy-Duty, and Lambda Chain. The legs of the cotter pin should be bent approx. 60 degrees. Cotter pins should not be reused, and commercially available cotter pins other than those produced by Tsubaki should be avoided.

Fig. 11 Opening range of pins



RS Roller Chain cotter pin dimensions (These pins are not available commercially.)

Chain size	Nominal cotter pin dimension	Chain size	Nominal cotter pin dimension
RS35	1 × 6	RS100	2.5 × 20
RS40	1 × 6	RS120	3 × 23
RS50	1.6 × 8	RS140 · RS160	4 × 24.5
RS60	2 × 10	RS180	5 × 32
RS80	2.5 × 14	RS200	5 × 37

Note: RS240 uses a roll pin.

⚠ Safety Precautions

- ① Avoid using offset links wherever possible by varying the center distance between shafts or using an idler.
- ② In the case of pins and connecting link plate holes being press-fit type with F-Type or other connecting links, please avoid widening the connecting link plate hole or narrowing the pin diameter to make connecting easier, as this will result in a reduction in roller chain strength and cause an accident.
- ③ The outer link of cotter pin type roller chain can be used as a substitute for the connecting link. However, due to the press fit connection, the outer link plate must be carefully driven onto the pin parallel to the connecting link. If the connecting link plate is installed without due care to parallelism, chain damage or increased wear may result. Use caution as per (2) above.
- ④ Do not reuse press fit type link plates that have been detached, as the detachment results in a reduction in strength.

3. Roller Chain Lubrication

Lubrication is very important in roller chain transmission, and becomes especially important when stringent demands are placed on chain performance.

When lubrication is not complete, even the most advanced transmission device will not realize its full service life. Under some conditions the device may wear out within a very short period of time. For this reason, exercise special care with respect to lubrication.

- 1) The main reason for oiling and lubing roller chain is to minimize wear elongation of the chain and prevent corrosion. Wear elongation is caused by wear between the pin and bush in articulating parts.
- 2) Roller chain is coated with oil before being packaged (except for stainless steel chain). This oil is a high grade oil that prevents rust and provides lubrication. The oil prevents the wear that frequently occurs in the initial stage of operation, and it works well with lubrication oil to maintain a high wear resistance.
- 3) Avoid wiping the oil coating off of delivered roller chain, and avoid washing the chain with detergent or other cleaning agents.

3.1 Oil application locations

- 1) Roller chain wear occurs from wear between each pin and bush, and thus oil must be applied to these parts.
- 2) On the slack part of the chain, apply lubrication oil to the gap between each outer plate and inner plate. At the same time, apply oil between the bushes and rollers.

3.3 Recommended lubricating oils

1) SAE numbers (Table 1)

Lubricant type Ambient temperature	A I · A II · B				C			
	-10°C to 0°C	0°C to 40°C	40°C to 50°C	50°C to 60°C	-10°C to 0°C	0°C to 40°C	40°C to 50°C	50°C to 60°C
Chain number								
RS50 or lower small pitch chain	SAE10W	SAE20	SAE30	SAE40	SAE10W	SAE20	SAE30	SAE40
RS60 / 80	SAE20	SAE30	SAE40	SAE50				
RS100					SAE20	SAE30	SAE40	SAE50
RS120 or higher large pitch chain	SAE30	SAE40	SAE50					

2) Commercially available lubrication (Table 2)

Manufacturer names are shown in no particular order

ISOVG (cSt@40°C)	SAE	SAE10W	SAE20	SAE30	SAE40	SAE50
		32	68	100	150	220
Manufacturer name						
Idemitsu Kosan		Daphne Mechanic Oil 32	∕ 68	∕ 100	∕ 150	∕ 220
Exxon Mobile		DTE Oil Light	∕ Heavy Medium	∕ Heavy	∕ Extra Heavy	∕ BB
Showa Shell Sekiyu		Terasu Oil C32	∕ 68	∕ 100	∕ 150	∕ 220
JX Nippon Oil & Energy		Super Mulpus DX32	∕ 68	∕ 100	∕ 150	∕ 220
		FBK Oil RO32	∕ 68	∕ 100	∕ 150	∕ 220

3) Examples of lubrication at low and high temperatures (Table 3)

The following oils are available when roller chain is used at low or high temperatures. Regarding other brands, use an equivalent.

Ambient and operating temperature	-50°C to -25°C	-25°C to 0°C	-10°C to 60°C	60°C to 200°C	150°C to 250°C
Manufacturer name Lubrication name	Toray Dow Corning SH510 Shin-Etsu Chemical KF50 GE Toshiba Silicon TSF431	Exxon Mobile Artic Oil C baby	See above	Sato Special Oil Co. Hot Bearing Oil #255 Exxon Mobile DTE Oil HH Matsuken Moresukohai Lube L-150	Sato Special Oil Co. High Thermal Lube #700

Lubrication methods are drip, manual, and brush.

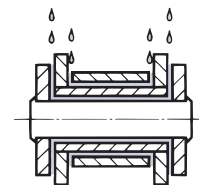

Fig. 10 Oiling locations

3.2 Chain used for lifting

- 1) In general the chain has no catenary parts. If possible, remove the load that acts on the roller chain before lubing the chain.
- 2) For roller chain that does not articulate, oil the chain sufficiently and then apply a thick layer of grease around the roller chain to prevent corrosion. Sufficiently lube end fitting connections, even if these do not move.
- 3) For roller chain that is used outdoors, contact with rain and snow will remove the lubrication and cause harmful corrosion, and thus a cover or other protection should be installed. If rain or snow does fall on the chain, remove the moisture and then promptly lube the chain and coat it with a thick layer of grease.

Handling Roller Chains and Sprockets

3.4 Lubrication systems and methods (Table 4)

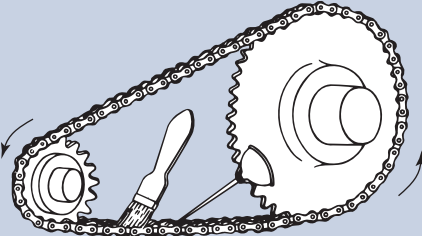
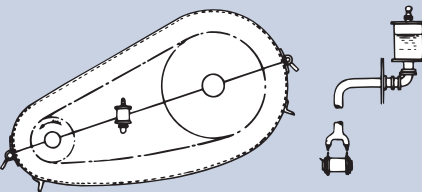
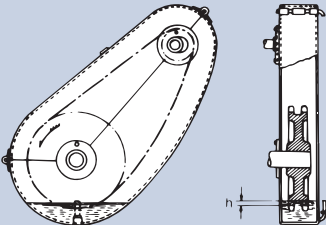
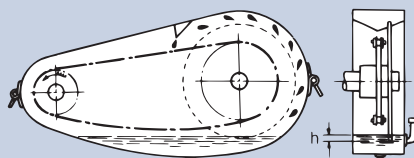
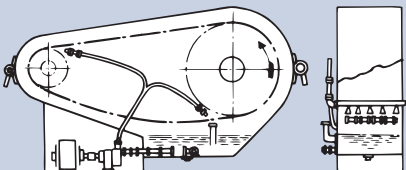
Lubrication system	Method	Quantity																																		
A	 <p>Apply oil to the gaps in the pins and inner links on the slack side of the chain. A brush can also be used.</p> <p>⚠ Stop operation before oiling.</p>	Oil with sufficient frequency (in general about once every 8 hours) so that the roller chain bearings do not dry out.																																		
	<p>Drip Lubrication</p>  <p>Using a simple case, this method drips oil supplied from an oil cup.</p>	For one strand of chain, drip about 5 to 20 drops of oil each minute. Drip more oil on higher speed chains.																																		
B	<p>Oil Bath</p>  <p>The chain is run through oil in a leak-free casing.</p>	If depth h from the surface of the oil to the lowest point the chain reaches is too deep, the oil may heat up (80°C or higher) and deteriorate. The depth to which the chain descends in the oil should be about 6 to 12 mm.																																		
	<p>Lubrication using a Slinger Disc</p>  <p>Use a slinger disc attached to a leak free case to splash oil on the chain. The peripheral velocity of the disc should be 200 m/min or higher.</p> <p>If the width of the chain is greater than 125 mm, attach discs to both sides.</p>	The lowest point h reached by the slinger disc should be about 12 to 25 mm below the surface of the oil. The roller chain should not enter the oil.																																		
C	<p>Forced Lubrication</p>  <p>The oil is circulated in a leak-free case and cooled by a pump. When there are n strands of chain, $n+1$ oiling holes are required, targeting the gaps between each part.</p>	<p>Approximate oiling quantity per oiling hole (L/min)</p> <table border="1"> <thead> <tr> <th rowspan="2">Name</th> <th rowspan="2">Chain number Chain speed (m/min)</th> <th colspan="4">Chain number</th> </tr> <tr> <th>RS60 or smaller</th> <th># 80 # 100</th> <th># 120 # 140</th> <th>#160 or larger</th> </tr> </thead> <tbody> <tr> <td>RS</td> <td>500 – 800</td> <td rowspan="2">1.0</td> <td rowspan="2">1.5</td> <td rowspan="2">2.5</td> <td rowspan="2">4.0</td> </tr> <tr> <td>SUP</td> <td>Less than 300</td> </tr> <tr> <td>RS</td> <td>800 – 1,100</td> <td rowspan="2">2.0</td> <td rowspan="2">2.5</td> <td rowspan="2">3.5</td> <td rowspan="2">5.0</td> </tr> <tr> <td>SUP</td> <td>300 – 500</td> </tr> <tr> <td>RS</td> <td>1,100 – 1,400</td> <td rowspan="2">3.0</td> <td rowspan="2">3.5</td> <td rowspan="2">4.5</td> <td rowspan="2">6.0</td> </tr> <tr> <td>SUP</td> <td>500 or more</td> </tr> </tbody> </table>	Name	Chain number Chain speed (m/min)	Chain number				RS60 or smaller	# 80 # 100	# 120 # 140	#160 or larger	RS	500 – 800	1.0	1.5	2.5	4.0	SUP	Less than 300	RS	800 – 1,100	2.0	2.5	3.5	5.0	SUP	300 – 500	RS	1,100 – 1,400	3.0	3.5	4.5	6.0	SUP	500 or more
Name	Chain number Chain speed (m/min)	Chain number																																		
		RS60 or smaller	# 80 # 100	# 120 # 140	#160 or larger																															
RS	500 – 800	1.0	1.5	2.5	4.0																															
SUP	Less than 300																																			
RS	800 – 1,100	2.0	2.5	3.5	5.0																															
SUP	300 – 500																																			
RS	1,100 – 1,400	3.0	3.5	4.5	6.0																															
SUP	500 or more																																			

To verify sufficient lubrication is taking place, remove the chain and inspect the connecting pins and bushes. If the contact surfaces of the pins or bushes show tearing or a red or dark brown color, lubrication is generally not sufficient.

4. Layout and Installation of Roller Chain

4.1 Speed ratio and chain lap

A roller chain transmission speed ratio up to 7:1 is normally suitable; however, at very slow speeds a ratio up to about 10:1 is possible. The chain lap between the small sprocket and chain must be 120° or more. For lifting applications, the angle must be 90° or more.

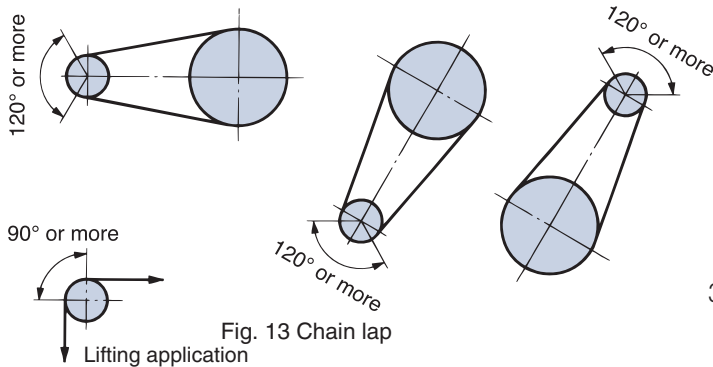

Fig. 13 Chain lap

4.2 Distance between shafts

The minimum distance can be as short as desired as long as the teeth of the two sprockets are not in contact. The optimum center-to-center distance between the shafts is 30 to 50 times the pitch of the roller chain. However, if the load is variable, a distance of 20 times or less is suitable.

4.3 Amount of slack

1) Unlike V or flat-belt transmission, there is no need to apply an initial tension in roller chain transmission; roller chain is normally used with a suitable amount of slack. If too much tension is applied to roller chain, the oil film between the pins and bushes will break, causing increased wear and damage on the roller chain and bearings. If there is too much slack in the roller chain, the chain will vibrate and ride up the sprocket, damaging both chain and sprocket.

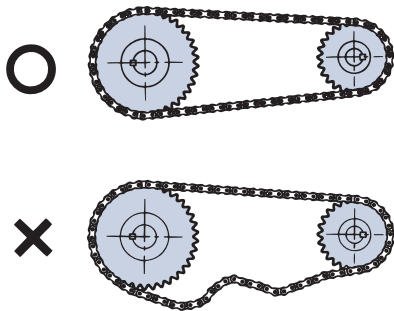

2) If possible, the lower side should be the slack side in roller chain transmission. The amount of slack is appropriate when the distance (SS') that the chain can be moved perpendicularly by hand at the center of the slack side is 4% of the span (AB). (For example, when the span is 800 mm, the amount of slack should be $800 \text{ mm} \times 0.04 = 32 \text{ mm}$.)

In the following situations, this should be 2%:

- 1) When the transmission is vertical or close to vertical (a tensioner is required).
- 2) When the distance between the shafts is more than 1 m.
- 3) When frequent starts are made with a heavy load.
- 4) When sudden reverse motion takes place.

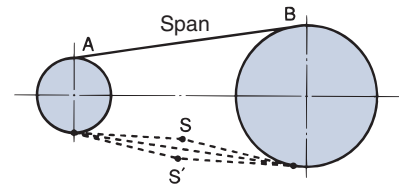

Fig. 14 Amount of slack

- 3) Roller chain will stretch slightly during the first few dozen hours of use as the contact surfaces wear in (about 0.05%). This may result in too much slack in the roller chain and may require adjustment of the slack. A tensioner can be used if the layout is designed for it. If you do not have a tensioner, move the shafts to adjust the amount of slack. Once the chain is worn in, very little stretching will occur.

4.4 Horizon precision and parallelism of the shafts

The installation precision of the sprocket has a large effect on the smoothness of roller chain transmission. It also affects roller chain life.

Install the sprockets correctly as described below.

- 1) Verify Horizontal precision with a level. Adjust the precision to within $\pm 1/300$.

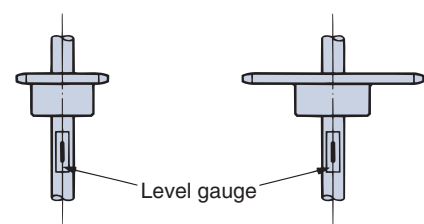

Fig. 15 Horizontal precision

- 2) Use a scale to correct the degree of parallelism of the shafts. Adjust the shafts so that they are parallel to within $\pm 1/300 = (A-B)/L$.

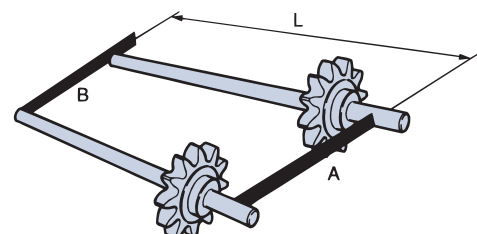

Fig. 16 Degree of parallelism of the shafts

Handling Roller Chains and Sprockets

3) Using a straightedge (or a scale), adjust the two sprockets so that they are parallel. Adjust to within the following values based on the distance between the shafts.

- Up to 1 m : ± 1 mm
- 1 m to 10m : ± $\frac{\text{Distance between shafts(mm)}}{10,000}$
- 10m or more : ± 10 mm

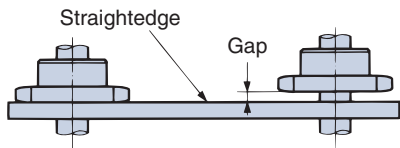

Fig. 17 Sprocket misalignment

4) Secure each sprocket to the shaft with a power lock, lock sprocket, or key (if needed use a collar, set bolt, etc.).

4.5 Layout (⚙ indicates the driver side in the illustrations)

1) General layout

Ideally, the line connecting the sprocket centers in the roller chain transmission equipment should be close to level. In a layout that is close to vertical, the roller chain may stretch and fall off the sprocket. Thus, an idler or tensioner should be used. If possible keep the angle of inclination within 60°.

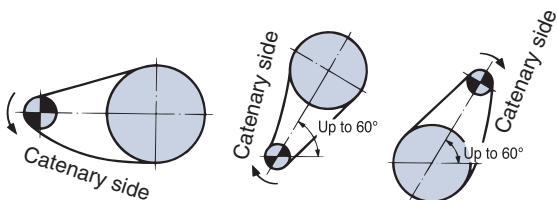

Fig. 18 General layout

2) Layouts requiring caution

(1) When the slack is on the upper side

When the center-to-center distance between the shafts is short, move the shafts to adjust the distance and slightly increase the tension.

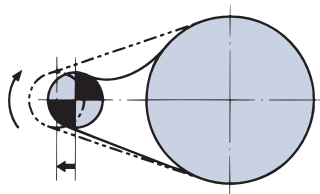

Fig. 19 Layout when the center-to-center distance is short

When the center-to-center distance is long, insert an intermediate idler under the slack part to support the roller chain.

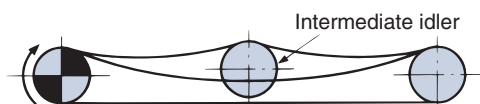

Fig. 20 Layout when the center-to-center distance is long

(2) When the chain speed is fast and the load varies Roller chain may vibrate if the natural vibration frequency of the chain, shock frequency of the driven machine, or chordal action of the chain (vertical pulsation of the chain due to the polygon effect) synchronize. In this event, use a guide shoe (made of NBR or ultra-high polymer polyethylene) or other device to stop the vibration.

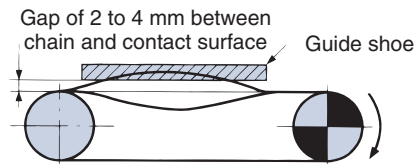

Fig. 21 Guide shoe to prevent vibration

(3) When the centerline is vertical Install a tensioner that can automatically eliminate excess slack. This is particularly necessary when the drive shaft is on the bottom.

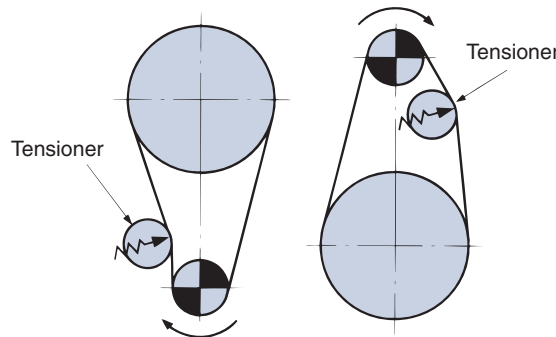
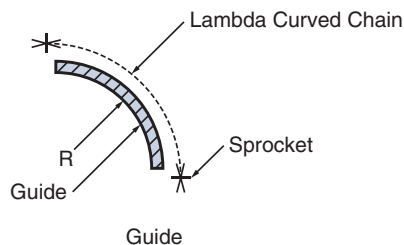

Fig. 22 Vertical transmission

4.6 Lambda Curved Chain installation

1) Installing the guide

Compared to a standard chain, a Lambda Curved Chain has a larger gutter between the pins and bushes, providing a greater degree of freedom. For this type of chain, please install a guide on the chain so that it engages straight onto the sprocket.



2) Minimum lateral bending radius (r)

Please manufacture the guide so that its minimum lateral bending radius is equal to or greater than the specifications shown below.

	Minimum lateral bending radius (r)
RS40-LMC-CU-I	400
RS50-LMC-CU-I	500
RS60-LMC-CU-I	600

5. Sprockets

5.1 Hardening the teeth

When a sprocket is used under the following conditions, the sprocket teeth must be hardened.

- 1) When there is a small number of teeth (24 or less), and the speed is 1/8 or higher of the maximum rotation speed indicated on the kilowatt ratings tables.
- 2) When using small sprockets with a speed ratio of greater than 4:1.
- 3) When a large load is used at low speed (when using the Low-Speed Selection Method).
- 4) When using under conditions that will cause the teeth to wear.

5.2 Number of teeth

As many teeth as possible should be used on the sprocket on the high-speed shaft side to help ensure smooth drive transmission. Generally, 15 or more teeth should be used. However, when the speed ratio is high and the number of teeth on the low-speed sprocket exceeds 120, chain engagement problems can occur when there is even slight chain wear. In this case, decrease the number of teeth on the high-speed sprocket, but the number of teeth should still be kept to 13 or higher. However, if the sprocket will be used at extremely low speed and not subjected to shock, a sprocket with 12 or fewer teeth can be used.

5.3 Precautions related to additional processing

1) Shaft bore processing

① Maximum shaft bore processing dimensions

The maximum finished shaft bore size should be at or below the size shown in the specifications for each model number. Please contact a Tsubaki representative if using standards other than the JIS standards key.

② Finishing standards

When finishing, verify the standards for the tooth outer diameter ("D_o" in the diagram) and the hub outer diameter ("D_H" in the diagram).

Also, verify that the deflection on the tooth root ("a" in the diagram) and the deflection on the end surface of the tooth ("b" in the diagram) are at or below the values shown below.

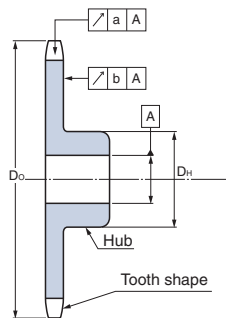

When using machine specifications

Diameter of tooth root cylinder	90 or less	> 90 but ≤ 190	> 190 but ≤ 850	> 850 but ≤ 1180	Greater than 1180
Deflection at tooth root a	0.15	0.0008d _r +0.08			0.76
Face runout	0.25		0.0009d _r +0.08		1.14

2) Sprocket welding

When welding a hub to Type A sprockets for use, the welding can cause deformation or deflection of the tooth and surface, making it impossible to maintain product quality. As such, welding should be avoided. With Type A Strong Series sprockets, welding can also decrease the hardness of the sprockets, so again, welding should be avoided.

3) Processing on the hub outer diameter

Do not perform any additional processing to the outer diameter of the hub. If processing needs to be performed, please first contact a Tsubaki representative.

New JIS key (Table 5)

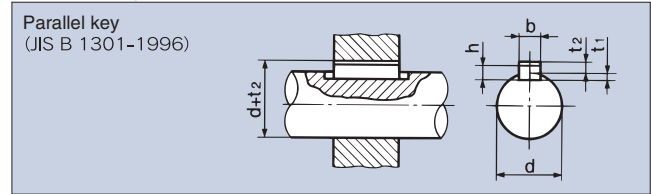

Shaft bore diameter d	Designated key diameter Shaft × Height b × h	Keyway depth	
		Shaft t ₁	Boss d+t ₂
6 — 8	2×2	1.2	d+ 1.0
8 ∕ 10	3×3	1.8	d+ 1.4
10 ∕ 12	4×4	2.5	d+ 1.8
12 ∕ 17	5×5	3.0	d+ 2.3
17 ∕ 22	6×6	3.5	d+ 2.8
20 ∕ 25	(7×7)	4.0	d+ 3.0
22 ∕ 30	8×7	4.0	d+ 3.3
30 ∕ 38	10×8	5.0	d+ 3.3
38 ∕ 44	12×8	5.0	d+ 3.3
44 ∕ 50	14×9	5.5	d+ 3.8
50 ∕ 55	(15×10)	5.0	d+ 5.0
50 ∕ 58	16×10	6.0	d+ 4.3
58 ∕ 65	18×11	7.0	d+ 4.4
65 ∕ 75	20×12	7.5	d+ 4.9
75 ∕ 85	22×14	9.0	d+ 5.4
80 ∕ 90	(24×16)	8.0	d+ 8.0
85 ∕ 95	25×14	9.0	d+ 5.4
95 ∕ 110	28×16	10.0	d+ 6.4
110 ∕ 130	32×18	11.0	d+ 7.4
125 ∕ 140	(35×22)	11.0	d+11.0
130 ∕ 150	36×20	12.0	d+ 8.4
140 ∕ 160	(38×24)	12.0	d+12.0
150 ∕ 170	40×22	13.0	d+ 9.4
160 ∕ 180	(42×26)	13.0	d+13.0
170 ∕ 200	45×25	15.0	d+10.4
200 ∕ 230	50×28	17.0	d+11.4
230 ∕ 260	56×32	20.0	d+12.4
260 ∕ 290	63×32	20.0	d+12.4
290 ∕ 330	70×36	22.0	d+14.4
330 ∕ 380	80×40	25.0	d+15.4
380 ∕ 440	90×45	28.0	d+17.4
440 ∕ 500	100×50	31.0	d+19.5

Note: The nominal dimensions shown in parentheses are not defined in international standards.

Old JIS key (Table 6)

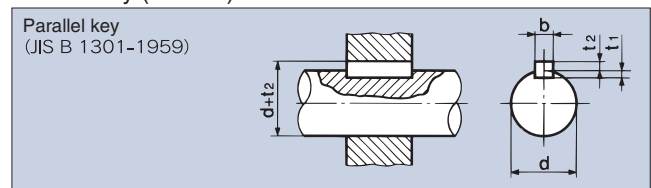

Shaft bore diameter d	Designated key diameter Shaft × Height b × (t ₂ × t ₁)	Keyway depth		
		Shaft t ₁	Boss d+t ₂	
10 or higher	13 Greater than	4×4	2.5	d+ 1.5
13 or lower	20 ∕	5×5	3.0	d+ 2.0
20 ∕	30 ∕	7×7	4.0	d+ 3.0
30 ∕	40 ∕	10×8	4.5	d+ 3.5
40 ∕	50 ∕	12×8	4.5	d+ 3.5
50 ∕	60 ∕	15×10	5	d+ 5
60 ∕	70 ∕	18×12	6	d+ 6
70 ∕	80 ∕	20×13	7	d+ 6
80 ∕	95 ∕	24×16	8	d+ 8
95 ∕	110 ∕	28×18	9	d+ 9
110 ∕	125 ∕	32×20	10	d+10
125 ∕	140 ∕	35×22	11	d+11
140 ∕	160 ∕	38×24	12	d+12
160 ∕	180 ∕	42×26	13	d+13
180 ∕	200 ∕	45×28	14	d+14
200 ∕	224 ∕	50×31.5	16	d+15.5
224 ∕	250 ∕	56×35.5	18	d+17.5

Handling Roller Chains and Sprockets

6. Chain Test Run

After installing the chain, carry out a test run and check the following items before you actually start running the chain.

6.1 Pre-test Run

- 1) Connecting link plates, clips, and cotter pins are installed correctly.
- 2) Chain slack has been properly adjusted.
- 3) Adequate lubrication is available.
- 4) The chain is not touching the chain case.
- 5) The roller chain path is clean and free from obstructions.

6.2 Test Run

- 1) There should be no strange noises. Make sure the chain does not touch the case.
- 2) Look for excessive chain vibration.
- 3) Make sure the chain does not run up on the sprockets.
- 4) Ensure that the chain is not jammed into the sprockets.
- 5) The chain should articulate smoothly.

Check the inspection checklist if there are any problems, and ensure roller chain and sprocket are correctly installed.

7. Roller Chain Inspection

- 1) In general, roller chain life is said to be reached when parts are damaged or when 1.5% wear elongation occurs. See 6) in 7.3. Try to replace the chain before these conditions occur.
- 2) If roller chain selection and operating conditions are suitable, you can expect rather long life with no unexpected trouble from the chain. However, wear will progress between the pins and bushes after long periods. The following should be noted and inspected.

7.1 Inspection Checklist (Table 7)

Procedures	Method	Inspection items	Reference page for details
Step I	Visually check the chain during operation and look for any abnormalities.	<ol style="list-style-type: none"> 1. There should be no strange noises. 2. Look for excessive chain vibration. 3. Make sure the chain does not run up on the sprockets. 4. The chain is not jammed into the sprockets. 5. There are no stiff areas during articulation. 6. Adequate lubrication is available (lubricating system and quantity of oil). 7. Make sure the chain doesn't touch the case. 	Inspection points are on the following pages and on the troubleshooting pages.
Step II	Stop the chain and carefully inspect each part of the chain and sprocket.	<ol style="list-style-type: none"> 1. Check the external cleanliness, corrosion, and lubrication conditions; also, look for scratches or other damage to the plate side and edge surfaces, pin edges, and roller surfaces. 2. Inspect for pin rotation and inspect the clearance between plates and pins. 3. Inspect the sprocket teeth surfaces and teeth side surfaces for scratches or marks. 4. Measure the wear elongation of the chain. 5. Check the articulation of the chain and rotation of the rollers. 6. When using an end fitting for lifting applications, inspect the wear of the end bolts and the wear of the connecting plate pins. Also, check for proper installation at the same time. 	
Step III	In order to investigate in more detail, remove the roller chain and inspect it visually or check it with measuring instruments.	<ol style="list-style-type: none"> 1. The inspection items are identical to those in Step II except in more detail. 	

7.2 Inspection intervals

Regular inspection of roller chain is recommended at one month intervals. Inspection should be carried out at shorter intervals in:

- 1) Special or corrosive environments.
- 2) High speeds with sudden stoppage.
- 3) Lifting or indexing operations.

7.3 Inspection requirements for ordinary transmission

1) Inspection lubrication conditions

- ① During operation, check to see if there is lubrication in the clearance between the outer plate and inner plate. Also, check if the chain or rotating disc is immersed in lubricating oil.
- ② When the chain is stationary, the chain surface will generally appear dirty from wear dust if lubrication is unsatisfactory. This is especially the case between the link plates.
- ③ When the chain is removed, connecting link pins and the edge of the inside of the bushes should be checked. If there are any scratches, or red or reddish-brown coloration, lubrication is improper or insufficient.

2) Inspecting link plates

- ① If repeat loads over the maximum allowable load are put on the chain, there is a strong possibility of fatigue breakage of the link plates. It is difficult to notice initial cracking from fatigue breakage simply from external observation.
- ② Usually, a crack develops at the edge of a hole or at the side of the link plate, as shown in the illustrations below. The presence of cracks should be checked carefully. Fatigue breakage progresses little by little, so it can be noticed with close attention.

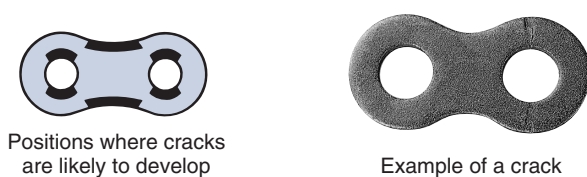

Fig. 23 Cracks on the link plates

- ③ When wear occurs from sliding between the edges of the plates and the guides, it is necessary to adjust the position of either the chain or the guides. The allowable wear on the link plates is limited to 5% of their height.



Fig. 24 Wear on the edges of the link plates

3) Inspecting Pins

When the pins rotate, the roller chain must be completely replaced with new chain. This also applies to the connecting pins. By removing the connecting parts it is possible to see the conditions of wear and rust on the surfaces of the pins.

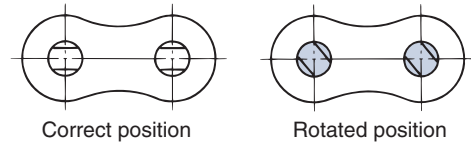

Fig. 25 Rotation of the pins

4) Inspecting rollers

- ① As with the link plates, if rollers are also subjected to loads over the maximum allowable load, the repeated impact load between the chain and the sprockets may cause fatigue breakage to occur. The roller should be checked in the same way as the link plate.
- ② If foreign objects interfere with the engagement of the roller and sprocket, the roller may be damaged and a crack may develop. Careful attention should be paid to the above. Furthermore, with high-speed operations, even if foreign objects do not interfere with engagement, cracks may appear from the impact with the sprocket teeth.

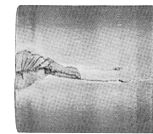

Fig. 26 Cracks on the rollers

- ③ Chains damaged by fatigue breakage from the rollers must be completely replaced, as each part has received the same amount of repeated load.
- ④ Also check for poor roller rotation.

5) Inspecting sprockets

- ① Chain and sprocket engagement can be checked by observing the roller and teeth surface. Proper engagement is when the contact area is uniform with point A in the illustration. If the contact area is lopsided or the sides of the teeth are wearing away (point B), this may have been caused from improper installation of the sprockets or twisting of the roller chain. In this case, rechecking/readjustment is necessary.
- ② The normal point of impact is slightly up from the tooth root. However, when initial tension is applied to the chain and tension remains on the slack side, the roller will slightly touch the tooth root. However, point A receives the strongest impact.

Handling Roller Chains and Sprockets

- ③ When idlers or tensioners are used, the contact area will be the center of the tooth root.

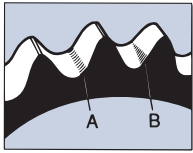

B: Improper installation

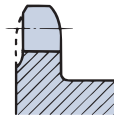

Improper installation causes the surface of the teeth to become ground down

Fig. 27 Contact area of the sprocket teeth

- ④ When wear on the teeth reaches the values in the following table, the lifespan of the sprocket has been reached. For a sprocket with induction hardened teeth, the lifespan is reached when the hardened layer has been removed.

Limit of usage based on tooth thickness/Dimension B (Table 8)

Size of RS Roller Chain	Dimension B		Size of BS Roller Chain	Dimension B Normal
	Normal	Pin-Gear		
RS 11-SS-1	0.6	—	RF06B-1	1.6
∅ 15-1	1.1	—	RS08B-1	2.1
∅ 25-1	1.5	—	∅ 10B-1	2.9
∅ 35-1	2.5	—	∅ 12B-1	3.6
∅ 41-1	2.6	—	∅ 16B-1	5.0
∅ 40-1	2.5	3.1	∅ 20B-1	6.8
∅ 50-1	2.9	3.6	∅ 24B-1	7.2
∅ 60-1	3.7	4.6	∅ 28B-1	8.6
∅ 80-1	5.0	6.3	∅ 32B-1	11.9
∅ 100-1	6.9	8.6	∅ 40B-1	12.7
∅ 120-1	8.7	10.9		
∅ 140-1	10.6	13.3		
∅ 160-1	12.4	15.5		
∅ 180-1	11.3	14.1		
∅ 200-1	12.6	15.8		
∅ 240-1	15.1	18.9		
RF320-T-1	19.9	24.9		
RF400-T-1	24.9	31.2		

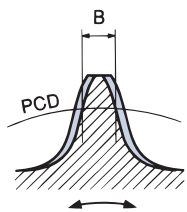

Forward and reverse

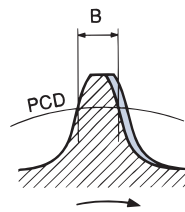

One direction

- ⑤ If a new roller chain is run on a worn sprocket, the chain will wear at a faster rate than normal. In this case, when replacing the chain, replacement of the sprocket is also recommended.

6) Inspection of chain elongation

- ① Chain elongation is caused not by deformation of the link plate, but by wear on the pin and bush. Therefore, the remaining chain life can be estimated by periodically measuring the chain elongation.

② Measuring chain elongation

- The chain should be measured whilst stretching it slightly to eliminate any slack.
- Measure the distance of the inside (L1) and outside (L2) of the rollers at both ends of the measured links using a vernier caliper to get measurement (L).

$$L = \frac{L_1 + L_2}{2}$$

- (3) When measuring, use at least 6 to 10 links to help keep any measuring error down to a minimum.

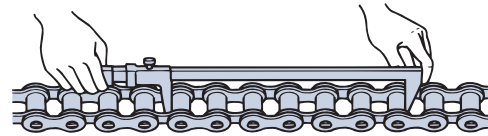

Positioning of vernier calipers for measuring 6 links

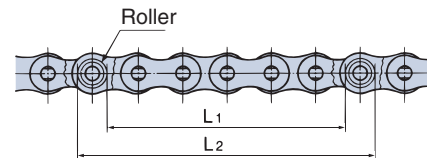

Fig. 28 Measuring length

(4) Finding chain elongation

$$\text{Chain elongation (\%)} = \frac{\text{Measured length} - \text{Standard length}}{\text{Standard length}} \times 100$$

$$\text{Standard length} = \text{Chain pitch} \times \text{Number of links}$$

- For multi-strand roller chain, the measurement is carried out in the same way as for single strand roller chain of the same pitch.
- The limit of usage based on roller chain elongation for a smooth transmission is as follows.

Limit of usage based on elongation (table 9)

Large sprocket with up to 60 teeth	Chain elongation 1.5%
Large sprocket with between 61 - 80 teeth	Chain elongation 1.2%
Large sprocket with between 81 - 100 teeth	Chain elongation 1.0%
Large sprocket with between 101 - 110 teeth	Chain elongation 0.8%

- (7) Dimensions for evaluating standard length (chain pitch x number of links) and 1.5% elongation are shown in Table 10 below.
- (8) When the length of the roller chain cannot be measured with calipers, a tape measure may be used; however, measurements need to be taken over as many links as possible to reduce measuring error.
- (9) When chain elongation of Lambda/X-Lambda Roller Chain reaches about 0.5% it may be losing its lubricating properties. This may be determined by the adhesion of red wear particles between the plates and the occurrence of articulation stiffness. When this occurs, the life of the chain has been reached.

- 4) Inspect for twisting and side bending of the roller chain. If partial twisting or side bending of the chain occurs, the complete roller chain should be replaced. (Fig. 29)

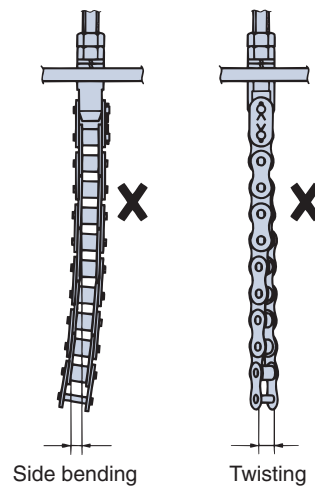

Fig. 29 Twisting of the roller chain

Standard Length and 1.5% Elongation (Table 10)

Chain No.		RS25	RS35	RS41	RS40
6 links measured	Standard length	38.10	57.15	76.20	76.20
	1.5% elongation	38.67	58.01	77.34	77.34
10 links measured	Standard length	63.50	95.25	127.00	127.00
	1.5% elongation	64.45	96.68	128.91	128.91

Chain No.		RS50	RS60	RS80	RS100
6 links measured	Standard length	95.25	114.30	152.40	190.50
	1.5% elongation	96.68	116.01	154.69	193.36
10 links measured	Standard length	158.75	190.50	254.00	317.50
	1.5% elongation	161.13	193.36	257.81	322.26

Chain No.		RS120	RS140	RS160	RS180
6 links measured	Standard length	228.60	266.70	304.80	342.90
	1.5% elongation	232.03	270.70	309.37	348.04
10 links measured	Standard length	381.00	444.50	508.00	571.50
	1.5% elongation	386.72	451.17	515.62	580.07

Chain No.		RS200	RS240
6 links measured	Standard length	381.00	457.20
	1.5% elongation	386.72	464.06
10 links measured	Standard length	635.00	762.00
	1.5% elongation	644.53	773.43

- 5) End fittings

Check for damage by deformation of the hole due to wear. If the hole is damaged or deformed, replace the end bracket immediately. The clearance on the pinhole of the bracket affects the life of the roller chain and should be kept to a minimum

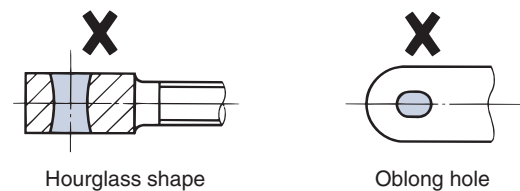

Fig. 30 Wear on the end fitting hole

7.4 Inspection of lifting and shuttle traction

- 1) This should be carried out with the same requirements as for ordinary transmission shown in item 6.3.
- 2) It is important to check the lubrication of the connecting parts between the roller chain and end brackets where end brackets are installed, as well as the parts where the roller chain winds around the sprocket. (Refer to item 3.2 on page 192.)
- 3) The parts where the roller chain bends around the sprocket should be checked when inspecting the wear elongation of the roller chain.

7.5 Storage

Avoid storing spare parts, such as roller chains, sprockets, and end brackets, in high temperature/high humidity and dusty environments. Also, when storing roller chain that has been removed, wash the roller chain and then apply lubrication. After the roller chain clearances have been supplied with a sufficient amount of lubricant, wrap the chain in grease paper completely before storing away.

Handling Roller Chains and Sprockets

8. Cautions on Use in Special Environments

As a general rule, roller chain should be used in a clean air flow; however, when used in special atmospheres, refer to the various items that follow.

8.1 Use in wet conditions

If the chain is used in a sterilizing machine or water screen, for example, where the chain is splashed with water or goes through heated vapor, the following problems may occur.

- 1) An increase in wear elongation due to improper or insufficient lubrication.
- 2) Decrease in fatigue strength from rust and corrosion (pitting) of the chain.
 - 1) Countermeasures
 - (1) Reduce bearing pressure by using a larger sized chain to improve wear resistance.
 - (2) Use corrosion resistant roller chain for rust prevention.

8.2 Use in acidic or alkaline conditions

If roller chain is exposed to acidic or alkaline conditions, such as battery acid and liquid used in plating processes, the following problems may occur.

- 1) Embrittlement fracture of link plates and pins.
- 2) Fatigue breakage of link plates and pins due to rust and pitting corrosion.
- 3) Wear from usual mechanical wear and corrosion.
- 4) Reduction in volume of the whole chain from corrosion.
- 5) In special cases where the chain is underwater (immersed in liquid), electrochemical corrosion may occur.
- 6) There are also circumstances where even stainless steel roller chain will corrode. Fig. 31 shows an example of chain that was used in a plating apparatus. The chain fell to pieces within one month due to the effects of the acid.
 - 1) Countermeasures for embrittlement fractures (Stress corrosion cracking)
 - Adopt a brittleness countermeasure that lowers crack susceptibility.
 - Install a cover or casing to prevent acids or alkalis from contacting the chain.
 - Adopt a high-grade material with anti-corrosive properties.
 - 2) Countermeasures for corrosion
 - Use surface-treated chain.
 - Install a cover or casing to prevent acids or alkalis from contacting the chain.
 - Adopt a high-grade material with anti-corrosive properties.

In general, embrittlement fractures (stress corrosion cracking) occur around link plate holes. This is the area where the pin and bush are press-fitted to the link plate, and with the highest concentration of stress. Cracks are generated even when there is no tension on the chain. Roller chain in general is more susceptible to acids than alkalis, and in special cases, embrittlement fractures (stress corrosion cracking) are generated by seawater or pit water.

8.3 Use under conditions where wear is a problem

If the chain is exposed to highly abrasive materials that promote wear such as sand, coke, and metal particles, the following problems may occur:

- 1) When abrasive materials penetrate between the pins and bushes, chain wear is promoted and poor articulation occurs.
- 2) When abrasive materials penetrate between the bushes and rollers, chain wear is promoted and poor roller rotation occurs.
- 3) When the abrasive materials penetrate between the link plates, poor articulation occurs.
 - 1) Countermeasures
 - Install a protective casing against dust.
 - Remove foreign particles by regularly washing the roller chain.
 - Reduce bearing pressure by using a larger sized chain to improve wear resistance.
 - Increase wear resistance by applying special processing to the parts of the chain where wear is a problem.



Fig. 31 Corrosion of stainless steel roller chain

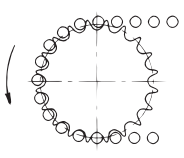
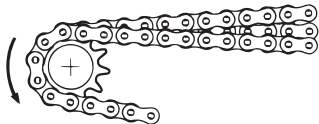
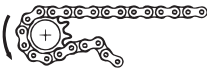

Fig. 32 Hydrogen embrittlement cracking

9. Roller Chain Drive Troubleshooting and Problem Solving

When there is significant damage and breakage to the roller chain and sprockets, please carry out the following remedies and replace with new chain and sprockets as necessary.

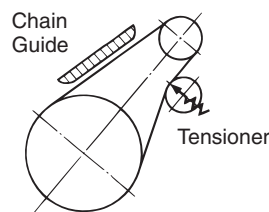

9.1 General

Symptom	Possible Causes	Remedy
 <p>Chain is riding up on the sprocket.</p>	The roller chain and sprocket do not match.	Replace the chain or sprocket with the correct size.
	Excessive load.	Decrease the load, or increase the number of strands or size of the chain.
	Elongation of the chain due to wear or excessively worn sprocket teeth.	Replace with new chain and sprockets.
Unusual noises.	Improper installation of the sprocket or shaft.	Inspect and correct.
	Chain casing or bearings are loose.	Tighten all bolts and nuts.
	Excessive or insufficient slack in the chain.	Adjust the distance between shafts to obtain the proper amount of slack.
	Excessively worn chain or sprocket.	Replace the chain and sprocket with new chain and sprocket.
	Lack of or unsuitable lubrication.	Provide proper lubrication according to the operating conditions.
 <p>Excessive vibrations in chain.</p>	Chain is resonating with periodic external force.	Change the chain's mode of vibration. <ol style="list-style-type: none"> 1. Preventing resonance. <ol style="list-style-type: none"> a. Change the natural frequency of the chain. <ul style="list-style-type: none"> • Alter the effective tension either by applying an initial tension or adjusting the existing one. • Install a tensioner to change the chain span. • Replace the chain. Choose a different quality and spring coefficient. b. Change the vibration frequency. <ul style="list-style-type: none"> • Change the speed of rotation of the sprocket. • Re-evaluate the device set-up. 2. Mechanically reducing the vibrations. <ul style="list-style-type: none"> • Install a guide shoe. • Install a self-adjusting tensioner on the slack side.
	Load fluctuations are excessively large.	Reduce fluctuations with a fluid coupling or similar technique.
 <p>The chain winds onto the sprocket. (Poor separation from the sprocket teeth)</p>	Span between shafts is too large.	Install an idler.
	Excessive slack in chain.	Adjust the chain length or distance between shafts. Install a tensioner.
	Elongation of the chain due to chain wear or excessively worn sprocket teeth.	Replace with new chain and sprocket.

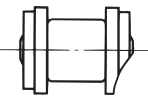

Handling Roller Chains and Sprockets

Before Use
 Standard Roller Chains
 Lube-Free Roller Chains
 Heavy Duty Roller Chains
 Corrosion Resistant Roller Chains
 Specialty Roller Chains
 Sprockets
 Pin Gear Drives
 Accessories
 Selection

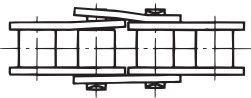
Symptom	Possible Causes	Remedy
Rusting of the chain.	Improper lubrication or poor environment.	Replace chain and protect it from the environment with chain casing or proper lubrication.
Excessive wear on the inside surface of the link plates and sides of the sprocket teeth.	Improper installation. 	Correct sprocket and shaft installation.
Excessive wear on the link plate side surfaces and pin heads.	Improper installation of guides, etc. 	Check the condition of the guides, and increase the gap between the guides and the chain.
 Improper flex or bending of chain, tight joints.	Chain is not installed correctly.	Inspect the installation and correct as necessary.
	Contamination from metal dust or dirt because of improper lubrication.	Remove the chain, wash it thoroughly, and provide proper lubrication.
	Excessive load or bent pin.	Reduce the load or increase the number of or size of chains. Replace chain with a larger size.
	Corrosion or rusting.	Install a chain casing to protect the chain.
	Seizing from improper lubrication.	Provide proper lubrication according to the operating conditions.
	Seizing of pin and bush. 	Provide the proper operating conditions.
Pin and bush seized from high-speed operation. This causes improper bending and can lead to chain breakage.		
Spreading of link plates.	Uneven or excessive loading caused by improper installation. 	Replace with new chain and correct installation.

9.2 Link Plate Related

Symptom	Possible Causes	Remedy
Breakage of link plate.	Excessively large shock load.	Reduce shock loads by making the start-up, stopping, and other actions smoother (installing a shock absorber, etc.). Increase the size or number of chains.
	Vibration in the chain.	Install an anti-vibration device (for example, a tensioner or idler), Refer to "Excessive vibration in chain" page.
	Large inertia in the driven machine. (excessive load).	Increase the size of number of chains.
	Corrosion.	Replace with a new chain. Install a casing to protect the chain. Otherwise, periodically clean the chain.



① Static fracture

Stretching the link plate with a tensile load beyond its breaking load will cause it to stretch and then break.





② Fatigue fracture

By repeatedly applying a load past its fatigue limit (fatigue strength), the fatigue will start at holes and then suddenly break.



③ Offset link plate fatigue

Offset link plates are bent at the center, and the resulting concentration of stress at the bend can cause a fatigue break. Avoid using offset links in high-stress applications.

Cracks in the link plates (fatigue), which are perpendicular to the direction of pull.	Loads are greater than allowable.	Remove all large or excessively repeating loads. Otherwise, increase the size or number of chains. Replace with a new chain.
Deformation of link plate holes. 	Excessive load.	Remove the cause of the excessive load. Replace with a new chain.
Corrosion stress cracks appear, usually as bow-shaped cracks in the link plate. 	The chain is being used in an acidic or alkaline environment. (This is not caused by a repetitive load).	<ul style="list-style-type: none"> Replace with a new chain. Install a casing to protect the chain from the environment. Consider a chain with a high resistance to corrosion stress cracks. (Please contact a Tsubaki representative.)

Handling Roller Chains and Sprockets

9.3 Pin Related

Symptom	Possible Causes	Remedy
Breakage of pin.	Excessively large shock loads.	Reduce shock loads by making the start-up, stopping, and other actions smoother.
	Subject to a repetitive load greater than the fatigue limit of the pin.	Remove the large repetitive load. Otherwise, increase the size or number of chains.
	Corrosion.	Install a casing to protect the chain. Periodically clean and lubricate the chains.

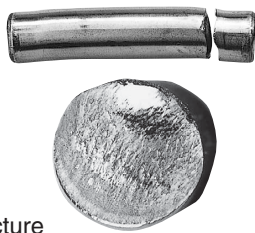

① Static fracture

The type of fracture found when subjecting the chain to the breakage test. Occurs when chain is subjected to a load greater than its breakage strength.



② Fatigue fracture

Occurs when the pin is repetitively subjected to loads greater than its fatigue limit. Re-check the size of the peak load and formulate a countermeasure.



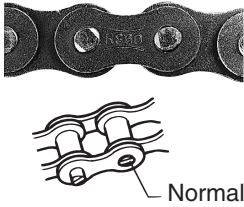

③ Shock-induced bending fracture

The pin is subjected to a large shock load and breaks. The side with the initiating point receives tensile load, and the fracture progresses from this point. A pin is especially susceptible to becoming weak with regard to bending when the surface of the pin has corroded. This type of phenomenon occurs quite easily.

Pin rotates or begins to stick out.	Excessive load or improper lubrication.	Replace with new chain. Improve the lubrication or loading conditions.
	Operating a chain at high load without proper lubrication can create friction between the pin and bush, causing the pin to rotate. In this condition, the pin may come out, leading to chain breakage.	Replace with new chain immediately. Do not weld or reuse the pins. (Dispose of the old chain to be sure that it is not used again by mistake.) Also, if the pin head or link plate surface is worn, check the installation.
Wear or rust occurs only at the connecting pin in a lifting application or similar operation.	Improper initial lubrication at installation.	Replace the connecting link. If pin wear is excessive, replace the chain also. Take special care to properly install the connecting section for devices such as end brackets used for lifting applications, etc.

9.4 Bush / Roller Related

Symptom	Possible Causes	Remedy
Roller and/or bush splits. (Falls off)	Excessive load or speed of rotation.	Choose a different chain according to the kW ratings table.
	Inadequate lubrication.	Replace the chain. Provide adequate lubrication according to the operating conditions.
Roller does not rotate.	 Fatigue fracture. Reached the point of fatigue during operation and eventually broke. Impact with the sprocket teeth at a force exceeding the chain's transmission capacity.	
	RS11-SS-1, RS15-1, RS25-1, RS35-1	A bushed chain and not a roller chain is being used.
	The inner link plate is moving inward, or the bush is cracked.	Replace with a new chain. Re-inspect the installation and load conditions.
Roller is opening up.	Foreign particles have gotten between the bush and roller.	Periodically clean the chain. Install a casing to protect the chain.
	Excessive load. 	Reduce the load. Provide adequate lubrication.
Roller is becoming hourglass shaped.	Excessive load or inadequate lubrication.	Replace with new chain. Improve the lubrication or loading conditions.

For Safe Use



WARNING

Obey the following points in order to prevent hazardous situations.

- Do not use chains and accessories (accessories and parts) for anything other than their original purpose.
- Never perform additional processing on the chain.
 - Do not anneal the various parts of the chain.
 - Do not clean the chain with either acid or alkali, as they may cause cracking.
 - Do not electroplate the chain or its parts, as it may cause cracking due to hydrogen embrittlement.
 - Do not weld the chain, as the heat may cause cracking or a reduction in strength.
 - When heating or cutting the chain with a torch, remove the links immediately adjacent and do not use them again.
- When there is need to replace a lost or damaged portion of a chain, always replace the whole chain with a new product rather than replacing only the lost or damaged portion.
- When using a chain on suspension equipment, establish a safety perimeter and strictly prevent entry to the area directly below the suspended object.
- Always employ hazard protection devices for the chain and sprocket (safety cover, etc.).
- If a substance that can cause embrittlement cracking (acid, strong alkali, battery fluid, etc.) adheres to the chain, stop using the chain immediately and replace it with a new one.
- During installation, removal, maintenance inspection and lubrication of the chain:
 - Perform the operation according to the instruction manual or this catalog.
 - Always turn off the power switch to the device and make sure that it cannot be turned on accidentally.
 - Anchor the chain and parts so that they cannot move freely.
 - Perform cutting and connecting procedures properly using a press or other special tool.
 - Wear clothing and employ protective devices that are appropriate to the job (safety glasses, gloves, safety shoes, etc.).
 - Only allow experienced personnel to perform chain replacement procedures.
- A fail safe back up system is suggested whenever using Leaf Chain to safely support the load in the event of a chain failure.



CAUTION

Obey the following points in order to prevent accidents.

- Only handle the chain after thoroughly understanding its structure and specifications.
- When installing a chain, inspect it in advance to confirm that it has not been damaged in transport.
- Be sure to perform regular maintenance inspections on the chain and sprocket.
- Chain strength varies according to manufacturer. When selecting a chain based on a Tsubaki catalog, always use the corresponding Tsubaki product.
- Minimum tensile strength refers to the failure point when the corresponding load is applied to the chain once and does not refer to the allowable operational load.

Warranty

1. Products manufactured by Seller: (a) conform to the design and specifications, if any, expressly agreed to in writing by Seller; and (b) are free of defects in workmanship and materials at the time of shipment. The warranties set forth in the preceding sentence are exclusive of all other warranties, express or implied, and extend only to Buyer and to no other person. ALL WARRANTIES OF MERCHANTABILITY OR FITNESS FOR A PARTICULAR PURPOSE ARE HEREBY EXCLUDED.

NON-RELIANCE

2. Buyer is not relying upon any advice, representations or warranties (except the warranties expressly set forth above) of Seller, or upon Seller's skill or judgment regarding the Seller's products.
Buyer is solely responsible for the design and specifications of the products, including without limitation, the determination of suitability for Buyer's application of the products.

CLAIMS

3. (a) Any claim relating to quantity or type shall be made to Seller in writing within 7 days after receipt of the products; any such claim made thereafter shall be barred.
(b) Any claim under the above-stated Limited Warranty shall be made to Seller in writing within three (3) months after receipt of the products; any such claim made thereafter shall be barred.
(c) Seller's liability for breach of warranty or otherwise is limited to repair or replacement, at Seller's option, of non-conforming or defective products. Buyer waives all other remedies, including, but not limited to, all rights to consequential, special or

incidental damages, including, but not limited to, damages resulting from personal injury, death or damage to or loss of use of property.

(d) Repair, alteration, neglect or misuse of the products shall void all applicable warranties.

INDEMNIFICATION

4. Buyer will indemnify, defend and hold Seller harmless from all loss, liability, damage and expense, including attorneys' fees, arising out of any claim (a) for infringement of any patent, trademark, copyright, misappropriation of trade secrets, unfair competition or similar charge by any products supplied by Seller in accordance with the design or specifications furnished by Buyer, or (b) arising out of or connected with the products or any items into which the products are incorporated, including, but not limited to, any claim for product liability (whether or not based on negligence or strict liability of Seller), breach of warranty, breach of contract or otherwise.

ENTIRE AGREEMENT

5. These terms and conditions constitute the entire agreement between Buyer and Seller and supersede any inconsistent terms and conditions, whether contained in Buyer's purchase order or otherwise, and whether made heretofore or hereafter.
No statement or writing subsequent to the date hereof which purports to modify or add to the terms and conditions hereof shall be binding unless consented to in writing, which makes specific reference hereto, and which has been signed by the party against which enforcement thereof is sought. Seller reserves the right to change these terms and conditions without prior notice.